



EUROPEAN SOUTHERN OBSERVATORY

TECHNICAL REPORT

No. 14

MARCH 1984

TECHNICAL PHOTOGRAPHY AT ESO SKY ATLAS LABORATORY

BY

R. M. WEST
L. DIEBOLD
B. DUMOULIN
C. MADSEN
J. QUÉBATTE
E. VÖLK
H. ZODET

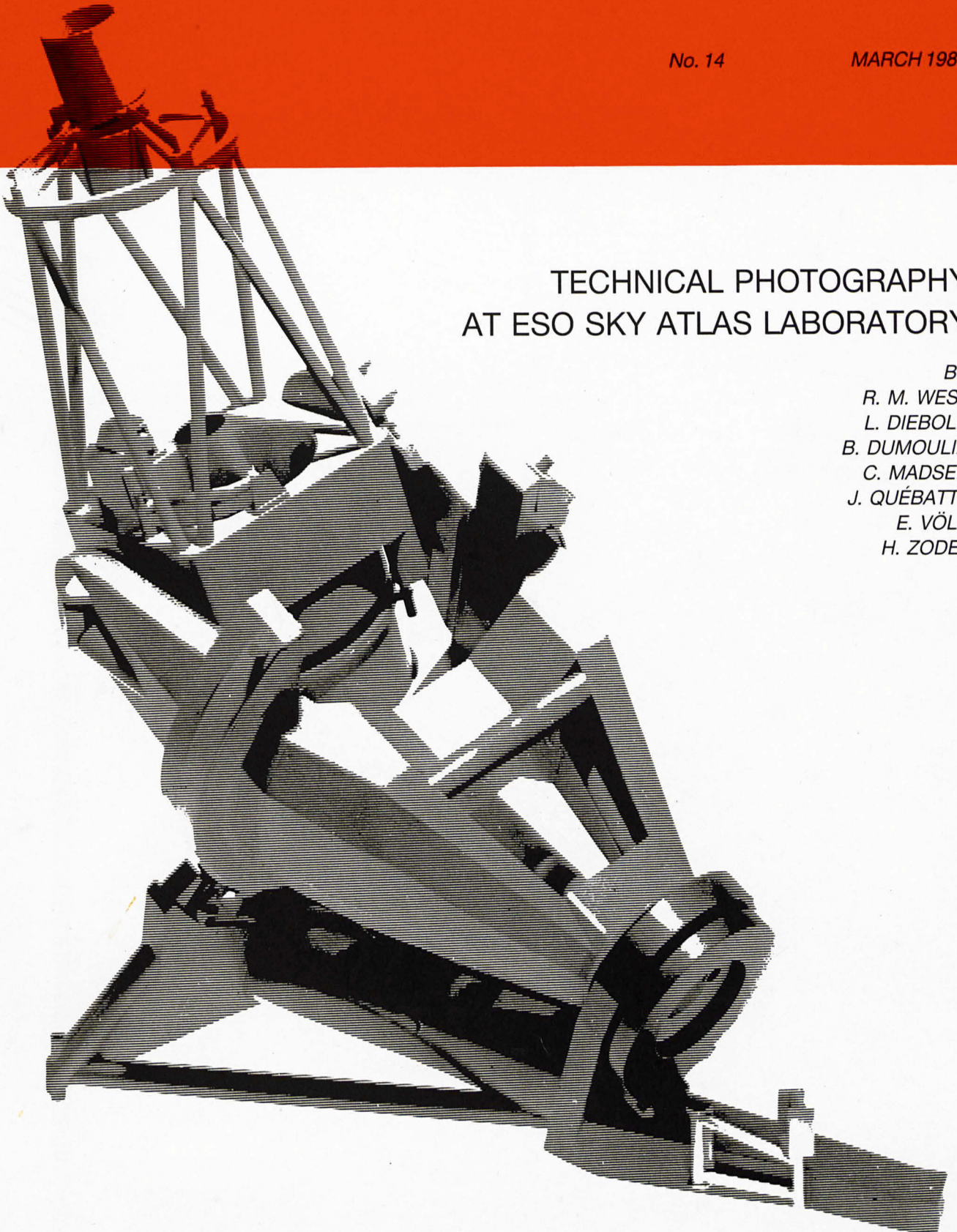

This report is published by the
European Southern Observatory
D-8046 Garching bei München
Federal Republic of Germany

The European Southern Observatory (ESO) is the result of a
scientific collaboration for astronomical research in the
Southern Hemisphere between the eight member countries, Belgium,
Denmark, Federal Republic of Germany, France, Italy, Netherlands
Sweden and Switzerland.

Copyright ESO 1984

Technical Photography

at

ESO SKY ATLAS LABORATORY

R.M. West

L. Diebold

B. Dumoulin

C. Madsen

J. Québatte

E. Völk

H. Zodet

EUROPEAN SOUTHERN OBSERVATORY

Karl-Schwarzschild-Straße 2

D-8046 Garching bei München

Federal Republic of Germany

The ESO Sky Atlas Laboratory

(SAL)

Contents:

1.	Introduction.....	1
2.	Laboratory Layout.....	3
3.	Photographic Plate Service.....	11
4.	Atlas Copying On-glass.....	13
4.1	Equipment.....	13
4.2	Copying Techniques for Glass Plates.....	18
4.2.1	Plate Cleaning.....	19
4.2.2	Vacuum.....	20
4.2.3	Plate Processing.....	20
5.	Atlas Copying On-film.....	23
5.1	Equipment.....	23
5.1	Procedures.....	26
6.	Quality Control and Sensitometry.....	28
7.	Packing.....	31
8.	B/w Work.....	32
8.1	Quick Reproduction.....	33
8.2	Development of B/w Negative Films.....	36
8.3	B/w Enlargement.....	38
9.	Advanced B/w copying.....	41
9.1	Diffuse Light Contact Printer.....	41
9.2	Unsharp Masking.....	42
9.3	Photographic Amplification.....	45
9.4	Superposition Frames.....	48
10.	Colour Work.....	50
10.1	Equipment.....	50
10.2	Procedures.....	55
11.	Cleanliness.....	59
12.	Silver Recovery.....	62
13.	Storage.....	66
14.	References.....	68
15.	Photographic material.....	69

1. Introduction

The ESO SAL was first set up in Geneva in 1972. At that time the ESO Council took the decision that an Atlas of the Southern Sky, based on photographic plates obtained with the ESO 1m Schmidt telescope should be produced by ESO. Earlier approaches to industry had clearly shown that it would not be advantageous to entrust a project of this dimension to commercial firms. The necessity of assuring the best possible reproduction of the original plates quickly led to the conclusion that in-house production and quality control were imperative for the project.

Consequently, a number of rooms in the basement of the SB administration building on the CERN site, adjacent to the ESO Telescope Project Group barracks, were transformed into photographic laboratories during the summer of 1972. A staff of four persons was established (1 astronomer/group leader, 2 photographers and 1 secretary). The inauguration of the Sky Atlas Laboratory took place in November of 1972, five months after the first astronomically valid plates were obtained with the ESO 1m Schmidt telescope on La Silla.

At about the same time, an agreement was reached with the Science Research Council (U.K.) that the SAL would produce the joint ESO/SRC Atlas of the Southern Sky, in addition to the Atlas based on ESO Quick Blue Survey plates.

The general principles of reproduction of large plates were known from the experience with the National Geographic Society/Palomar Observatory Sky Survey (POSS) which was first published during the 1950's. Close contacts were therefore maintained with the people who were responsible for the POSS. In particular, Mr. Wm. C. Miller, Chief Photographer at the Palomar Observatory, paid several visits to the SAL and his advice was instrumental in the decision to adopt techniques which represented an important improvement over those used for the POSS. A major innovation was the publication of the atlas fields on-film rather than on-paper. This was a significant advantage, since it now

became possible to extract information from the atlas copies by objective methods, e.g. by scanning with a microdensitometer.

With the changes in the ESO structure which took place after 1975 and the arrival of the first astronomers at the ESO group in Geneva, it soon became clear that there was a need for other, more general photographic work to be done within ESO. Thus, in addition to the atlas work, photographic reproductions were undertaken by the SAL in order to serve the daily needs of the astronomers and the Technical Group. A third photographer was employed on a part-time basis. Later, as the groups grew, this position became full-time.

The first measuring machine at ESO, an S-3000 Optronics two-dimensional microdensitometer was purchased in 1974 and placed in the room adjacent to the SAL. With the development of computer software for image processing (IHAP), much use was made of ESO Schmidt plates and copies thereof, through digitization at the S-3000.

In 1980, when all ESO activities were moved to the new headquarters building in Garching bei München, FRG, a unique opportunity presented itself. Based on the experience, won during 8 years in Geneva, it now became possible to redesign completely the layout of the SAL. The laboratory is now housed in the basement of the ESO headquarters building and has an area of approx. 400 square metres. Currently employed are: 1 astronomer/group leader, 5 photographers and 1 secretary, and the activities have been divided into two main sections: atlas and non-atlas work.

This report has been prepared for distribution at the meeting of the IAU Working Group on Photographic Problems (Commission 9) at the Royal Observatory, Edinburgh, on April 3-6, 1984. It gives in some detail information about the activities at the SAL and incorporates reflections upon many of the means and methods applied. It is hoped that it will serve as a useful inspiration

for others who already have established similar photographic laboratories or who contemplate to do so. It goes without saying that the SAL staff is always happy to discuss any matters connected with their work and to give advice to all who ask for it . Various reports about the Atlas work at SAL have been published earlier^{1,2,3}.

ESO Sky Atlas Laboratory
Karl-Schwarzschild-Straße 2
D-8046 Garching bei München, FRG
Tel.: (089) 320060, Telex 5282820 eo d

2. Laboratory Layout

The SAL is comprised of two subdivisions, the "Atlas Section" which deals exclusively with the production of sky atlases, and the "Photographic Section" which covers all other photographic work, from general photography to applied photography. Close interaction between the subdivisions is assured by regular staff exchange and use of common facilities. Yet they both maintain a certain independence, due to the different nature of their assignments.

The layout (Fig. 2.1) of the laboratories reflects this, with a "right" side (Atlas Section) and a "left" side (Photographic Section) as well as a number of rooms for common use (chemical mixing, plate vault, etc.). Adjacent to the photographic labs, there are several rooms with photomicrodensitometers. This implies that (original) plate material never has to be transported over larger distances within the ESO headquarters.

The SAL is a selfcontained unit in the building and, although non-photographic staff is not denied access, strict rules (e.g. prohibition of smoking) are applied in the entire working area.

In what follows, the functions of the individual rooms are briefly described. More details are found in the other Sections. An overview is presented in Table I.

ESO SKY ATLAS LABORATORY

2.1

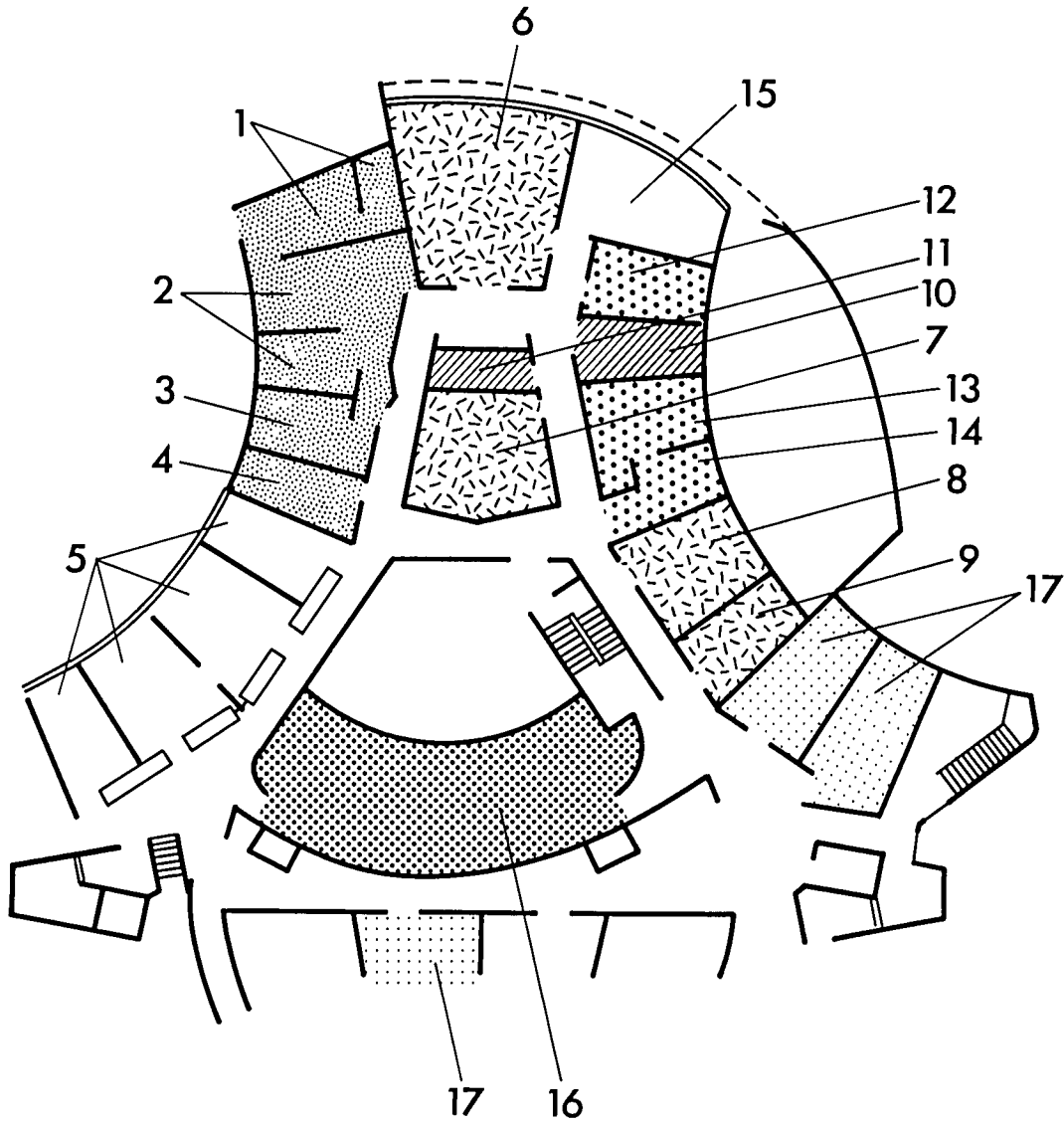

 Non atlas darkrooms

- 1. Colour lab
- 2. b/w printing
- 3. b/w processing
- 4. Reproduction

 5. Offices

 Storage and packing

- 6. Packing
- 7. Film storage
- 8. General storage
- 9. Chemicals storage

 Chemical mixing

- 10. Chemical mixing+
Silver recovery
- 11. Silver recovery

 Atlas darkrooms

- 12. Film copying
- 13. Plate processing
- 14. Plate copying

 15. Film inspection

 16. Plate vault

 17. Photomicro
densitometers

COLOUR LABORATORY

2.2

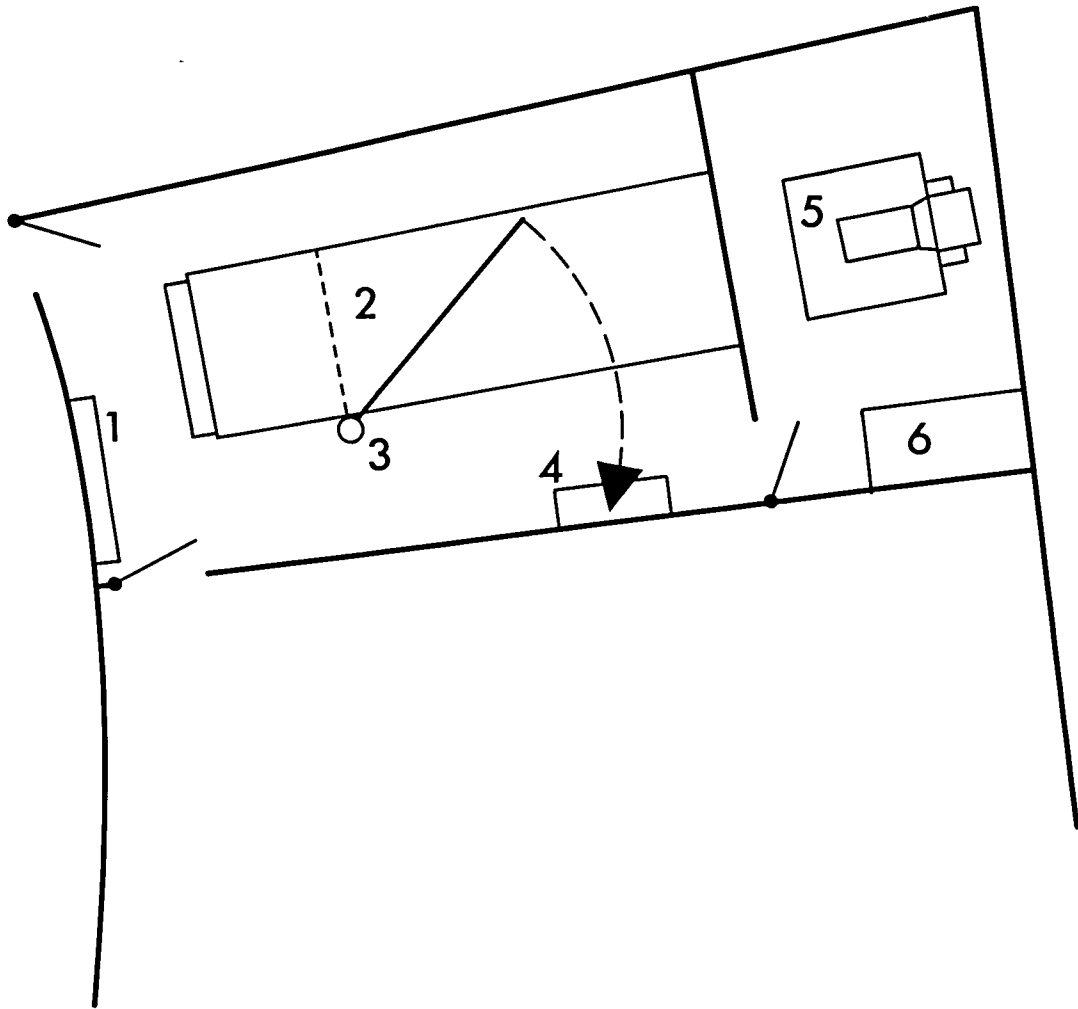

- 1.Shelf
- 2.Processing Machine
- 3.Hoist
- 4.Sink
- 5.Colour Enlarger
- 6.Light Table

MAIN BLACK AND WHITE LABORATORY

2.3

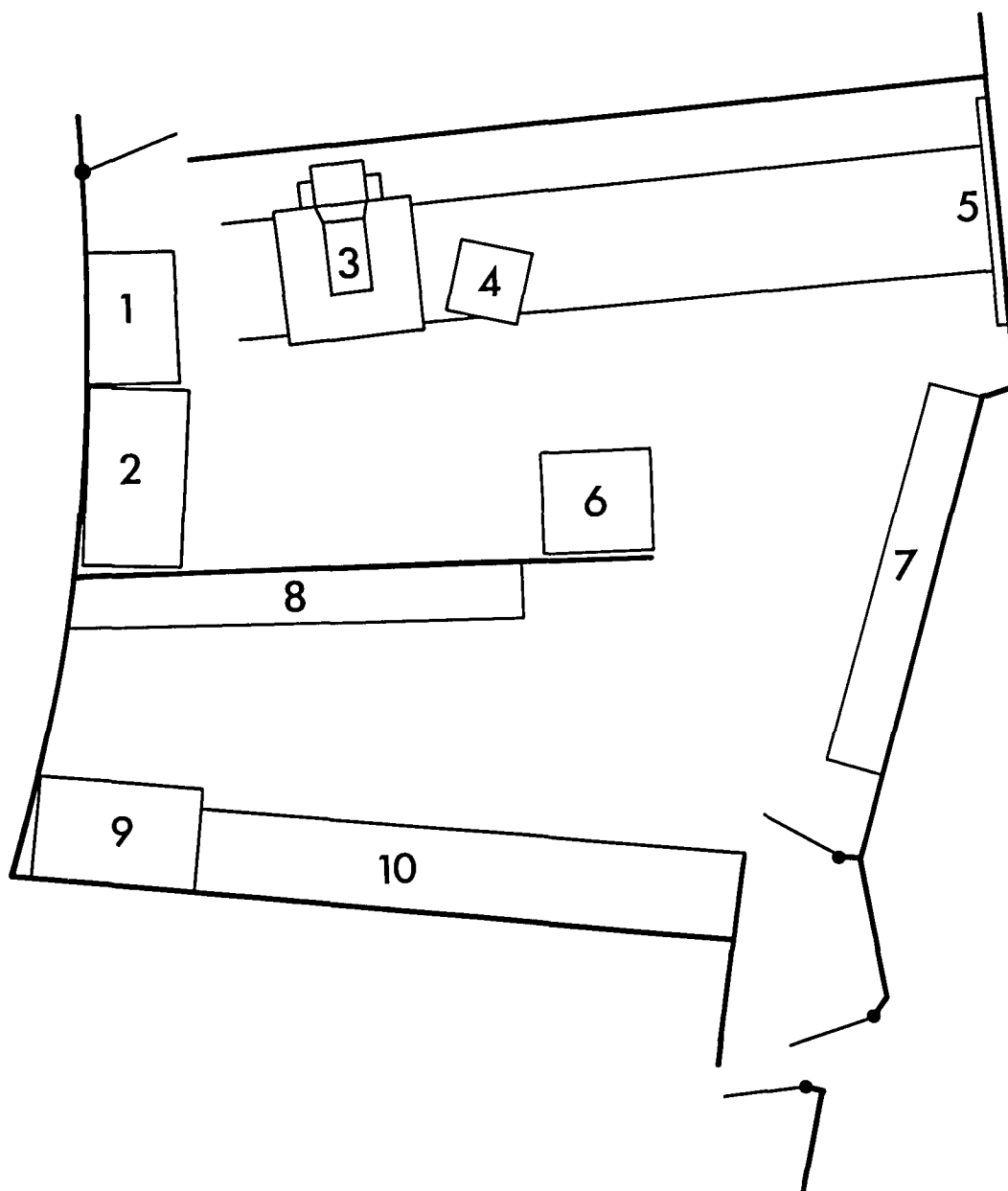

1. Table with contact printer
2. Light table
3. Black and white enlarger on rails
4. Trolley with enlarger operating panel
5. Projection plate for murals
6. Black and white processing machine
7. Shelf
8. Shelf
9. Contact printer
10. Sinks

Room 1 consists of two separate rooms: a small darkroom with a Durst colour enlarger (see Section 10) and a daylight room with an Autopan colour processing machine and auxiliary equipment for colour work (Fig. 2.2).

Like all other darkrooms it has an airconditioning system with dust filters (see Section 11) and air-filtering units which trap dust particles larger than 0.5 μm . The walls are painted with an easy-to-clean, hospital-type paint and dust-adhering carpets are placed in strategic areas. The floor of the larger room is covered with tiles (as are most labs at the SAL) to facilitate cleaning. Room 1 has an escape door to the exterior, which is opened during the preparation of colour chemicals which give off obnoxious fumes. A specially designed sink is used to clean the racks from the colour machine.

Room 2 is the main b/w darkroom of the Photographic Section (Fig. 2.3). It contains equipment for b/w printing (see Sections 8 and 9) and is divided into two major areas. A Durst b/w enlarger is placed in the middle of the larger area close to a Kodak X-omat b/w processing machine. The enlarger is supported on rails and can be tilted 90° to be used for wall projection. The smaller half of Room 2 is used for small format b/w manual processing (see Section 8). This room also contains two contact copying printers which are used for advanced b/w copying (see Section 9). Access to Rooms 2 and 3 is through a common lighttrap with electrically activated locks.

Room 3 contains a development tank line for manual b/w film processing and minor auxiliary equipment. It also serves for the development of very large paper murals and has appropriate sinks and trays for these purposes.

Room 4 houses a Klimsch compact-type reproduction camera with auxiliary equipment, including a small processing machine and a dryer.

The **office rooms** (5 on Fig. 2.1) with desks and other furniture for the personnel also contain SAL files and a negative library.

The contact with "customers" takes place in this area.

Room 6 has a large window area and serves as packing and inspection room for the atlases produced at the SAL. There are steel shelves along the walls for storage of atlas parcels and a large table with a machine to seal the envelopes with atlas films (see Section 7). A light table is used for final inspection of atlas copies before distribution.

Room 7 is kept at a lower temperature (approx. +16°C) and serves as storage for all photographic materials which are not kept in deep-freeze. It is rather large because of the necessity to store in-house at any given time a sufficient amount of plates and films for the atlas production to assure autonomy during several months. A small refrigerator is used for storage of small quantities of photographic roll films and other sensitive material.

Packing material, spare parts, etc. are stored in Room 8.

Room 9 contains the chemicals used in the production. In view of the large quantities of developer and fixer used for the atlas, this room has to be rather big. Here is also a deep-freezer (-30° C) for storage of particularly sensitive material (e.g. spectroscopic emulsions, etc.).

Room 10 is the main mixing room for chemicals (see Sections 11 and 12). Here are placed two mixing tanks for developer and fixer and a silver recovery unit which extracts silver from used fixer, received via internal pipes from the various darkrooms.

Room 11 In order to assure the best possible cleaning of effluents from the labs, a second silver recovery unit is placed here (see Section 12). It ensures that local pollution codes are strictly adhered to. This room also houses an ion-exchange demineralized water plant, which serves as an emergency reserve unit, should the central plant at ESO break down.

Room 12 (Fig. 5.1) is the site of atlas copying on-film (see Section 5). It contains two processing machines. The first, a Kodak Versamat 17, is regularly used for atlas copying. The second, a Kodak Versamat 317 which was used for this purpose in Geneva, is now retired, but is used occasionally as a stand-by and for other tasks. Here are also two Klimsch contact copying machines, one for atlas-work and one for special (mainly high-contrast) work. A Joyce-Loibl sensitometer is used for sensitometric control. Several air-filtering units maintain a high degree of cleanliness in this room.

Room 13 (Fig. 4.3) is the main processing lab for atlas glass copies (see Section 4). It contains an elaborate system of tanks etc. which ensures the best possible, safe processing of large atlas plates, from development to drying in a closed cabinet.

Room 14 (Fig. 4.1) is almost fully taken up by a clean air unit with a Freon cleaning machine and a vertical contact copying machine for glass plates (see Section 4). It also contains special boxes for drying atlas plates in Nitrogen before exposure. Rooms 13 and 14 are accessed through a lighttrap.

Room 15 serves as the main inspection room for atlas films and plates. The processed film copies exit from the processing machine in this room. There are two light tables with microscopes and various densitometers for the quality control of the atlas products.

Room 16 is the main plate vault (see Section 3) with 48 steel cabinets. All photographic plates taken with ESO telescopes will ultimately be stored here. The room is cooled to 16°C. There is also a Zeiss blink-comparator, a Polaroid facility (mainly to make finding charts) and a simple two-coordinate measuring table for 30 x 30 cm plates.

Three rooms (17 on Fig. 2.1) are occupied by measuring machines: a GRANT 800 one-dimensional microdensitometer for measurement of spectra, a two-dimensional PDS 1010-A microdensitometer and the S-3000 two-dimensional measuring machine.

TABLE I

Room No.	Function	Temperature	Safelights	Inlets	
1	Colour Printing	20°C	1 Durst Sanat Sodium Vapour Lamp	Air conditioning, Demineralized water Hot/cold water	380V 220V
1a	Colour processing	20°C	White light 5000 K		
2	Main b/w printing	20°C	Kodak filter 1A Kodak filter 0C 5 Kodak utility safelight lamps, model C 4 Kodak Universal safelight lamps, Type 2 4 Kodak adjustable safelight lamps, model A	Air conditioning 1 compressed air gun Demineralized water Hot/cold water	380V 220V
3	B/w film processing	20°C	Kodak filter 1A Kodak filter 0C 4 Kodak adjustable safelight lamps, Model A 3 Kodak Universal Safelight lamps, Type 2	Air conditioning Hot/cold water	220V
4	Reproduction	20°C	Kodak filter 1A 1 Kodak utility safelight lamp, Model C, 2 Kodak Universal safelight lamps, Type 2	Air conditioning Hot/cold water	380V 220V
6	Atlas packing and inspection	20°C	-. -	Air conditioning	220V
15	Main inspection, Atlas copies on-film and on-glass	20°C	-. -	Air conditioning Hot/cold water Compressed air connection	220V
12	Atlas copying on-film	20°C	Kodak filter 1A 4 Kodak adjustable safelight lamps, Model A and 2 Kodak utility safelight lamps, Model C	Air conditioning 2 compressed air guns	380V 220V
10	Main mixing	20°C	-. -	Air conditioning Hot/cold water, Demineralized water	220V 380V
13	Atlas processing on-glass	20°C	Kodak filter No. 1 9 Kodak utility safe-light lamps, Model C	Air conditioning Hot/cold/dem. water Fixer, developer	220V 380V
14	Atlas copying on-glass	20°C	Kodak filter No. 1 3 Kodak adjustable safelight lamps, Model A	Air conditioning 1 compressed air gun Nitrogen pipe	220V
8	Storage room Spare parts, packing material	20°C	-. -	Air conditioning	220V
9	Storage room chemicals	18°C	-. -	Air conditioning	220V
7	Storage room photographic material	16°C	-. -	Airconditioning	220V
11	Silver recovery	20°C	-. -	Air conditioning Exhausted fixer Demineralized water	220V 380V
16	Plate Vault	16°C	-. -	Air conditioning	220V

In Table I is given a summary of the various rooms, with their functions and properties indicated. As can be seen from the layout in Fig. 2.1, it was the intention to shorten the distance between rooms with related functions, but at the same time to separate the individual functions so that it is possible to do a variety of work simultaneously.

Most of the darkrooms have several outlets: hot/cold tap water, demineralized water, developer, fixer. The entire area is ventilated by a central air condition plant and kept at $20 \pm 1^\circ \text{C}$ (except where otherwise indicated). The humidity is also regulated to 50 ± 5 percent.

3. Photographic Plate Service

The SAL receives all plates taken with the ESO 1m Schmidt telescope. The plates are packed in special containers (see Section 7) and sent from La Silla with the weekly diplomatic bag. Upon arrival at the SAL the plates are inspected and the plate data entered into the plate computer file on the VAX 11/780 computer.

Atlas plates are subjected to a rigorous quality control before they are accepted. Until they have been reproduced for the atlas, these plates are stored in a special cupboard in Room 15 and are not accessible to anybody.

Plates taken for astronomers at ESO and elsewhere are meticulously packed and dispatched from the SAL to the persons who have requested them. Since all the plates remain ESO property, they must be sent back to the SAL for storage (in the Plate Vault) when the user has finished working with them.

Other photographic plates which are obtained on La Silla, are mostly taken back by the visiting astronomers who did the observations. These plates also remain ESO property and must later be returned to ESO.

GLASS PLATES PRINTER

4.1

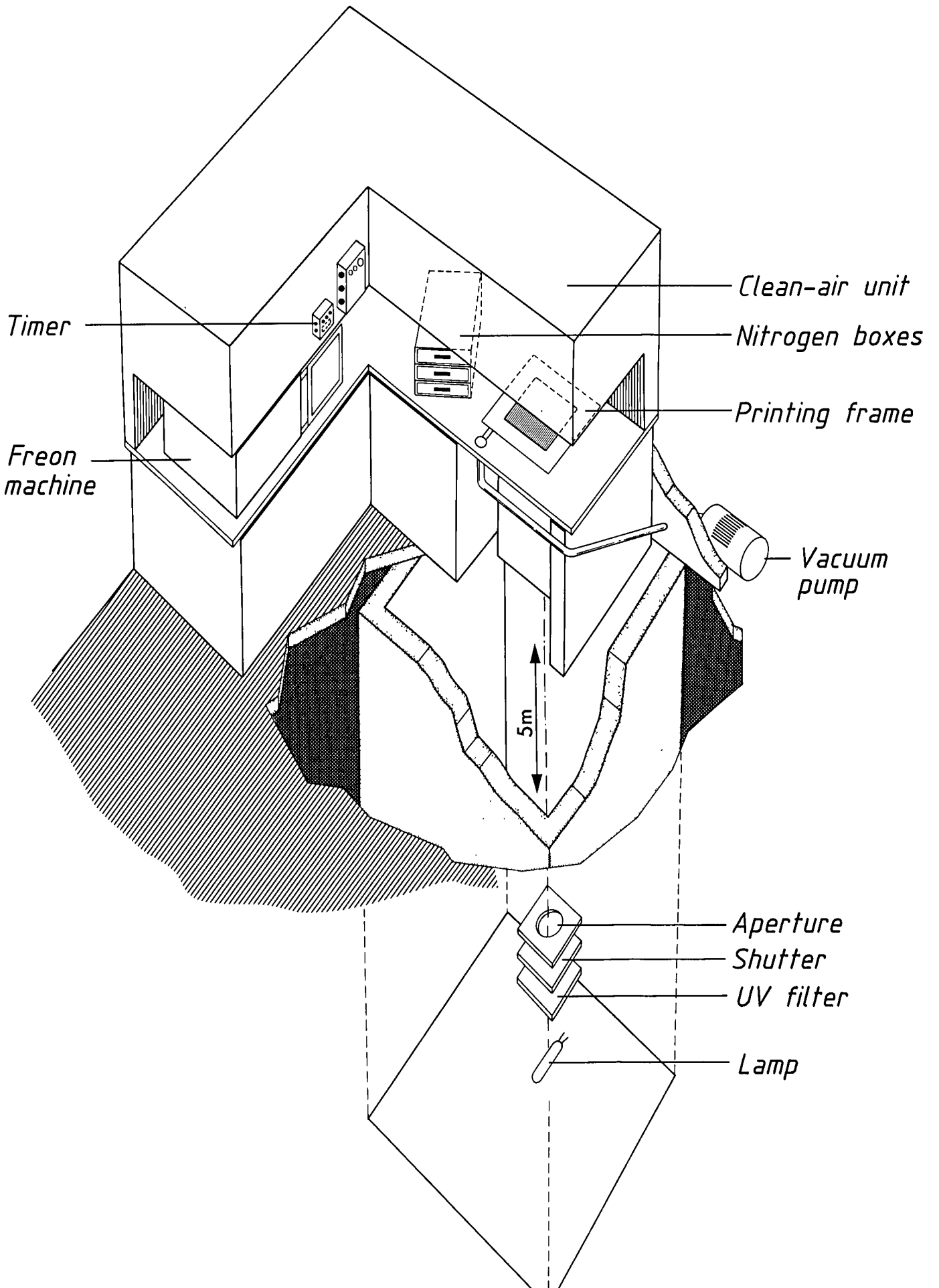

The SAL undertakes to provide copies and reproductions of all ESO plates available. In addition to the atlas production this type of work is an important function of the SAL.

4. Atlas Copying On-glass

4.1 Equipment

Plates which have been selected for inclusion in one of the atlases produced at the SAL, are copied on-glass in Rooms 13 and 14.

After a long period of testing it was decided to follow the example of the POSS, but with contemporary, improved photographic materials and procedures. Thus, the original plate is first copied onto an intermediate positive plate, which in turn is copied on-glass and on-film. To achieve the highest quality contact copies, it is very important that the environment is entirely clean (see also Section 11). Room 14 is therefore equipped with two clean-air boxes in which all on-glass copying operations take place (see Fig. 4.1).

The main installation in this room is a **printer** (Fig. 4.1) which is made of three parts: a frame, a lamp and a timer. Several frames were made specially for this purpose and one for each plate format is available. They are made of aluminium, blackened by anodic oxydation. This makes copying without a glass support possible and assures that there are no Newton rings and that the cleanliness is greatly improved. It is possible to copy smaller plates (e.g. 30x30 cm) directly onto larger ones (14x14 inch).

The frame (Fig. 4.2) is horizontally situated in the clean-air box in Room 14 with the light source below. The master (original or intermediate positive) is placed emulsion up in the frame and rests on an O-ring situated along the edges of the frame. The plate onto which the master shall be copied is placed emulsion down, on top of the master plate. The frame is closed and vacuum is established. The vacuum pump is placed outside the room to

COPYING FRAME

4.2

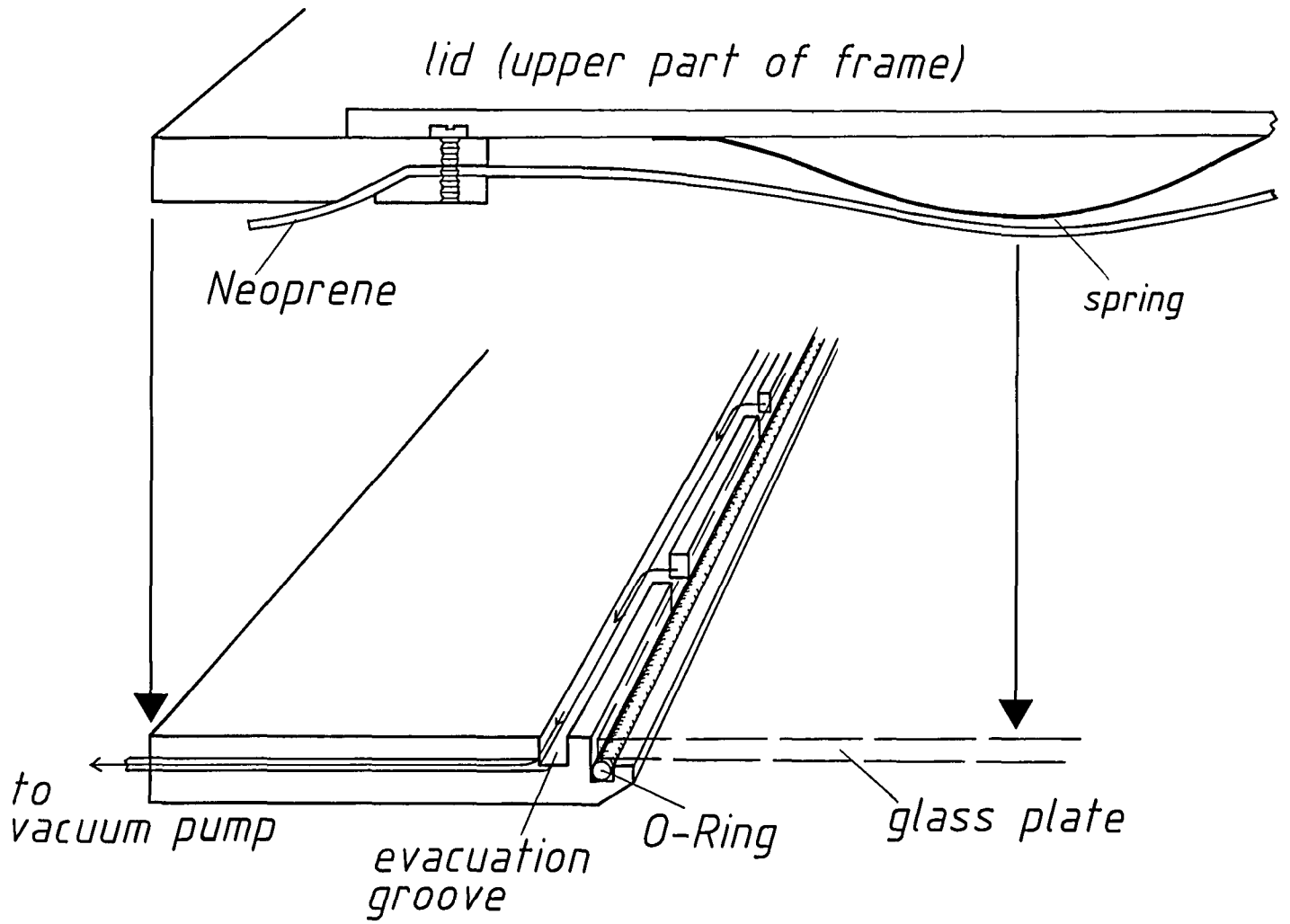

reduce the noise. On the tube which links the pump with frame, there is a manually controlled air-flow regulator to control the evacuation.

The **light source** is placed at the bottom of a shaft 5m below the frame. This shaft is made of concrete and is painted black. Air circulation is ensured by a ventilator which also prevents vapour condensation. Iron crampons lead down to the bottom of the shaft.

The light source consists of a quartz-iodine, slide projector type point-light bulb (24 Volt 150 Watt). Its beam is rather narrow, thus improving the reproduction. Due to the distance between the lamp and the frame, the illumination uniformity is better than 1 o/oo over a 35x35 cm plate. The light encasing is made of aluminium, black and matt like the frame. The lamp is centered at the bottom and cooling is ensured by two slits (light proof) on the sides of the box and a small ventilator. Above the lamp there are:

- an aperture (fixed once and for all)
- a shutter (linked with the timer)
- a UV Kodak filter 18A. (UV light does not penetrate deeply into the emulsion. Therefore there is no light dispersion within the emulsion layer of the plate. Tests have shown that the "surface" image obtained with this type of light improves the copying of very faint features).
- a big shutter (linked with the vacuum pump) to keep the light box clean.

We use a Durst **timer** with digital display combined with a power stabiliser.

A **Freon machine** is placed inside the clean-air box. It is an improved version of Millikan and Schoening's prototype. It was made specially for SAL by CERN in Geneva.

Freon cleaning removes lipids (e.g. fingerprints and dust particles) on the plate. It also neutralizes static electrical charges.

GLASS PLATES PROCESSING

4.3

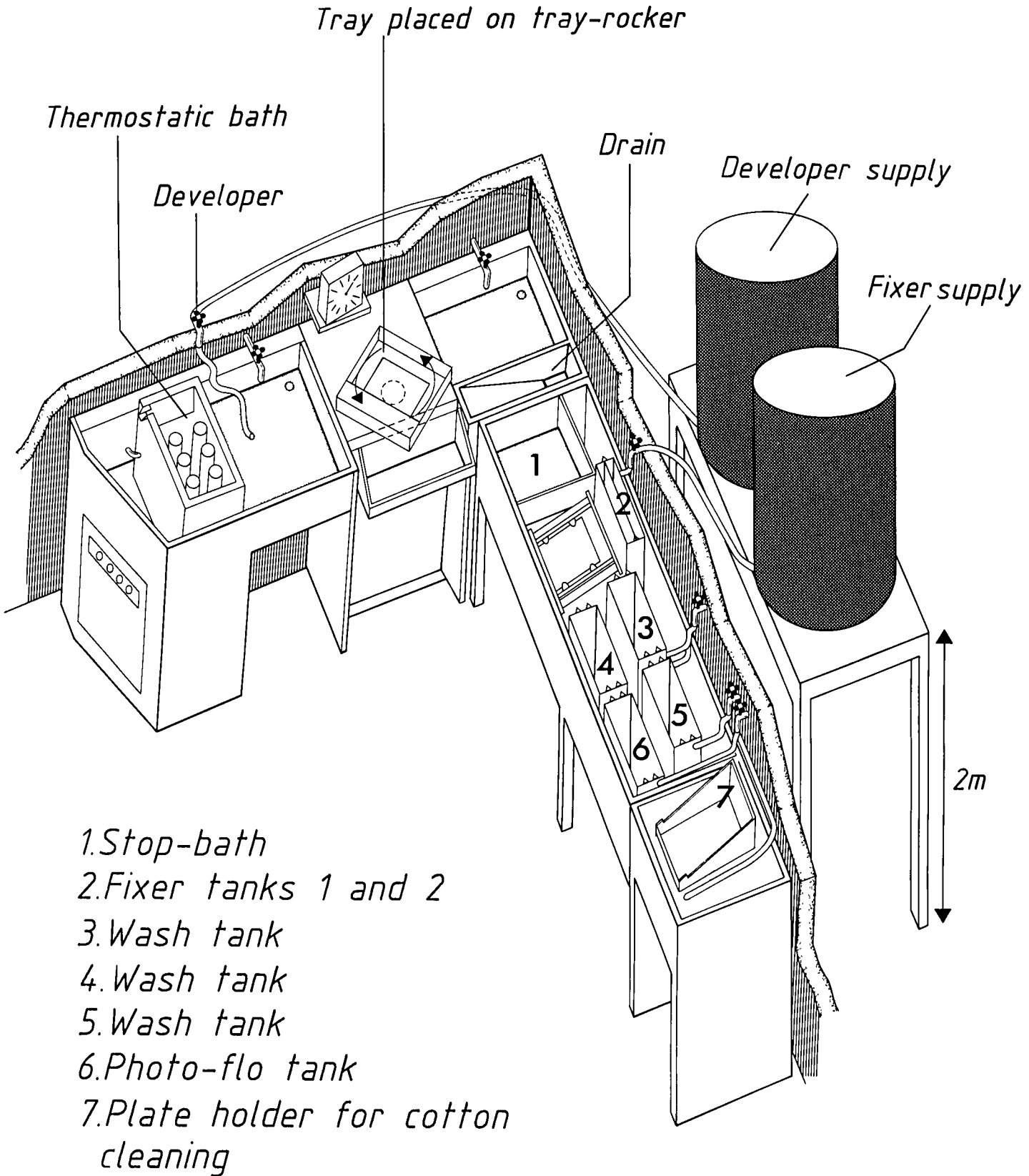

This lab is equipped with **compressed air** for plate cleaning (4-5 bar). Compressed air comes from an oilless compressor (placed in another room) and is filtered three times:

- Filter 1 removes water and oil
- Filter 2 removes possible water residuals, and
- Filter 3 in the air-gun retains all particles larger than 0.5 micron.

To complete the equipment of this lab, we have **nitrogen boxes**. Nitrogen has been introduced because of trouble in retaining the quality of the master when many copies (5 to 20) are made. The master deteriorated rapidly after 4 or 5 copies, particularly in the centre, because the emulsion of the copy plate absorbs water vapour from the air and tends to adhere to the emulsion of the master while in close contact during the vacuum phase. The repeated strain led to the master losing tiny bits of its emulsion which were "stolen" by the copy plates.

By keeping the copy plates for two hours in nitrogen (20°C) before copying we now remove the water contained in the emulsion and we have no problems making 20 copies of equal quality from the same master plate.

The boxes are made for six plates each. There is an inlet for nitrogen and an outlet for air. Once the boxes are loaded with plates and the cover tightened, nitrogen is let into the boxes while the outlet remains open. 15 minutes later the air has been replaced by nitrogen and the outlet is closed. A slight over-pressure (below 100 gr/cm²) is maintained in the box. In case of too much pressure (above 100 gr/cm²), a security valve releases the excess nitrogen.

Room 13 (see Fig. 4.3) is used exclusively for processing glass plates. A suitable processing machine for large format glass plates is not available on the market. Manual processing requires much hard work. Thus, this lab was conceived in order to obtain the best possible processing quality with a minimum of physical effort as well as no unnecessary waste of time. This required careful selection and positioning of the equipment. All furniture

is made of hard PVC and stainless steel. The room is kept at $20^{\circ}\text{C} \pm 1.0^{\circ}\text{C}$.

Before processing the temperature of the developer must be brought to exactly 20°C . We use thin (0.5 mm) stainless steel cylinders with a capacity exactly equal to what is needed for one plate. They are filled with developer and then kept in a water bath, the temperature of which is continuously checked and thermostatically adjusted (the accuracy is $\pm 0.2^{\circ}\text{C}$). Development takes place in a tray which is placed on a **tray-rocker**. The plate is fixed in a PVC frame which is immersed in the developer while the tray is in an upright position. The tray is then lowered smoothly onto the tray-rocker in such a way that the initial wave of developer rolls quietly over the emulsion, avoiding the formation of bubbles. The depth of the developer is between 7 and 10 mm (above the plate). The tray-rocker assures excellent uniformity of development for glass plates.

Following development the plate is transferred into a light metallic frame where it stays until the Photo-Flo Bath. The conservation of glass plates depends mainly on the quality of fixing and washing. Plates are fixed twice: There is strong agitation, maintained by a circulation pump, in the first fixing bath. It is renewed when 20 (14 inch) plates have been fixed. The second fixing bath has no agitation and is also renewed once for every 20 plates. Each plate goes through five washing baths. The washing tanks are supplied with water at $22-23^{\circ}\text{C}$ at the rate of 800 litres per hour. The minimum washing time is 45 minutes.

The dryer is of the normal photographic type. The plates are placed vertically on a wooden support with one corner down to ensure that excess water runs off quickly.

Kodak Safelights with filter 1 (dark red) are used in Rooms 13 and 14 (min. distance 1.5 metre).

4.2 Copying Techniques for Glass Plates

The plates used to make intermediate positive or negative atlas

copies from original plates are exclusively of the type "Kodak Process" (3 mm thick and with anti-halation backing). Until exposure they are kept at in the storage room (Room 7). They are exposed well before the indicated expiration date, since old plates normally show non-uniform patches. In what follows, we describe the individual steps, from exposure to drying. The plate to be copied is called the "master" plate; the other, upon which a copy of the master is made is called the "copy" plate.

4.2.1 Plate Cleaning

Master and copy plates are cleaned in the Freon cleaning machine whenever necessary. The following procedure is followed:

- The glass plate is placed in a vertical support frame, which slides into the machine and the slit door is closed.
- Both plate sides are sprayed simultaneously with freon through 8 nozzles (4 on each side). The nozzles move rapidly from the top-downwards. The amount of freon used for one plate is 0.8 l and the pressure is 5 bar.
- Four minutes later the plate is dry and ready to be exposed. The atmosphere within the machine must be saturated with freon; too rapid evaporation of the freon leaves marks on the surface of the plate.
- After use the freon is filtered and passes through a water-separating tank. This removes any condensation water in the Freon, which would otherwise cause water streaks on the next plate.

The reverse side of the master plate (original or intermediate positive) must be cleaned carefully. The residuals of the backing and other stains are removed by means of repeated rubbing with alcohol and with several pieces of medical gauze. Before the plate is placed in the frame, the reverse side is examined in detail in grazing light and any dust specks are removed with an air gun from close range. The master plate is then placed in the printer frame, with the emulsion upwards. This surface is very sensitive and can only be cleaned with the air pistol; however, this action is normally sufficient to remove all dust. Again,

grazing light is used for checking. The copy plate which has been dried during two hours in nitrogen (see above) is then taken out of the box and placed in a specially made cleaning frame with the emulsion side facing the operator. It undergoes the same air cleaning as the master plate. Then the copy plate is gently placed emulsion down on top of the master and the printer lid is closed.

4.2.2 Vacuum

The lid of the frame is tightened with two screws (Fig. 4.2). When the frame is closed, a small piece of metal applies a gentle pressure in the centre, so that the evacuation starts in the middle. Experience has shown that to avoid air pockets between the two plates, it is necessary to use the following step-by-step procedure:

- a) With the help of the air-flow regulator, vacuum is slowly increased to 40% (60% atmospheric pressure remaining).
- b) After a short break, we increase to 60 %
- c) then down to 50 %
- d) up to maximum
- e) down to 70%
- f) Maximum vacuum (about 80%) is then established and held during two minutes before the exposure takes place.

After exposure and opening of the frame, two minutes are allowed for the copy plate to disengage itself from the master.

This rather lengthy procedure is absolutely necessary in order to avoid the risk of bad contact between the plates and the resulting defocussed areas on the copy plate.

4.2.3 Plate Processing

The following steps are made at the SAL for atlas copies:

Development - Kodak D76 developer at 20°C

positive → 4 minutes

negative → 4 1/2 minutes

NB: The developer is renewed after every plate.

- Tray-rocker - 14 inch plates → 25 rocks/min
(2 rotations/min)
- 30 cm plates → 19 rocks/min
(1.5 rotations/min)
- Stop-bath - 120 ml acetic acid (60%) in 6 l of water,
30 seconds with strong agitation
- Fixing - Kodak Unifix at dilution B (50 l)
First bath → 5 minutes, with agitation in
tank, renewed every 20 plates and then used
as second bath.
Second bath → 5 minutes, renewed every 20
plates.
- Washing - Tap-water at 23°C in five successive tanks with
running water (800 litres per hour). Total time
about 45 minutes.
- Cotton-wool cleaning - To remove the insoluble salts which remain
on the emulsion surface, we rub this side gently
and carefully with a piece of cotton-wool after
washing. At the same time, demineralized water is
poured over the plate. The reverse is also
cleaned, if necessary.
- Photo-Flo - Kodak Photo-Flo solution, 60 ml in 36 l de-
mineralized water. Immersion time → 4 minutes.
Filtered Photo-Flo is poured over the plate to
remove any remaining piece of emulsion, coming
off the edges.
- Drying - Plates are left overnight in the drying cabinet
(no heating and no ventilation). In the morning,
ventilation and heating are switched on during

ATLAS COPYING ON-FILM EQUIPMENT

5.1

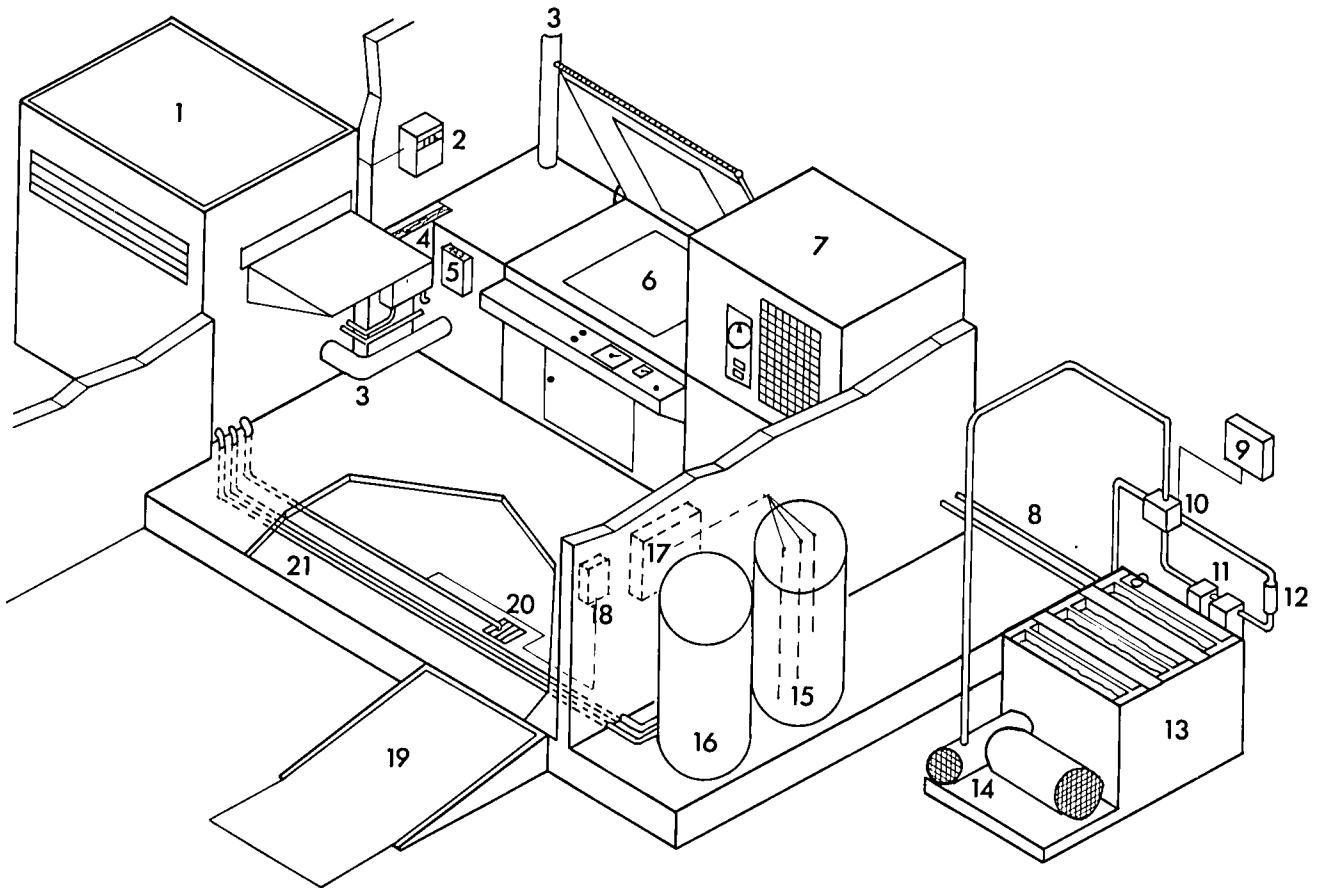

- | | |
|---|---|
| <p>1.Kodak Versamat 17 film processor</p> <p>2.Digital velocity meter</p> <p>3.Air exhaust pipe</p> <p>4.Fixer level control</p> <p>5.Automatic film counter</p> <p>6.Klimsch Vakuprint</p> <p>7.Sterile airflow box</p> <p>8.Fixer circulation pipes</p> <p>9.Compressed air electro valve</p> <p>10.Pneumatic main valve</p> <p>11.Fixer cartridges</p> <p>12.Fixer circulation flow control</p> <p>13.OMAC silver recovery unit</p> <p>14.Circulation pumps</p> <p>15.Fixer replenishment tank (100 l)</p> <p>16.Developer replenishment</p> <p>17.Signal horn for fixer level</p> | <p>18.Drain signal horn</p> <p>19.Dust adhering carpet</p> <p>20.Emergency drain</p> <p>21.Developer/fixer replenishment pipes.</p> |
|---|---|

30 minutes. The plates are removed from the dryer and placed in TYVEK envelopes. (see Section 7).

5. Atlas Copying On-film

Most copies of the atlas produced at the SAL are made on-film. The films are contact copies of the intermediate positive plates which are made as described in Section 4. The production takes place in Room 12 (see Fig. 5.1).

The decision to produce the atlas on-film rather than on-paper as the POSS, allows the user to make accurate measurements on the atlas copies. Much exploratory work was necessary to decide about the reproduction techniques, but it is believed that the current procedures are optimal for fidelity and archival quality.

5.1 Equipment

A Klimsch Vakuprint contact printer is used for copying on-film (Fig. 5.2). The printer has point and diffuse light sources, but only the point source is used for atlas work in order to obtain the best possible reproduction.

A series of tests showed that it is best to use an iodine-quartz lamp (24V/150W) behind a Kodak UV 18A filter (same as for glass plates). The filter is placed ~ 7 cm above the lamp. Due to the relatively small distance (80 cm) between the lamp and the copy frame, a rather serious cosine effect is present. In order to provide a uniform illumination, a correcting lens is installed by the manufacturer. Still, we found that there was a difference of illumination of ~ 15 % between the centre and the corner. To overcome this, the lens has been replaced with a film mask which reduces the difference to less than 4 percent. The mask is made by exposure in the printer and is placed at 15 cm distance from the lamp. It is produced on Kodak Commercial film (intensity 20 % of normal, exposure time 5 seconds, development 2 1/2 minutes in Tetenal Dokulith 20°C). The mask is replaced at regular intervals and test exposures are made in order to control the uniformity of illumination.

CONTACT PRINTER KLIMSCH VACUPRINT

5.2

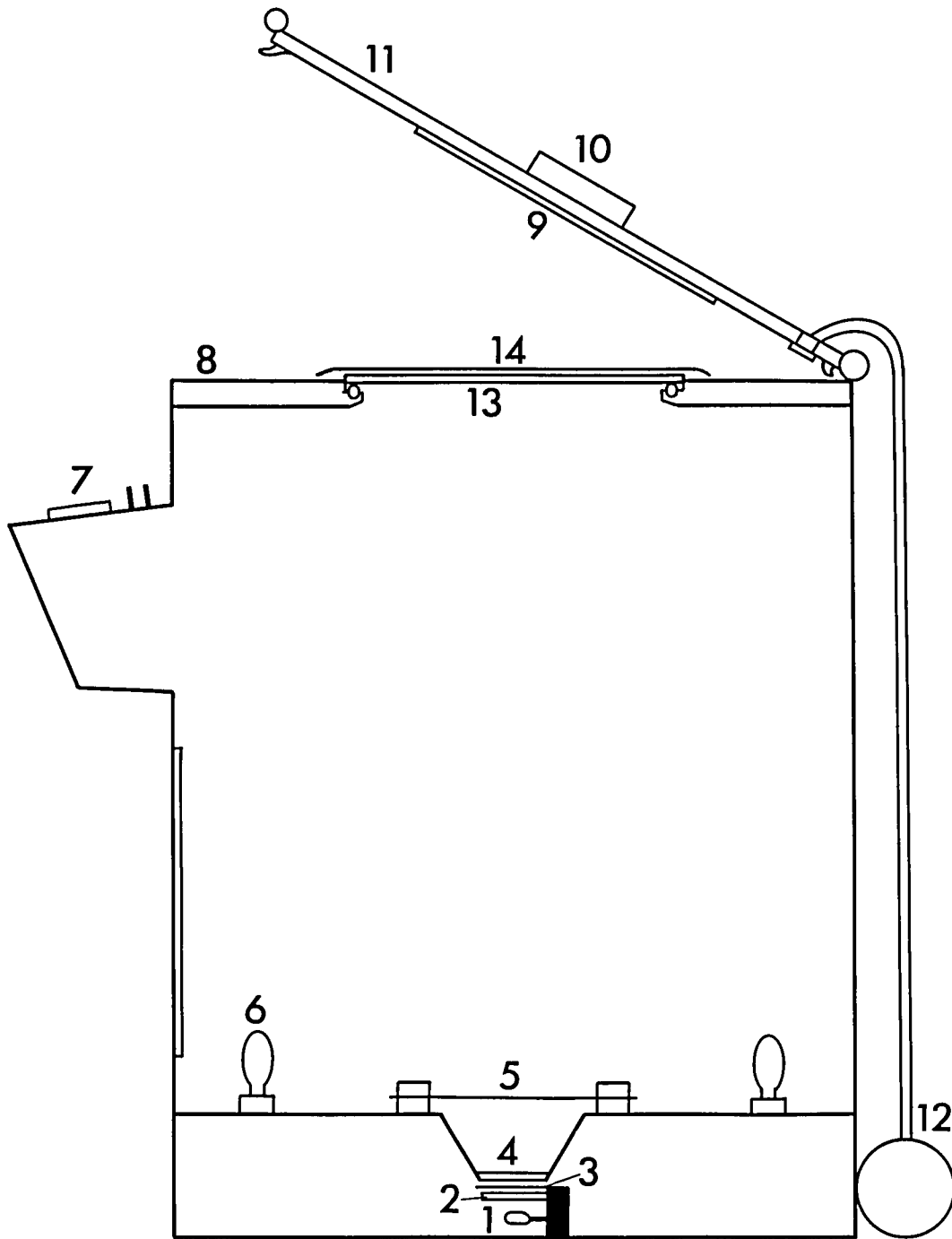

- 1.Lamp
- 2.Anti-heat filter
- 3.Shutter
- 4.UV-Filter
- 5.Film mask
- 6.Diffuse light

- 7.Operating panel
- 8.Copy frame
- 9.PVC
- 10.Weight
- 11.Rubber carpet lid
- 12.Vacuum pump
- 13.Master plate
- 14.Film

A serious problem with the Klimsch Vakuprint was that the images of many copy films were unsharp, due to air bubbles which remained between the intermediate positive plate and the film, when the vacuum was established. In this way, a good contact was not achieved and smaller or larger areas had a "woollen" appearance. To overcome this problem, a small weight is now placed on top of the rubber carpet lid of the printer. The weight assures that there is a good contact between the film and the intermediate positive in the centre, so that the air is evacuated simultaneously on all sides and no air is "left behind". As an additional safety feature, a PVC plate which has exactly the same size as the intermediate positive, is fixed on the lower side of the lid of the printer. Furthermore, the efficiency of the vacuum is improved by a gradual, step-wise evacuation. The first step brings the vacuum to ~ 40% and the second to about 80. When this level is reached, the exposure follows automatically.

Finally, the printer frame on which the intermediate positive glass plate is fixed had to be re-designed. The large glass plate installed by the manufacturer was removed and replaced by an anodized aluminium plate. The intermediate positive is supported by this plate on an O-ring towards which it is pressed when the vacuum is pulled. In this way, no air can enter from below.

Following the exposure, the atlas films are developed in a Kodak Versamat 17 developing machine. This machine is particularly well suited for the production of large quantities of atlas copies, because it has a large tank volume (36.8 litres). Hereby the rate of regeneration of developer and fixer, as well as small exterior temperature variations are less critical.

In order to assure a sufficient degree of cleanliness in this machine, all inlets (water, developer and fixer) were fitted with filters. Several other changes were also made, e.g. the distance between neighbouring rollers was increased since the films originally tended to get stuck in the rollers. Moreover, the leading edge of the film sheet was pressed against the rollers causing a mark. These marks in turn resulted in a

line on the films, ~ 7 cm (= one roller revolution) from the edge.

The entry into the tank of regenerator developer was not satisfactory. Due to the particular geometry of the entry nozzles jets were created which were directed towards the edges of the films so that these areas were more efficiently developed. This led to a density gradient and an overall difference over the area of more than $\Delta D = 0.01$. A metal plate has been installed which deviates the jets so that they do not hit the films directly. It was also necessary to install a digital velocity meter which shows even very small changes in the film speed. The serial meter was much too inaccurate for our purposes.

Another modification was made at the exit of the Versamat 17. Since the films, in particular during the dry winter months, frequently bent due to electro-static charges, an ion generator was installed to eliminate the electrical field.

Of particular interest is also the rather complex circulation of developer and fixer. This system is described in Section 12.

5.2 Procedures

The actual production of atlas copies follows procedures which have been established in order to assure the best possible reproduction, minimal variations from copy to copy and as little as possible contamination by dust etc. Originally, Kodak Aerographic Film 4427 was used, since it combines a good resolution with a reasonable contrast. In order to obtain a $\gamma = 1$ reproduction, it was necessary to expose in UV light and to underdevelop the film. Later, Kodak produced the similar, but slower and more fine grain 4421 Aerographic Film which has been used at the SAL since 1980. The order No. is SO-261.

The 16"x16" (40.6 x 40.6 cm) films are stored in Room 7 in Kodak boxes of 50 films each. Before they are used, the films are removed from the box and placed in a light-tight metal dispenser (Fig. 5.3) from which they can easily be removed one by one.

METAL FILM DISPENSER

5.3

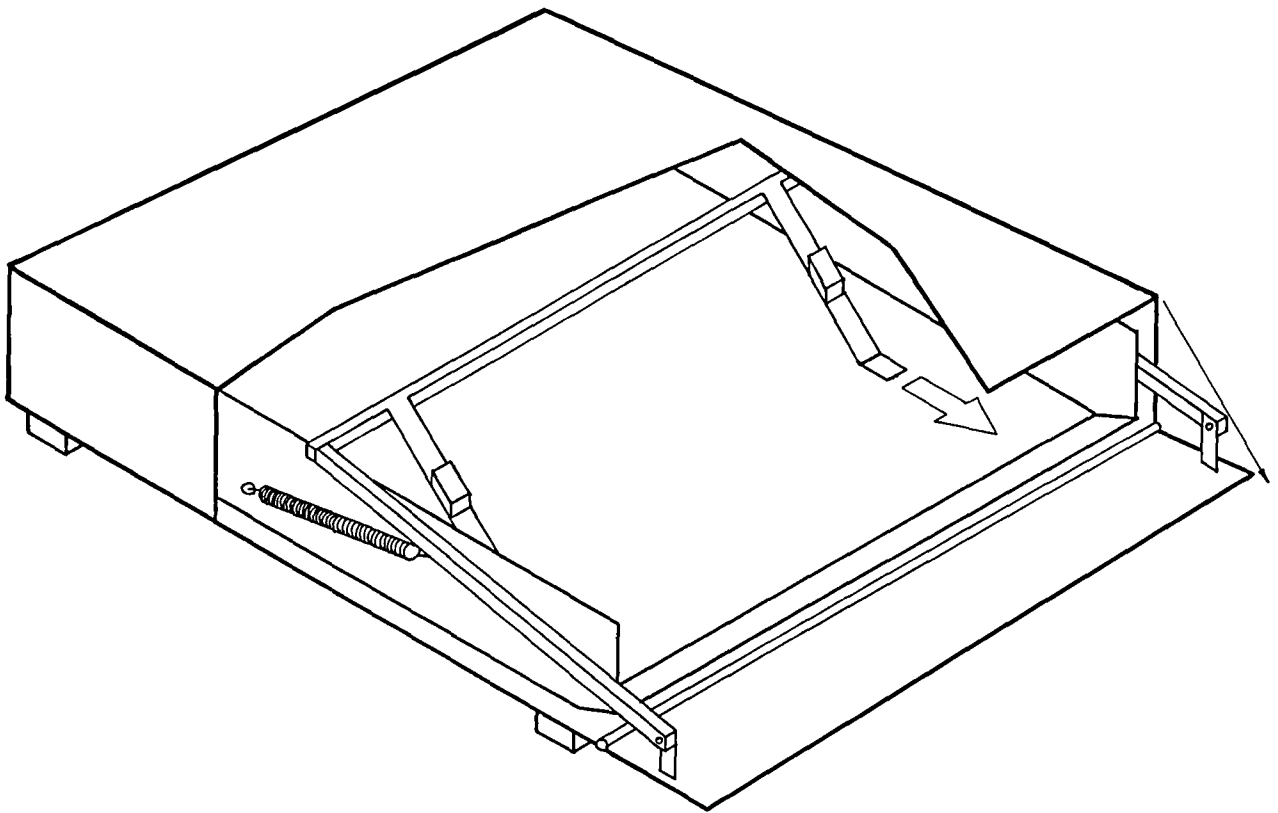

The exposure takes place at the Klimsch Vakuprint in a red illumination (Kodak Safelight 1A). The area around the plate frame is embedded in an air stream emanating from a hospital-type sterile air-flow box. Careful and regular control of the exposure and the processing is done by test films (see Section 6). When the film has been exposed, it is inserted into the Kodak Versamat 17 developing machine from which it exits 8 minutes later in Room 15. It is provisionally inspected on a light-table under a microscope with 50x power. Finally, it is transferred to Room 6 for packing and dispatch (see Section 7).

During one working day it is possible to make approx. 150 films. This, however, implies perfect functioning of all machinery. Due to the necessity of maintaining very constant conditions, it is often necessary to stop the production to correct minor deviations. Still, many years of experience have made it easier for the operator to foresee such events and take correction measures early enough to avoid serious disruption of the production.

6. Quality Control and Sensitometry

Sensitometry plays a major role in the quality control of atlas copies on-film and on-glass.

In order to assure a uniform production of atlas films, rather strict sensitometric control must be exercised. At the beginning of the production of a series (180 copies of the same field), an initial test film is exposed and compared with the original plate. The sharpness of reproduction (correct rendering of individual grains) and cleanliness of the film (no dust specks, etc.) are given particular attention. The density of the films is measured with a Macbeth Densitometer TD 502 and the inspection of the copy films is done with a microscope (50x enlargement). If all criteria are satisfied, the serial production can begin. However, it is necessary to repeat the procedure regularly and to perform frequent quality controls on films in the series. Errors may arise during the exposure (aging of the lamp, insufficient

vacuum) and there may be dust on the intermediate positive. Often errors occur in the development (variation of the temperature of the developer, variation in the development time, wrong rate of regeneration, dirt in the developing machine, etc.).

In order to avoid all of these errors or at least to become aware of them as early as possible, the following test procedures have been adopted:

- 1) Whenever 20 films have been processed, one copy is taken from the series and compared in detail with the initial test copy.
- 2) After every 50 films a step wedge is exposed on a film by means of a Joyce-Loibl Sensitometer and developed. It is measured at the densitometer and the resulting developer activity curves (Fig. 5.4) compared with a standard curve. In case significant deviations are detected, corrective action is taken by means of variation of regeneration rate.
- 3) Every time a series (180 films) is finished, another step wedge is exposed at the printer in order to determine the γ -value of the development process.
- 4) Furthermore, two step wedges are exposed on the same film, one at the printer and one at the sensitometer. From the measured densities, as compared to the standard values, it is possible to determine the state of the printing lamp, and to detect at an early stage any aging effects.
- 5) During the work, the operator is kept informed by digital displays about the state of the Versamat (speed and temperature). In case any rapid variations are seen, corrective action is taken immediately and the films currently in the machine, are submitted to individual quality control when they exit.

The control of the atlas glass plates is done with the same criteria as those applied to the film copies. However, it is unavoidable that the manual processing is subject to minor

DEVELOPER ACTIVITY CURVES

5.4

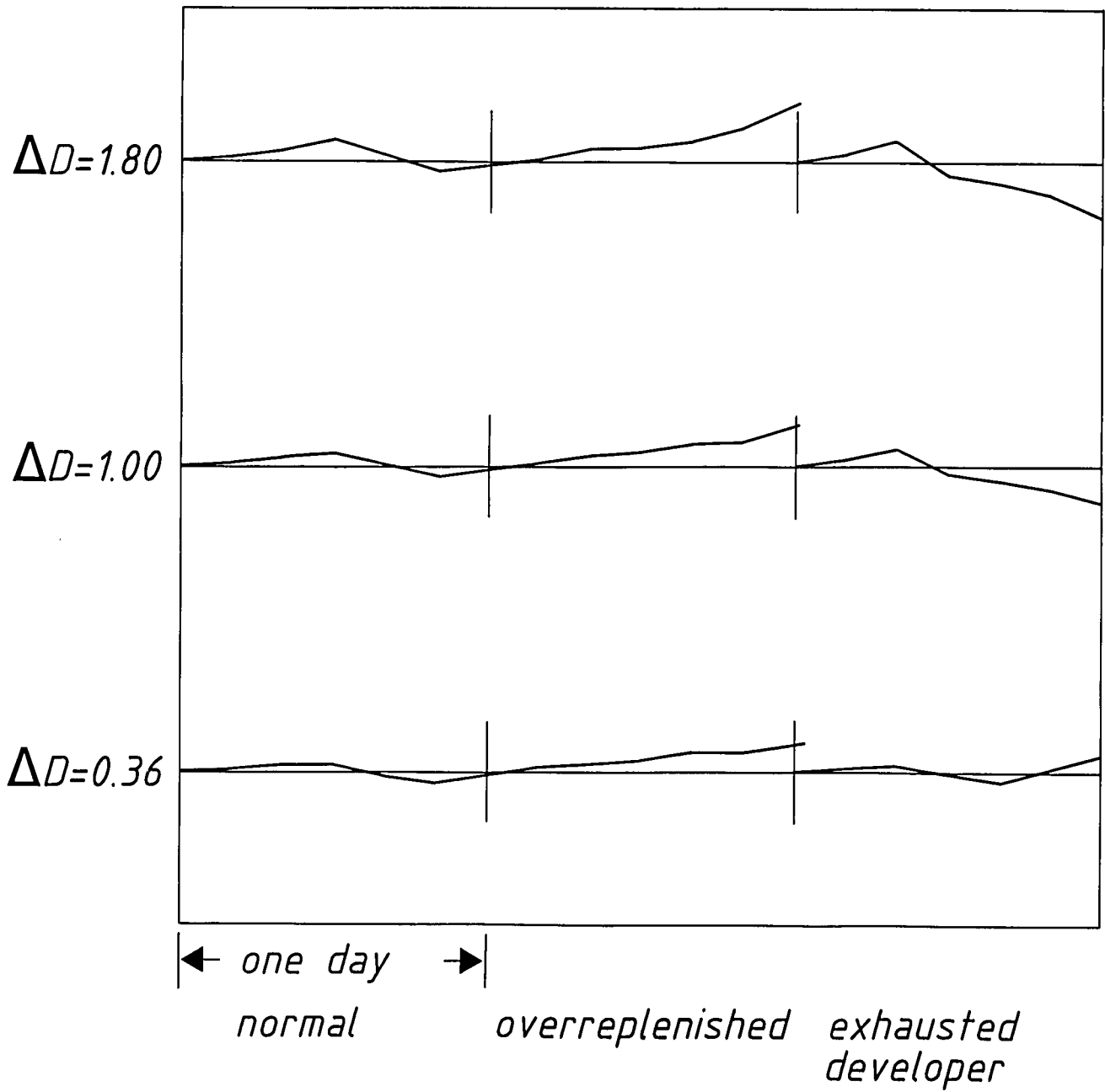

variations. Whereas the uniformity is normally excellent, it is not trivial to achieve the correct background density of the atlas copies (also here the standard value is 0.35 D). However, after a long experience the operator is able to achieve the standard background value with deviations less than $\sim \pm 0.02 D$, by applying corrections to the exposure time whenever necessary.

One problem, which has been given special attention is the need to have very uniform exposure over the entire surface. As mentioned earlier, this is taken care of by having a large distance between the lamp and the plate frame in the glass plate printer, and by a special filter with a radially variable density in the printer where atlas film copies are made.

At regular intervals, plates and films are exposed directly to the printer lamps. The resulting density is measured in small squares all over the area. The mean density and the r.m.s. value are calculated. It is found that in all cases, the r.m.s. value is smaller than $\pm 0.02 D$ over a 14"x14" plate. In view of the other errors inherent in photographic photometry, this is considered quite acceptable.

7. Packing

The film copies are moved to the Packing Room (Room 6) after development and quality control. They are again inspected and then put in protective envelopes (16"x16"). The air is evacuated and the envelopes are sealed by a special heat sealing machine. The envelopes are transparent and consist of two layers which are glued together. The interior is soft (polyethylene) and does not scratch the films. Special care is taken to eliminate all dust on the film before it is enclosed in the envelope. The exterior side is hard (mylar) and more resistant to scratch so that it can be repeatedly subjected to wear. Nevertheless, it may become necessary to exchange the envelopes of films which are particularly frequently used. Spare envelopes can be obtained from the SAL on request.

Atlas copies in their envelopes are packed in lots of 50

into a heavy-duty plastic bag which is also sealed. This bag is placed in specially made cartons and dispatched to the customers of the atlas by surface mail. Experience shows that very few cartons are damaged in transit.

Atlas copies on-glass are controlled under a 50x power microscope and placed in specially manufactured TYVEK envelopes. This material does not scratch the photographic plate, it is chemically inactive and is very tear-resistant. This has the advantage that it is no longer necessary to use an interior envelope as was earlier the case for Schmidt plates.

The glass plates are packed in lots of 20 in specially made wooden boxes, within a protective layer of styropor. The box is closed and the lid is tightened with steel bands.

The boxes are sent via surface and ocean freight. Very few breakages have been reported. In all cases the SAL has provided the customers with replacement copies, free of charge.

Original Schmidt plates are transported from the La Silla Observatory to SAL in the same type of boxes. To provide extra protection, the wooden boxes are surrounded by a spongy material which absorbs shocks during the transport. No original plates have ever been broken in transit.

8. B/w Work

Copies of astronomical and other photographs are frequently needed for different purposes, e.g. illustrations of publications. Thus, when the atlas production started in Geneva, it soon became apparent that it was necessary to equip the SAL with a variety of instrumentation for general photographic work as well.

Different types of photographic work are encountered at an observatory. Astronomers need finding charts for their observations and copies of their plates for illustrations in the resulting articles. Technical personnel need photographs of

apparatus, some of which is built at ESO. It is necessary both to provide contact copies and enlarged or reduced copies. The work in the b/w lab centres on these types of work, but to some extent includes also the production of publicity material for astronomy in general and ESO in particular.

8.1 Quick Reproduction

When a large volume of photographic work has to be done by relatively few people, the best way to assure timely completion is to have adequate, highly automated equipment.

An example of photographic work which repeatedly has to be done is the reproduction of drawings, at a reduction rate or scale which is set by the astronomer or technician. To carry out such tasks, the SAL is equipped with a German-made Klimsch Autocompact SE Reproduction camera in Room 4 (Fig. 8.1). This is a compact-type (i.e. vertical) camera which handles original drawings or photos up to 60x85 cm formats. Fitted with a revolving lens holder, reductions or enlargements between 12-800% can be made. However, the camera back (i.e. the horizontal vacuum lid) which holds the copy material will not accommodate material larger than 55x65 cm. With the lenses selected by SAL (150 mm, 340 mm, 300 mm), maximum enlargement is 500%, reduction 20%.

Fitted with a micro-processor, the camera offers automatic setting of the preselected reduction/enlargement factor (repeatable to ± 0.04 mm), automatic focussing (manual ground-glass focussing possible), automatic calculation and execution of single or multiple exposures (e.g. preflash and main exposure), properly adjusted for extension of bellows, selected lighting and low intensity reciprocity failure characteristics of the reproduction material in question. The micro processor features nine programmes for simple (single exposure) line work with different photographic materials as well as the choice between the proper illumination for reflection or transparent originals. Eight additional programmes allow work with different half-tone and continuous-tone materials which usually requires

REPRODUCTION CAMERA

8.1

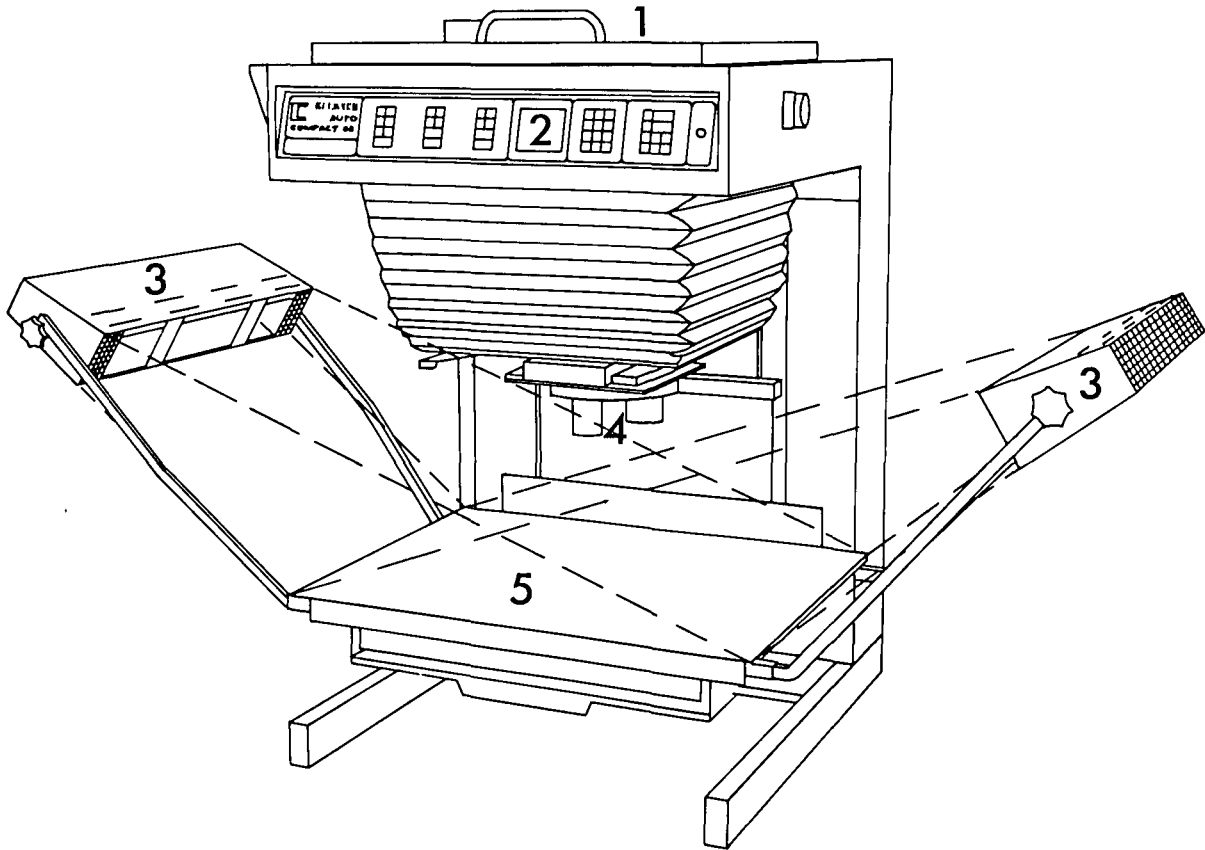

- 1. Vacuum Filmholder
- 2. Operating Panel
- 3. Xenon Copyright Reflectors
- 4. Revolving Lens Holder
- 5. Rise and Fall Vacuum Baseboard with Xenon Light-Source for Originals

more than one exposure. The lighting system consists of 4 KW Klimsch Solarflex V-2422 Xenon lamps housed in floodlamp reflectors on both sides of the camera for reflection work and 4 KW Solartrans Xenon lamps for transmission work. Contrary to many other compact reproduction cameras, however, the exposure itself is controlled by a built-in shutter. Preflash illumination is provided in the bellows itself.

It should be noticed that the part containing the film holder is an integrated part of the whole camera construction. Thus, apart from the lens holder/bellows, only the vacuum baseboard which holds the original is moving. In order to maintain the optimal angle of incidence, the lamps consequently move together with the baseboard. Further automation of the camera is possible by using an on-line densitometer, feeding the microprocessor with the necessary data with respect to density range etc. of the original to be reproduced. Total power consumption is 5.3 KW.

The reproduction camera is used for:

- 1) Reproduction of line originals (drawings, tables etc.) on paper or film,
- 2) Reproduction of multicolour or b/w continuous-tone originals (drawings, photos), as continuous-tone or half-tone (Raster) copies, on paper or film,
- 3) Simple photography of two-dimensional objects in cases where standard reproduction illumination is considered adequate.

The copies may serve as intermediate films or prints for composing work (e.g. production of photos of celestial objects with superposed radio maps, or combination of line films for printed-circuit work). More often, however, the prints or films are used directly, for instance illustrations in publications or as transparencies for overhead projection.

A number of different photographic materials are used for these assignments. Nevertheless, most jobs are done with materials utilizing the controlled diffusion transfer process, which provides a quick way of obtaining line or half-tone copies of a very high quality.

Agfa-Gevaert and Kodak both supply a comprehensive range of products based on diffusion transfer. SAL uses the Copyproof materials made by Agfa-Gevaert (similar products "PMT", are available from Kodak). In the controlled diffusion transfer process, the negative image (usually in a paper-negative, exposed in the reproduction camera) and the positive image (in a receiving paper, insensitive to light) are developed simultaneously while being pressed together after immersion into an activator or developer.

The developer/activator contains a silver halide solvent which dissolves unexposed (hence undeveloped) silver halides of the negative and carries it into the adjacent gelatine layer of the receiving paper. Here the silver nuclei act as reduction centres for silver halides contained in the developer. After a contact time of 15-60 seconds, the emulsions are stripped apart, and the receiving material now features a positive copy of the original drawing or photo to which the negative was exposed in the reproduction camera.

Processing takes place in a simple Agfa-Copyproof CP-42 mono-bath processing machine (max. width of acceptance: 42 cm) and the total dry-to-dry processing time is 60-120 seconds, depending on the material used (line or continuous tone, reversal, receiving material). Fix or rinse is not required. However, if archival keeping quality is needed, a short rinse is necessary. Since receiving materials are resin-coated (RC), drying can be done with any drying machine used for drying normal photographic RC-papers.

8.2 Development of B/w Negative Films

Even though the above mentioned method is very useful for many purposes, we still use b/w negatives extensively at the SAL.

After exposure in a camera or at the enlarger, the development of a b/w negative film has a very important influence on its properties, e.g. the graininess and the contrast as well as the density.

There are basically four possibilities for the development of negative films:

- 1) Automatic development in a processing machine
- 2) Manual development in tanks (10 l)
- 3) Manual development in a small tank (0.5 - 2 l), only for small quantities of film) using reels.
- 4) Manual development in trays (only for sheet films)

By the second and third methods, it is possible to develop films of all formats up to 8x10" (20x25 cm). In the fourth, one can develop sheet films of any size. The methods employ different types of agitation and need different development times. In the machine, the agitation of the liquids is done by automatic circulation (electrical pumps), in the small tank it is necessary to employ periodical tilting, etc.

At the SAL, the development of negative films takes place in Rooms 3 and 4 which are kept at a constant temperature ($21 \pm 1^\circ\text{C}$). It is possible to regulate the temperature of the baths by placing the tanks and trays in a thermostatically regulated water bath.

It is often argued that the application of automated machine processing of b/w prints at labs with limited production does not bring any major advantages as compared to manual dish processing. Thus, so the argument, the investment is difficult to justify. Apart from the convenience, however, we find that a processing machine is a valuable asset in the daily struggle to maintain the required cleanliness in the labs.

Our machine is a Kodak RP X-Omat. Originally designed for processing of X-ray materials, it has proved to be very useful for processing of standard RC printing papers. The maximum width of acceptance is 40 cm and the dry-to-dry processing time is ~ 130 s. The machine has three tanks: 1) developer; 2) fix; and 3) rinse. Tank capacity is 5 l with replenishment tank capacity of 30 l. Replenishment is triggered automatically by the entrance detector crossover and the quantity (ml/m^2) is preset.

Temperature of developer and fix is maintained by heat exchangers and circulation pumps. The water temperature is regulated by external equipment and the water consumption is 6 l/min. A low weight of racks and crossovers permit easy removal for cleaning. Finally, exhaust fumes are removed from the machine through a ventilator and a tube leading to the outside.

For manual development a system of six tanks each containing 10 litres is normally employed. Only in exceptional cases (special developers or developing techniques) do we use the small tanks or trays. The six tanks contain developer, stop bath, fixing bath I, fixing bath II, washing and photo-flo. As developer we use either KODAK D-76 or KODAK Microdol X. The D-76 is especially useful when the highest resolution is desired and the Microdol gives the finest grain, but has some loss of definition. The development times are as indicated by the manufacturers. The stop bath (30 seconds) is bought off the shelf or prepared by diluting acetic acid. The two fixing baths assure a good archival quality of the films; normally the fixing time is 5-10 minutes. The washing takes at least 20 min., so that the silver thiosulphates and other chemicals are completely removed. Finally, the film negatives are dried in a closed, heated drying cabinet before they are used for further reproduction.

8.3 B/w Enlargement

From the negatives we make enlargements to bring the final picture to the desired size. Enlargements can be made on film and paper, depending on the use of the final product.

At the SAL, we use a DURST Laborator 184 enlarger (Fig. 2.2) with nine exchangeable condensers, objectives (lenses) with focal lengths from 28 mm to 360 mm, a vacuum baseboard and motor driven motions of the enlarger head, the focussing and the baseboard. The frames (negative carriers) take up to 24 x 24 cm formats and the enlargement factor is from 0.17 - 33 x (50 mm focal length) or 60 x (28 mm length). The optical system gives a uniform illumination of the entire negative. This is achieved by

by inserting appropriate condensers in the light path. Double condensers are used to achieve the best possible uniformity, in particular when dealing with large formats. Similarly, a large variety of special lenses (mainly from Zeiss) allows optimization for any picture reproduction in terms of geometric fidelity and uniformity of illumination. It is important that the negative remains flat; this is obtained by placing it between two glass plates, the upper of which is of the anti-Newton type. The planity of the copying material (paper or film) is taken care of by the vacuum platen.

The main problem is that the negative will often have a very large contrast (1:2000 or more), but that the paper normally can only reproduce 1:50. Thus, it is necessary to direct the reproduction process so that it will optimize the reproduction of those features which are of particular importance to the user (see also Section 9). By choosing the appropriate paper (glossy or mat, gradation), it is possible to improve the result. Various techniques are available to improve the contrast in different images, for instance by dodging part of the image during exposure.

RC paper is extensively used at the SAL. It is normally developed in the above mentioned KODAK RP X-OMAT Processor (total processing time 2 1/2 minutes), which greatly speeds up all printing tasks. It is particularly useful to be able to evaluate test exposures quickly, so that the correct parameters can be determined without excessive loss of time.

Sometimes the paper is developed in a tray in order to achieve special effects.

The enlarger head can be tilted 90° for horizontal projection. Thus extreme enlargement factors can be reached, for instance to make murals. For this purpose, the enlarger is placed on rails (Fig. 2.3) and a large metal plate is fixed to the wall opposite the enlarger. Magnets keep the roll paper in the correct position during exposure. Murals are processed in long trays put up for this purpose in the adjacent dark room (Room 4).

DIFFUSE LIGHT CONTACT PRINTER

9.1

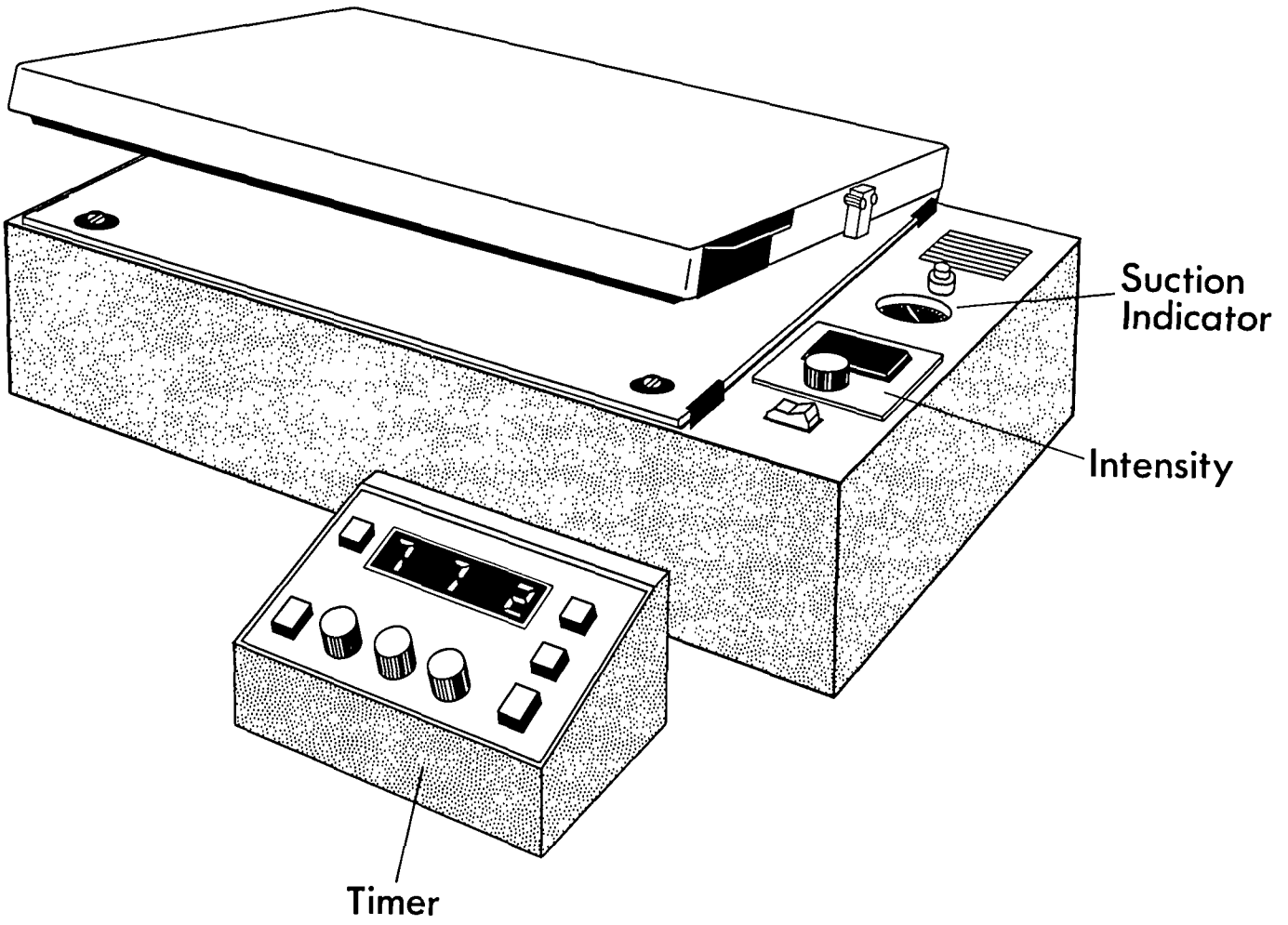

9. Advanced B/w Copying

9.1 Diffuse Light Contact Printer

Used for special copying techniques, the diffuse-light contact printer (Fig. 9.1) has proven to be a versatile and important instrument. The printer, an Agfa-Gevaert SV-400 model, is a table-model printer and was originally designed for making offset printing plates. For large Schmidt plates, we use a (big) Klimsch Vakuprint contact printer, but the copying principle is the same. The printer features a diffuse, uniform illumination and has a vacuum lid. The exposure is varied either by changing the intensity of illumination or the exposure time, by means of an attached DURST DIGITIM 2000 timer. The printer is mainly used for two purposes:

1. Printing spectroscopic plates of high density range by employing the masking technique (see Section 9.2), and
2. Obtaining "surface-prints" of spectroscopic plates in order to extract information about very faint objects not printable with standard printing techniques. This method is usually known as the image amplification technique (see Section 9.3).

The contact printer is also used for general work, such as proof-printing and preflashing film and printing paper.

Spectroscopic plates with a high density range (ΔD) are difficult to print. The problem arises because the dynamic range of the copy material is much smaller than the density range of the original plates. This is the case with both film and glass copies, and it is even more pronounced with prints on paper. The dynamic range of available printing paper does not exceed $\Delta D \sim 1.5$ (depending of course on the printing equipment, e.g. diffuse light, condensor light or point light), whereas spectroscopic plates may have density ranges approaching $\Delta D = 4$.

Standard printing methods thus lead to a significant "cut-off", mostly of high densities. The copy reproduces the high density

area of the original with no discernable separation, hence much information is lost in the copying stage.

9.2 Unsharp Masking

One solution to this problem obviously lies in the method of unsharp masking^{4,5}. Masking originates from the graphic arts industry, and the major manufacturers of graphic arts film all offer special masking film. Unfortunately, these films are designed for bridging considerably smaller "density-gaps" than what is normal on astronomical plates. This means that we cannot use these films for our purpose. Furthermore, most masking films are panchromatic sensitized, making them less convenient for astronomical use. A good alternative, however, is the unsensitized (blue-sensitive) Kodak 4127 Commercial Film, which has become a standard film in astronomical darkrooms.

The basic idea of masking is that by introducing a photographic mask in the copying stage, the tonal range of the original plate is suppressed in such a way that the lower and upper parts of the characteristic curve remain (almost) untouched, whereas the "mid-densities" (placed on the steep, "straight" part of the curve) with their good tonal separation are compressed (Fig. 9.2).

First, the minimum and maximum density of the original plate is measured with a transmission densitometer (ANSI Diffuse). The information about ΔD and D_{\max} is used for determining the necessary characteristics of the mask. The back of the original plate is then fitted with fiduciary markings and the plate is placed emulsion down on the contact printer. Diffuse light is used to achieve the necessary grade of unsharpness of the mask. In addition, because of the Callier effect, the penetrating properties of diffuse light at high densities is better than that of point light.

The masking film is now exposed in contact with the back of the original plate. Exposure and subsequent development is chosen so that the density range of the mask is somewhat lower than that of

THE PRINCIPLE OF MASKING

9.2

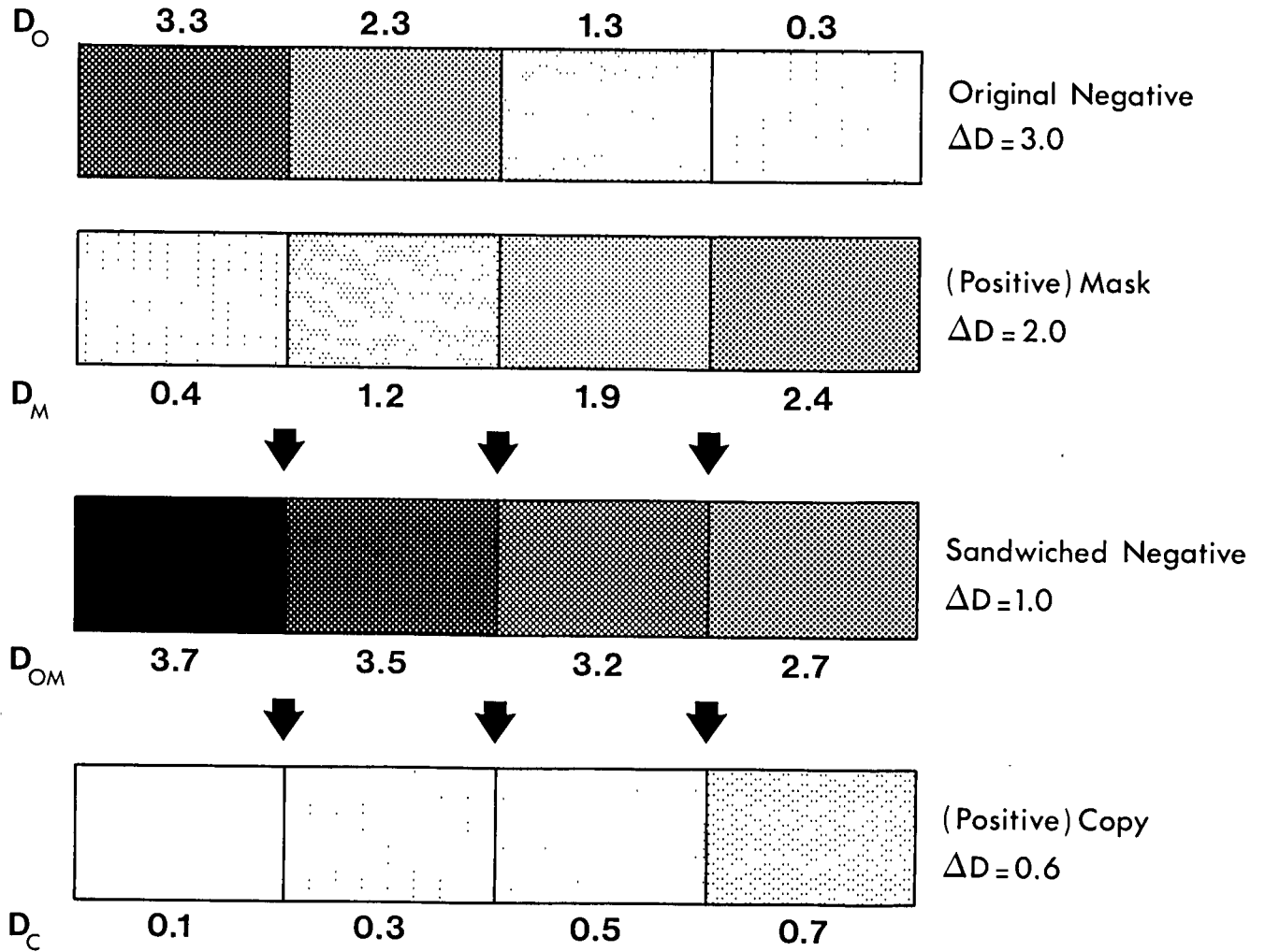

The principle of masking is illustrated by showing 4 densities in an original plate. The maximum density to be reproduced is 3.3, the minimum density 0.3. The non-linear response of the masking film is evident. The sandwiched negative plate/positive mask features a high overall density, but with a greatly reduced contrast.

the original (a D_{\max} of ≤ 1 is a useful starting point).

The copy film - or mask - is exposed in contact with the back of the original plate and renders an unsharp, positive reproduction with a reduced contrast. The fact that the mask is unsharp not only facilitates correct repositioning on the original, but also assures that small objects remain virtually untouched. Thus the mask will have a strong influence on a nebula, but not (or at least much less) on surrounding stars. On the other hand, it tends to enhance the edges of the objects concerned, e.g. filamentary structures. When the masking film is dry, it is repositioned on the back side of the original plate with the help of the fiduciary markings. We now have a so-called "sandwich" consisting of a high contrast original and a low contrast positive copy, i.e. an image with a very high overall density but with a reduced density range.

The "sandwich" is now turned around, i.e. emulsion up, and another copy film is exposed in the contact printer and processed in the usual way. It will now contain all the details, i.e. the information of the original plate, except for the reduction density range that makes the picture printable.

A point not to be overlooked is that the non-linear response of the masking film is instrumental in retaining a good reproduction of faint objects (near the lower end - the toe - of the characteristic curve) of the original. Important parameters are therefore:

1. The length and slope of the characteristic curve (D - $\log E$ curve) of the original plate and masking film (to be influenced by exposure and development), and
2. The extent of unsharpness of the mask (to be influenced by the thickness and optical quality of the spacer between the emulsion and the masking film).

9.3 Photographic Amplification

Of great interest to many astronomers is the image amplification technique^{5,6}. This method is used to enhance structures and objects of low surface brightness, for instance such objects which are found in typical class II detection situations (low $S:N_{in}$). Weak exposures originating from faint objects are found in the uppermost layers of the photographic emulsion. Unfortunately, the density of the photographic plate is not exclusively determined by the exposure (i.e. $S:N_{in}$), but also by the processing in which the development plays the most important, but by far not the only role. The developer tends to react with unexposed as well as exposed silver halides, causing an overall density (chemical fog). Furthermore, the carrier of the emulsion often has a density of its own. This is termed the "base density", which together with the chemical fog makes the "gross fog". The gross fog obscures the weakest images of faint objects, because the densities that make up the faint images cannot visually be separated from the fog density.

In terms of photographic theory, these faint exposures are found in the area between the exposure threshold and the "speed point" of the emulsion in question. This may seem a somewhat confusing statement, inasmuch as the exposure threshold and the speed point are normally considered identical. According to ISO specifications (ISO/R-6 1954, revised 1962), the speed of an emulsion is determined by the exposure (E) in Lux sec required to give a shadow density of 0.1 D above fog. The weak exposures which we seek to enhance may lie below this value. However, the silver halides which produce the fog are generally spread throughout the emulsion layer. This means that a separation between the weak exposures and the fog can be achieved by the printing method known as image amplification.

What concerns plates exposed to the sky background it is often found that the faintest objects are not printable in the traditional way, because the density difference between the background and the object is too small. With the image amplification technique, however, this problem can also be

THE PRINCIPLE OF IMAGE AMPLIFICATION

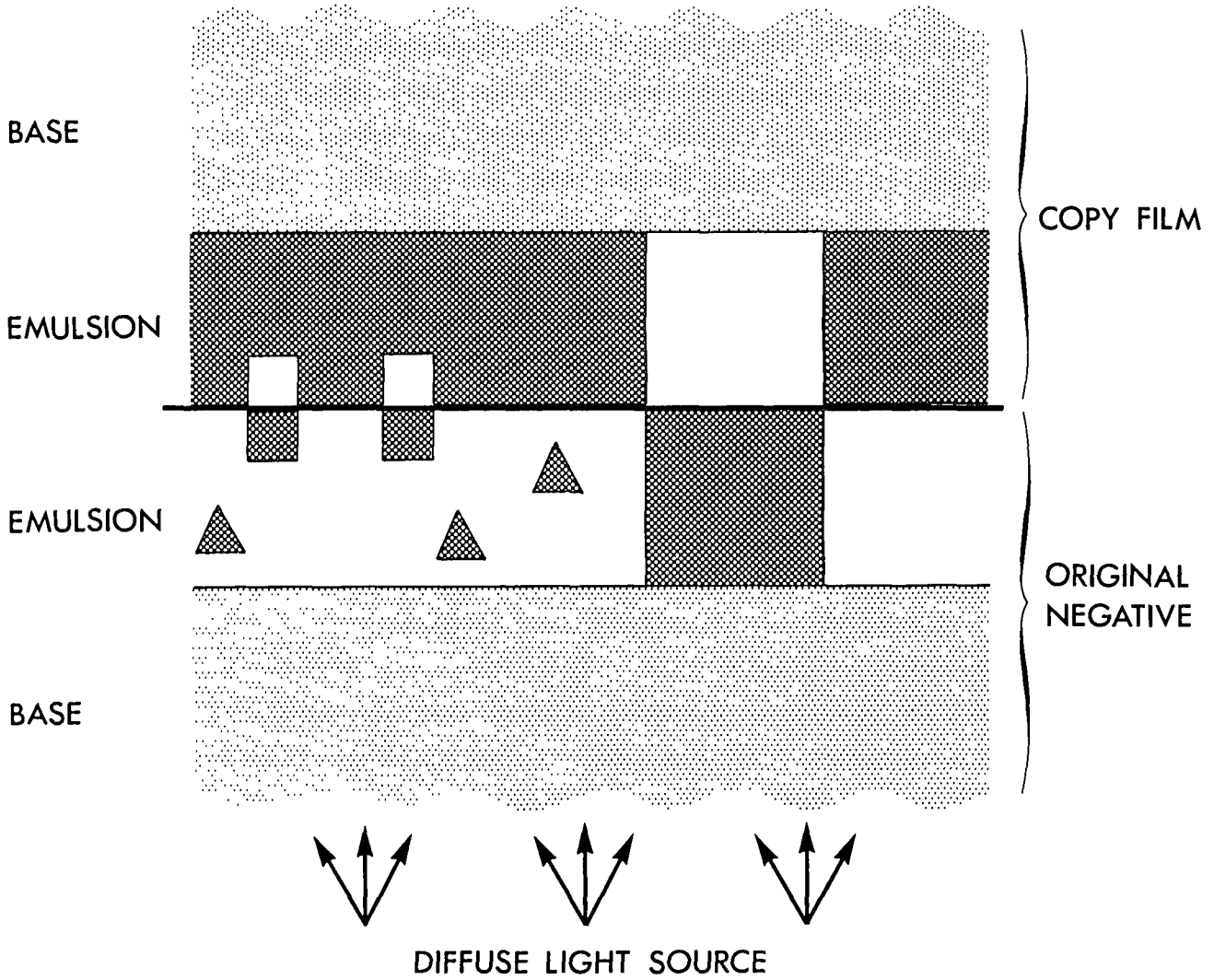

By using a diffuse light source, weak exposures (small squares) in the original plate are reproduced, whereas the fog (triangles) is reduced.

overcome (Fig. 9.3).

By means of the diffuse-light contact printer, a copy of the original plate is made on high contrast film. The diffuse light serves to suppress the gross density, insofar as this is caused by silver in the lower parts of the emulsion layer, but without losing the faint exposures in the top of the emulsion layer. These faint features thus become visible and printable. Since it only gives a sharp reproduction of the emulsion surface, the method leads to a general enhancement of the grain in the upper layer of the emulsion. The contrast enhancement makes it difficult to distinguish density differences, (e.g. faint objects superimposed on the halo of an elliptical galaxy). This is partly due to the low dynamic range of the high contrast copy film, partly because of light scatter in the copy emulsion and partly (see above) due to an enhancement of the remaining noise (the surface grain).

A further improvement can be achieved by combining amplified derivatives of several plates of the same object(s). Each derivative will contain amplified images of objects (signal), but also feature an enhanced, randomly distributed granular structure as well as plate defects (noise). With the integrated printing (i.e. the combination of several copy films), the noise partly cancels out, whereas the objects become further enhanced. The result is a high contrast print with a very good reproduction of faint images, but with a significant noise reduction (i.e. better spatial resolution) as compared to a single, enhanced derivative.

An important point in connection with the amplification technique is that the sky background (in the copy film) must be kept at a fairly low level. In other words, the ΔD of the copy films has to be low ($\Delta D = 0.5 - 0.6$ is considered a maximum). Overexposure (leading to increased ΔD) will degrade or inhibit reproduction of the faint images, either in the copy film itself or in the subsequent paper print, because of light scatter in the copy emulsion(s).

9.4 Superposition Frames

Integrated printing as well as tri-colour printing (see Section 12) requires the use of a superposition frame. Two types of frames are frequently used.

The first one is an aluminium frame with a glass plate (Fig. 9.4). At two edges, the frame is fitted with Kodak Registration Hole Punching devices. The frame is placed on a light table, and the films viewed in transparent light. The superpositioning (only two films at a time) is checked by inspecting the films under a zoom microscope, which moves freely over the superposition frame itself, and which covers the whole area. When the films match, registration holes are punched at two edges (e.g. N and E). In case of colour work, the (B) and (V) films are first superimposed, followed by the (V) and (R) derivatives, which will be punched at the opposite edges. The (B) film thus has registration holes in N and E, the (R) in S and W, and the (V) has holes at all edges (N,E,S,W).

The films can now be separated and printed individually in a contact printer, the correct position of the films being secured by registration pins mounted on the platen of the contact printer.

The other type of frame can be used in connection with enlargements of small objects (using enlarger-printing rather than contact-printing). The frame, of aluminium or wood, resembles an enlarging easel, but features a light-tight hinged lid instead of easel masks (Fig. 9.4). Before exposing the first part-image, a sheet of b/w paper is glued onto the lid and exposed. After exposure, the paper is removed for processing, and the dry print is again fixed to the lid. The print now acts as a "superposition reference". The copy material used for the final copy is placed under the lid. Every time a new film has to be superimposed, this is done with the lid closed and by moving the frame until the projected (new) image and the printed (old) image on the lid match. The lid is then opened, and the copy material can now be

SUPERPOSITION FRAMES

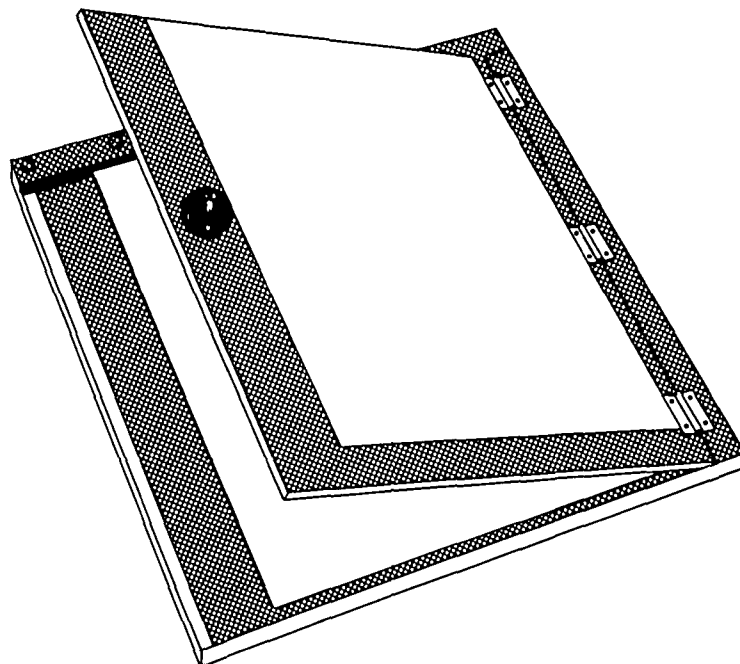
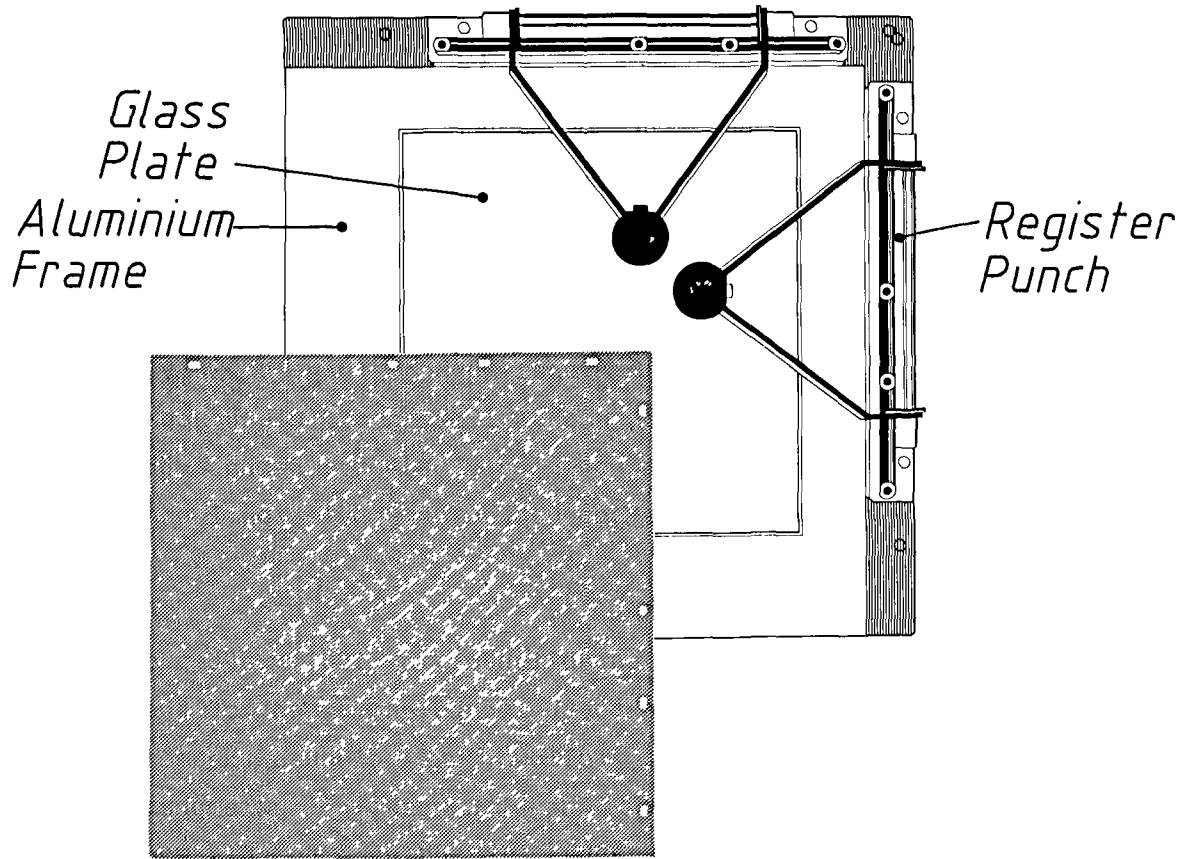

exposed. After completion of all the part-exposures, the copy material can be removed for processing.

10. Colour Work

At the time of the move from Geneva to Munich, it was decided to equip the SAL with a colour laboratory. There were several reasons for this, but the most important was that it was felt that it would be important to investigate in detail the possibilities of producing colour pictures from b/w sky photographs.

It has been demonstrated by several authors (e.g. J. Wray and D. Malin^{7,8}) that colour photographs allow an efficient separation of different types of astronomical objects. Perhaps the most convincing example is the separation of Population I and II in spiral galaxies.

The ESO colour lab was established in 1981, after serious consideration had been given to the scope and extent of the tasks to be performed. In what follows, we discuss the means and methods employed at the SAL with particular emphasis on astronomical colour photography. In addition to this work, the lab also produces publicity prints of various types for ESO. The possibility of exercising in-house control over these types of work has turned out to be extremely useful and, in view of the large amount of material produced, substantial savings have been made.

10.1 Equipment

The colour enlarger is an Italian-made Durst L-1800 Repro-Laborator, fitted with a Durst CLS-2000 Colour Head (Fig. 10.1). The colour head encloses a 2000 W constant colour temperature tungsten halogen lamp and light mixing boxes with diffusers to provide a uniform, diffuse printing light. The exposure is preset on a timer and is controlled by a built-in shutter. The use of a shutter in connection with preheating of the light source ensures a high repeatability accuracy and

COLOUR ENLARGER

10.1

Durst Color Laborator 1800+CLS 2000

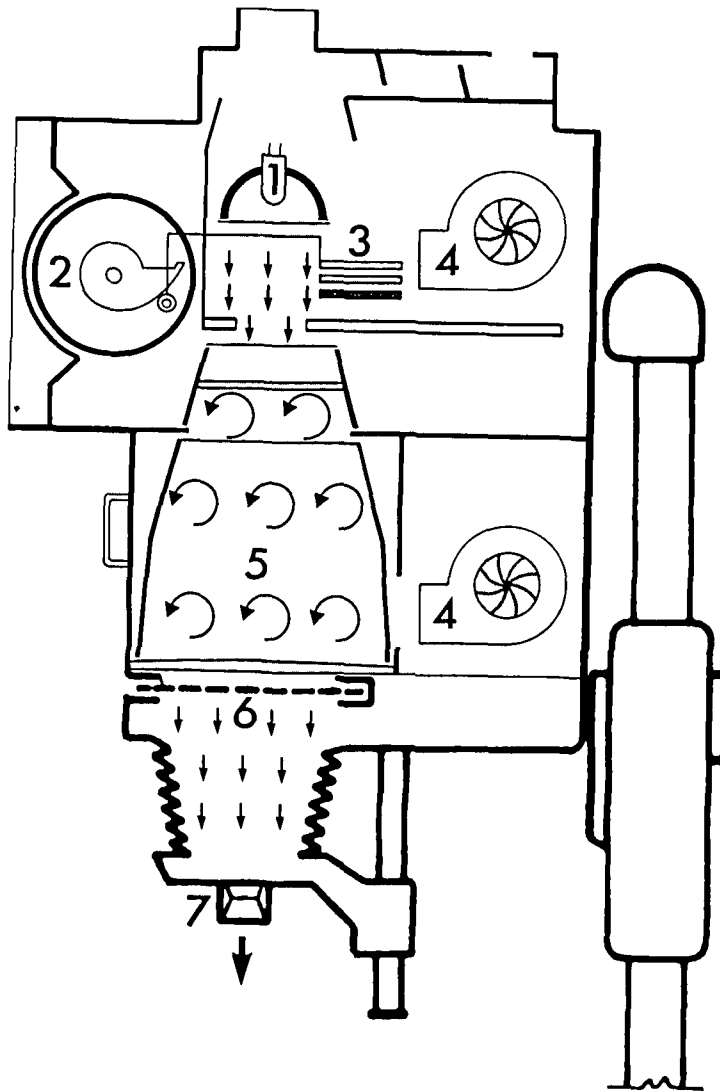

1. Halogenlamp 2000 W
2. Illuminated Filter Dials
3. Dichroic Colour Printing Filters in Yellow, Magenta and Cyan
4. Cooling Fans
5. Light Mixing Box
6. Negative Carrier
7. Lens

constant intensity, even at very short exposure times (e.g. ≤ 1 second). The colour head also features dichroic filters of variable intensity in the primary subtractive colours, Yellow, Magenta and Cyan as well as neutral density (grey) filters (maximum density ND 60). The maximum density of colour filters is 170Y, 170M and 130C (equals ~ 255 cc values in Y and M, ~ 195 cc values in C). The negative carrier incorporates register pins for composing work, and can accommodate originals up to 25x25 cm.

The enlarger is in principle designed for use with fairly large originals (negatives or transparencies) but interchangeable light boxes allow the use of smaller formats (down to 35 mm). The upper section of the enlarger can be tilted 90° for horizontal projection. However, the limited space available in this darkroom does not allow the possibility and the enlarger is used exclusively for vertical projection on a vacuum base board. The base board features retractable register pins and accommodates printing material up to 76x102 cm format. The maximum format that is handled under normal conditions is 50x60 cm. In addition the base board incorporates a register punch at the leading edge. All movements of the enlarger (including focusing, but excluding filter settings) are motorized and are usually controlled from an illuminated panel located under the projection base or "remotely" by a handle (basic functions only). Connected to the enlarger is a voltage stabilizer which also permits switching to reduced intensity (1000 W).

Safety light in the darkroom is provided by a single 15 W sodium vapour lamp with a spectral emission suitable for colour printing materials.

The colour processing machine is manufactured in W. Germany by Autopan and designed for the Ciba P-3 process used for processing of Cibachrome CPS and CRC papers and CTD film (Fig. 10.2). The machine is designated Type 60-40C, indicating a width of acceptance of 60 cm for paper or film. Being a roller-transport type machine, the processing speed is 40 cm/min, giving a dry-to-dry processing time of 23 min. The tanks each contain 28 l of liquids with a replenisher tank capacity of 50 l. Water

COLOUR PROCESSING MACHINE FOR CIBA P-3

Autopan Contimat 60-40 C Type 259

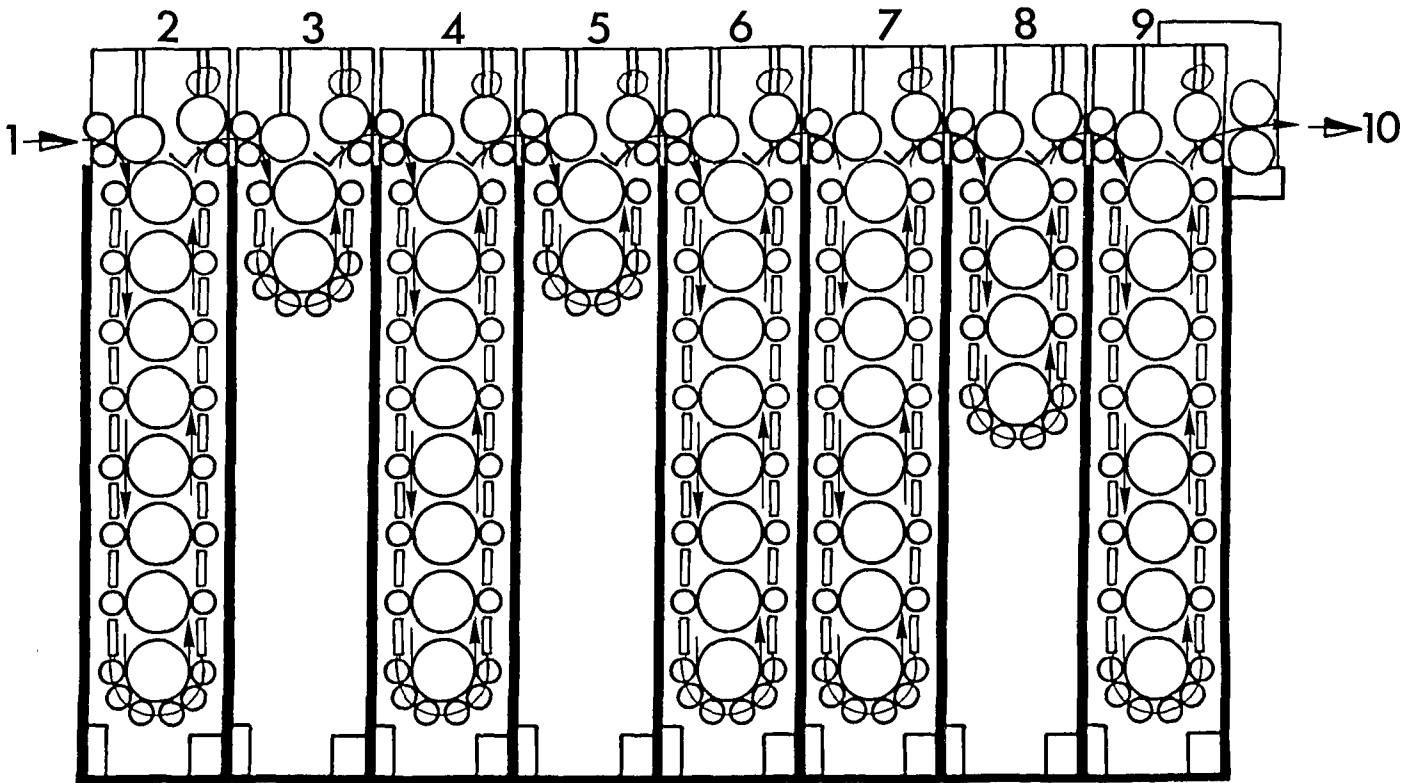

- 1. Material Entrance
- 2. Developer
- 3. Rinse
- 4. Bleach
- 5. Rinse
- 6. Fix. 1
- 7. Fix. 2
- 8. Rinse
- 9. Rinse
- 10. Exit to drying section

consumption is 9 l/min. Thus the machine is a medium-size, medium capacity machine, well suited for a colour-lab with low-to-medium and fluctuating output.

As foreseen for the P-3 process, the machine contains tanks for 1) developer, 2) rinse, 3) bleach, 4) rinse, 5) fix, 6) fix, 7) rinse and 8) rinse followed by a drying section. In compliance with basic Ciba recommendations^{9,10}, the two intermediate washes (tank 2 and 4) are connected to a forward cascade. Fresh water flows in wash tank 2), and the overflow is led to wash tank 4), the overflow of which goes to the drain. This system effectively ensures a neutralization of residual bleach (pH-value ≤ 1.0) as the water in tank 4) has previously been used to wash out residual developer (working pH = 9.70) and consequently has a relatively high pH value. Similarly, the washing tanks 8) and 7) are connected to a countercurrent cascade. The cascade system effectively reduces water consumption. Tanks are fitted with heat exchangers (except for water tanks) and circulation pumps with a capacity of 22 l/min. Water temperature is maintained by external installations. Replenishment of chemicals at a preset rate (ml/m² of emulsion) is automatically initiated by IR-sensors at the feed tray. These sensors also trigger the switch-off of the machine (and water) after 23 min of running time, thus limiting the water and power consumption (6.3 kW).

The machine incorporates a timer that automatically switches on and off the heat exchangers at preset times. This means that the machine is in a standby mode, e.g. from 08.00-18.00 on working days (but disconnected over weekends), thus relieving the operator of waiting during the hour-long warm-up period. He can therefore start working with the machine immediately after refilling the water tanks, which must be emptied every night, and checking the general conditions of the chemicals.

For cleaning of the machine, racks and crossovers can be removed from the tanks by means of a hoist. Cleaning as well as maintenance requires adequate access to the machine from three sides. The machine is therefore placed in the middle of the day-light room (see Section 12) with the feed tray extending into

the darkroom. Heating of chemicals and developer temperature fluctuations can be monitored from a panel mounted over the feed tray. Since they are extremely toxic and corrosive, the handling of P-3 chemicals requires certain safety procedures: The working strength of the bleach replenisher contains 6.1% sulphuric acid and SO_2 may be released if developer and bleaches are mixed. The machine is therefore fitted with an exhaust system that removes all fumes from the machine itself in order to prevent serious health hazards.

10.2 Procedures

The subtractive printing technique is usually employed in connection with "normal" colour printing, i.e. the production of several of copies (prints on paper or duplicates on film) from colour originals. The virtue of subtractive printing is that it requires only **one** exposure, through filters of one or two of the primary, subtractive colours. This corrects colour casts due to unavoidable variations of the printing procedure as well as intrinsic colour casts of the printing material itself (subject to changes, e.g. during storage).

Among the different colour materials/processes available on the market, ESO has selected the Cibachrome P-3 process. A similar product, designated Cibachrome A-II, has recently been introduced for the benefit of users with a more modest need for colour pictures. Contrary to the P-3 product, which requires a processing machine, the A-II paper can be processed in a small drum-type processing tank, which, however, only accommodates one print at a time. Most available colour materials are often described as "chromogenic", implying that the dyes which form the image are produced by a chemical reaction between the oxydizing product of the developer and colourless, so-called colour-couplers, embedded in the photographic emulsion. Hence the dyes are formed during processing. Limitations imposed by the chromogenic method includes relatively poor sharpness, because of light scatter in the (rather thick) emulsion and the formation of dyes, which fade rather quickly when they are subjected to ordinary daylight (or rather UV-light).

Unlike chromogenic materials, the Cibachrome process is a colour bleaching process, meaning that all dyes are present in the emulsion right from the beginning. The image is formed simply by bleaching out excess dyes. The presence of dyes in the emulsion reduces the light scatter in and between the emulsion layers and the resolution is significantly improved. Furthermore it is possible to use dyes with greater stability against daylight.

Good keeping properties of chemicals, superior sharpness and colour keeping quality were the main reasons for selecting the Cibachrome materials. A major inconvenience in the handling is that the chemicals must be treated with the utmost caution, as they are extremely toxic and corrosive. The price for Cibachrome materials is somewhat higher than comparable chromogenic materials, which however is partly offset by better keeping properties of the chemicals (a point not to be overlooked at labs with fluctuating production).

Being a colour bleaching process, the material is of course a reversal material, requiring transparencies as originals. We generally consider this an advantage, since it is obviously easier to appraise colour balance on a positive material, than on a negative picture. This also makes the acquisition of an (expensive) colour analyzer unnecessary.

The most important aspect of working with transparencies as master material, however, is that we very often use colour composites as originals. Our composites are in fact generated colour images (of celestial objects), made by superimposing b/w positive derivatives of original (b/w) astronomical plates, obtained in different pass-bands.

A IIa-0 plate, for instance, exposed behind a GG-385 filter, is the equivalent of a standard, blue colour-separation film. Similarly, other combinations of spectroscopic plates and filters can be considered as colour separations, too. Real colour images can therefore be created by superimposing these ("master") films and subsequently expose each film through the appropriate colour filters onto a single colour emulsion. Original plates obtained

in B-V-R can be combined to form a true-colour image, whereas plates in other passbands may be combined to form a false-colour image - a very useful tool for fast detection of objects with emission excess in a particular wavelength. This technique requires several (usually three) subsequent exposures, which means that the aforementioned subtractive printing method does not suit this type of work. Fortunately, the additive printing method comes to rescue. This method dates back to the dawn of colour photography. It was in fact used by Maxwell as early as 1861 to create and show a colour transparency. It requires three separate exposures through filters of the three primary, additive filters, Blue (B), Green (G) and Red (R). The colour balance is determined by changing the relative exposures, whereas the brightness is influenced by the total amount of exposure.

Generally considered slow and inconvenient, the method has largely been superseded by the subtractive method in conventional photography. It will be remembered that subtractive printing only requires one exposure, which determines the brightness, whereas the colour balance is controlled by the combination and density of filters applied.

Yet, the fact that additive copying requires three exposures proves very useful for us, because it allows us to print different images through different filters, thus creating a colour picture. The characteristics of the original plates are important factors. General requirements when combining several plates are: same field centres on the sky, similar plate resolution and approx. equal limiting magnitudes. B-V-R plates have different characteristic curves (exposure vs. density), but since original plates are negative and we need positive (copy) films, we can adjust the slope of the individual curves to suit our requirements when we make the positive b/w copy films, e.g. by preflashing. Failing to adjust the curves may lead to uncontrollable colour casts affecting either the sky background (and objects of low surface brightness) and/or bright objects. The intermediate copy films are usually made by contactprinting of the original plates.

Apart from individually adjusting the images, this stage also permits a general adjustment (e.g. contrast enhancement to retain faint objects) in order to achieve a density range suitable for the colour material. The dry b/w positive films are aligned (with the help of the superposition frame described in Section 9.4), registration holes are punched, the films are separated and subsequently exposed in contact and through the appropriate B,G and R filters (Wratten Nos. 98(B), 99(G) and 70(R)) onto a colour duplicating film (Kodak Ektachrome Duplicating Film 6121).

After processing we now have a colour transparency (usually 25x25 cm) which now acts as a master, from which a multiple of copies can be printed, using the fast, subtractive printing method.

The master transparency is produced by contact copying, using a Klimsch Vakuprint VT-111 contact printer with a point-light source, a filter turret and registration pins to keep the b/w films and the colour film in the right position. The production of prints from the master transparency itself is done with our colour enlarger and the exposed Cibachrome material is processed in the colour processing machine (cf. Section 10.1). The colour balance of the master transparency is usually determined by assessing the colour (cast) of the calibration step wedge usually imprinted on the original plates. This step wedge acts as a useful reference through all process stages. In addition, the colour of the sky background is a useful source of reference. It is normally the intention (i.e. in case of true colour images) to achieve an almost optimal colour rendition in the master, hence minimizing the need to apply correction measures during the final printing phase.

Colour balance, contrast, effective speed and colour rendition in the final printing stage (the one requiring an enlarger) is controlled by monitoring factory-exposed test strips developed in our processing machine and measured with a MACBETH RD-519 reflection densitometer (Status D densitometry). This provides us with useful information about the current condition of the chemicals and other processing machine related variables.

Assessment of the colour balance of the final print is done by visual inspection of the picture illuminated by a light source of constant colour composition and intensity. We use a MACBETH Prooflite PLD overhead luminaire, which gives an even, diffuse illumination with a colour temperature of 5000 K. Similarly, the master transparencies are viewed on a MACBETH PLT 516 Prooflite light box, with a uniform light of 5000 K.

This type of illumination was selected because it complies with the ANSI Standard for colour appraisal of copies in graphic arts, and the consistency and spectral composition makes it possible to perform colour inspection and colour evaluation with more uniform results than is possible under the varying conditions of natural daylight.

The method of recreating colour images of deep-sky objects from b/w original plates (employing the tri-colour printing), may seem troublesome, but it is generally considered preferable to the use of conventional colour film.

A substantial low intensity reciprocity failure (LIRF) of conventional colour film seriously inhibits the long exposures required in astronomical photography. In addition, the LIRF characteristics of each layer of the colour emulsion differ leading to unremovable colour casts similar to those mentioned above in connection with the adjustment of density curves of b/w colour separation film. Ordinary colour film also has sensitivity "gaps" at certain wavelengths. Thus, we prefer to use b/w plates for colour photography at ESO to avoid these problems.

11. Cleanliness

Cleanliness is a very important aspect of the work in the SAL. Especially in the Atlas Section it is of paramount importance that the copies are as similar as possible to the originals. In practice, it is of course never possible to avoid completely loss of information in the copying process, but experience has shown that dust problems can more or less be eliminated by taking efficient preventive measures.

Above all, it is a question of the number of dust particles suspended in the air. They will settle unless they are removed. In the SAL this is first of all done by circulating the air through the aircondition filters, which are able to remove most of the larger particles. However, the labs are contaminated by other sources, in particular by the operators to whom large amounts of dust particles cling. We have therefore concentrated on cleaning areas immediately around the copying machines and the materials before copying takes place. The imprinted shadow of a dust grain can never be removed, but dust grains which settle after the exposure, normally disappear during the processing. We here give some examples of how this is done in practice.

One of the most critical areas is the surface of the contact copying machine which is used for on-film copying (Fig. 5.1). The area is embedded in an air stream from a VITESSE 60 air filter box. The air stream efficiently blows away any dust particles before they settle on the surface of the intermediate positive plates which are being copied. Furthermore, the entire room is cleaned by a FILTAIR 200 filter unit. This device has a rotating filter which sucks the air in, lets it pass through several filters and effectively eliminates all particles larger than 0.5 μm .

The lighttrap floors and entrances to all darkrooms are covered with an adhesive carpet which removes particles from the soles of the operator's shoes. The operator wears a nylon coat that attracts dust, which would otherwise contaminate the plates and films.

Other sources of dust, like cardboard boxes and pieces of cloth are not allowed in the room. The preparation of processing liquids is done outside the room.

The walls are painted with latex paint, and all piping is of PVC with a smooth surface. Similarly, the floor is covered with tiles, so that all surfaces are easy to clean.

Table II

Dust at SAL on 13 October 1983
Rooms are indicated in Figure 2.1

Place	Particles $\geq 0.5 \mu\text{m}/\text{ft}^3$
Corridor outside Room 5	36.000
Corridor outside Room 6	26.000
Lighttrap Rooms 12 and 15	7.500
Lighttrap Rooms 13 and 14	25.000
Room 6	7.500
Room 15	12.000
Room 12	4.000
Clean Air Box in Room 14	100
1 meter from VITESSE 60 in Room 12	2.000

The number of dust particles in the air is regularly measured with a Climet 250 portable particle counter. The air chamber is evacuated and the particle size limit is set to 0.5 μm . The device counts all particles larger than this size in a volume of about 0.1 cubic feet, which is sucked through the chamber during 30 seconds. The measurements are done in different areas and at different times of the day and week. This procedure has allowed us to identify dust sources and to eliminate or at least reduce their influence.

An example of the number of dust particles in the different rooms is given in Table II. We note that the rooms are very clean early in the morning before work commences, due to the prolonged filtering action in the course of the night, and similarly, that the smallest number of particles per volume is measured early Monday morning.

Other dust elimination devices are in use in various places. An air gun which blows away dust from surfaces that cannot be cleaned by direct action has been described in Sections 4 and 5. In order to clean the copying frames in Rooms 12 and 14, a cleaning roller with adhesive is used.

12. Silver Recovery

The SAL uses large quantities of photographic material and silver recovery is an important part of the procedures employed. For instance, the amount of silver recovered is ~ 0.5 grams per atlas film (40x40 cm) and 1 gram per atlas plate (14"x14"). More than 12 kg are recovered every year.

The main advantages of in-house silver recovery are to avoid having to deal with specialized firms and to collect and store large amounts of fixer which are then transported to recovery factories and, not the least, the better economy achieved by being able to sell the recovered silver at the appropriate moment.

The silver recovery circuit at the SAL is somewhat complicated

and is shown on Figure 12.1. It includes on-line silver recovery during the operation of the Versamat 17 processing machine which is used for development of atlas film copies. As seen on the figure, the fixer is circulated through a silver recovery unit (No. 7) and the silver content is kept at a level of 0.5 grams/l. This allows to decrease significantly the amount of regenerating liquid necessary per film (0.12 l instead of 0.33 l necessary at 1.5 grams/l). Furthermore, due to the fact that the silver content is always maintained at a low level, the films are consistently of archival quality, since the fixing is more efficient and the water tanks are less contaminated by used fixer.

One of the main aims of the silver recovery procedure is to assure that the effluent from the SAL conforms with local pollution codes. As can be seen on Figure 12.1, the overflow fixer from the first silver recovery unit (No. 7) is pumped (via pipe No. 12) into the second silver recovery unit (No. 13). This unit also receives used fixer from other areas, notably the on-glass atlas copy production, paper production and colour production. It also works by electrolysis and reduces the silver content from ~ 1 gram/l to less than 30 ppm. The cleaned fixer is collected in a storage tank (No. 14, 200 l). During one week approx. 120 l is received in this tank. It has a pH of ~ 4.5, and it is neutralized (to pH ~ 6.4) by adding soluble caustic soda from a 50% solution during a vigorous agitation in a second storage tank (No. 15). This method is preferable, as compared to the standard method which neutralizes the fixer by means of used developer, since no residual sludge is formed. This sludge frequently leads to a blocked exit and related problems.

After neutralization, the liquid passes through a small cartridge with ~ 200 grams of steel wool. By ion exchange the silver content is lowered from ~ 30 ppm to less than 1 ppm, i.e. below the official maximum value (1 ppm). It is important that the steel wool is visible so that it can be regularly controlled. It must always have a light grey colour; if it becomes brown (rusty)

FIXER CIRCULATION

12.1

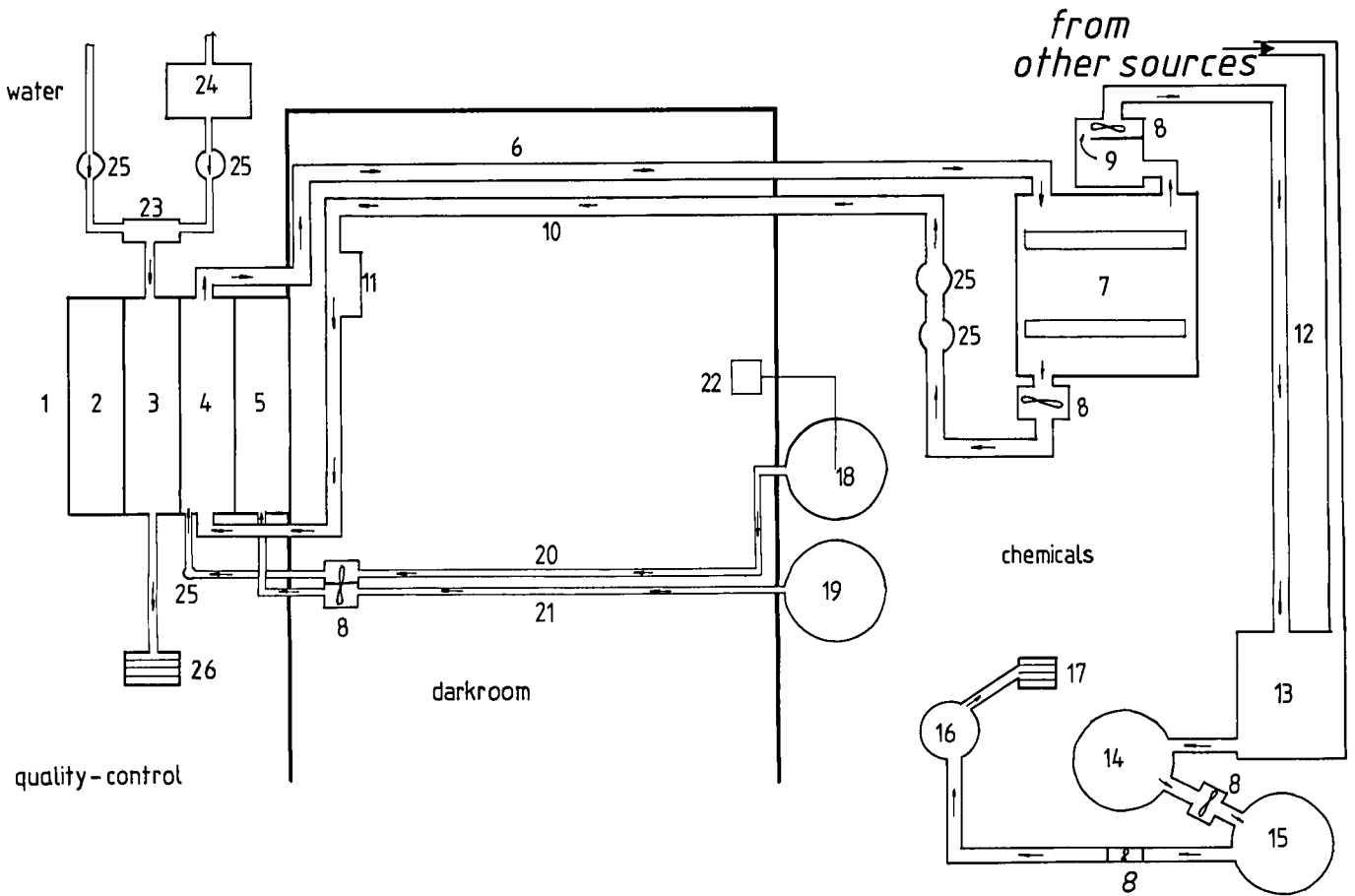

- 1.Kodak versamat
- 2.Dryer
- 3.Water tank
- 4.Fixer tank
- 5.Developer tank
- 6.Fixer-circulation back to versamat
- 7.Silver recovery unit
- 8.Pump
- 9.Overflow tank for fixer
- 10.Fixer-circulation to versamat
- 11.Flow control
- 12.Pipe to second silver recovery unit
- 13.Second silver recovery unit

- 14.Storage tank
- 15.Fixer neutralisation
- 16.Steelwool to retain remaining silver
- 17.Draining
- 18.Fixer replenishment tank
- 19.Developer replenishment tank
- 20.Fixer replenishment pipe to versamat
- 21.Developer replenishment pipe to versamat
- 22.Fixer-level control system
- 23.Water mixer
- 24.Boiler
- 25.Filter cartridge
- 26.Draining

and is shown on Figure 12.1. It includes on-line silver recovery during the operation of the Versamat 17 processing machine which is used for development of atlas film copies. As seen on the figure, the fixer is circulated through a silver recovery unit (No. 7) and the silver content is kept at a level of 0.5 grams/l. This allows to decrease significantly the amount of regenerating liquid necessary per film (0.12 l instead of 0.33 l necessary at 1.5 grams/l). Furthermore, due to the fact that the silver content is always maintained at a low level, the films are consistently of archival quality, since the fixing is more efficient and the water tanks are less contaminated by used fixer.

One of the main aims of the silver recovery procedure is to assure that the effluent from the SAL conforms with local pollution codes. As can be seen on Figure 12.1, the overflow fixer from the first silver recovery unit (No. 7) is pumped (via pipe No. 12) into the second silver recovery unit (No. 13). This unit also receives used fixer from other areas, notably the on-glass atlas copy production, paper production and colour production. It also works by electrolysis and reduces the silver content from ~ 1 gram/l to less than 30 ppm. The cleaned fixer is collected in a storage tank (No. 14, 200 l). During one week approx. 120 l is received in this tank. It has a pH of ~ 4.5, and it is neutralized (to pH ~ 6.4) by adding soluble caustic soda from a 50% solution during a vigorous agitation in a second storage tank (No. 15). This method is preferable, as compared to the standard method which neutralizes the fixer by means of used developer, since no residual sludge is formed. This sludge frequently leads to a blocked exit and related problems.

After neutralization, the liquid passes through a small cartridge with ~ 200 grams of steel wool. By ion exchange the silver content is lowered from ~ 30 ppm to less than 1 ppm, i.e. below the official maximum value (1 ppm). It is important that the steel wool is visible so that it can be regularly controlled. It must always have a light grey colour; if it becomes brown (rusty)

this means that it oxydizes and the ion exchange no longer takes place. This may happen if the flow is too slow or if the stream is stopped for more than 10 minutes. The steel wool must be changed at regular intervals and functions continuously, day and night.

The reason that we do not use commercial steel wool cartridges is that they only work with heavily contaminated fixer. In our case, the concentration is much too low and the industrial cartridges would immediately become oxydated, leading to the release of contaminated effluents.

Regular water probes are made at the exterior of the ESO building to ascertain that the drain remains clean of dangerous chemicals. The main worry is the heavy metals contained in the colour chemicals, f.i. cadmium and chromium. Sofar, satisfactory results have been consistently obtained.

13. Storage

Unexposed photographic materials are stored in Room 7 at a temperature of 16°C. The room is airconditioned and the humidity does not exceed 50%. The room is rather large, since substantial quantities of films and plates are kept in store for the atlas production. Normally, we have photographic material in stock, sufficient for approx. one year's work. In total, Room 7 can store 2.000 plates of different formats, 30.000 16"x16" films and all other materials needed for non-atlas work.

Chemicals are stored in Room 9 at approx. 19°C. In this room we also have a deep-freezer (-30°) in which are kept small amounts of particularly sensitive materials like colour films and paper and spectroscopic plates.

Original Schmidt plates, other plates from the ESO telescopes and atlas plates for the POSS and Southern Sky Surveys are stored in Room 16. There are 48 cupboards in the room and each cupboard has 5 or 6 shelves. Each shelf can carry ~ 100 kg of plates, which

are separated by vertical metal separators, specially conceived for this purpose. All cupboards are painted with an inactive paint which does not attack the emulsions. Tests were made at Kodak to assure that this is indeed the case.

No astronomers or other persons have access to original plates taken for the ESO Atlases. Other original plates can be used on request and atlas copy plates are freely available.

References

1. West, R.M. and Dumoulin, B., 1974 "Photographic Reproduction of Large Astronomical Plates", Report from ESO SAL
2. West, R.M., 1978, "Copying at ESO", in "Modern Techniques in Astronomical Photography", eds. R.M. West and J.L. Heudier, ESO, p. 193
3. West, R.M. and Dumoulin, B., 1980, "Photographic Reproduction Large Astronomical Glass Plates: Some Problems and Pitfalls", AAS Photobulletin 23, p. 3
4. Malin, D.F., "Unsharp Masking", AAS Photobulletin, No. 16, 1977
5. Madsen, C., "Photographic Image Manipulation", ESO Messenger, No. 28, 1982, p. 19
6. Malin, D.F., "Photographic Amplification of Faint Astronomical Images", Nature, No. 276, 1978, p. 591
7. Malin, D.F., "Colour Photography in Astronomy", Vistas in Astronomy, No. 24, Part 3, 1980, p. 219
8. Madsen, C. and Tarenghi, M., "Astronomical Colour Printing at ESO", ESO Messenger, No. 30, 1982, p. 15
9. Ciba-Geigy AG/Ilford AG, Cibachrome TB 29 EN (Fribourg 1979)

PHOTOGRAPHIC MATERIALS

Purpose	Material (Name and Type)	Process	Processing Machine	Manual Processing Tray or Tank	Remarks
Atlas copy plates Atlas neg. plates	Kodak Process Plates	D-76	Tray Rocker		
Atlas film copies	Kodak SO-261 Duplicating Film	Versaflo	Versamat		
B/w Intermediate film (general purpose)	Kodak Commercial 4127 Film	Versaflo	Versamat		
	Kodak SO-261 Duplic. Film	"	"		
	Kodak Commercial 4127 Film	D-76		Tray	Masking film
	Kodak Commercial 4127 Film	Microdol-X		Tank	
	Kodak Kodalith Type III 4556	Versaflo	Versamat		Ultra-high contrast
	Kodak Kodalith Type III 4556	Dokulith		Tray	
	Kodak Kodalith Type III 4556	Kodak Fine- Line Dev.		"	Diffuse-light amplification
	Agfa RA 710 P	Ilfospeed or Veribrome Dev.		"	" "
	Kodak PLUS-X Professional	Microdol-X		Tank	General photography
B/w prints	Kodak Kodabrome II RC F & N Kodak Mural	Veribrome Eukobrom	RP-X-OMAT	Tray	Murals
B/w slides	Kodak Panatomic-X	Direct Pos. Film Dev. Outfit		Tank	Cont. tone slides
	Kodak Technical Pan TP-2415	" " "			" " "
	Kodak Technical Pan TP-2415	Microdol-X		Tank	(reversed)
	Agfa Ortho 25	Dokulith + Tetenal Blue toner F		Tank	Line slides (white line, blue background)
	Agfa Diadirekt	Commercial lab			Cont. tone slides
General line work	Agfa Copyproof CPN combined with CPG/ CPP/CPF/CPFM/CPRV Receiving paper/film Kodak Kodalith Ortho, Type III, 4556	Copyproof CP-298B	CP-42		Line copies on-film or on-paper
		Dokulith		Tray	
Large colour transparencies	Ektachrome 6117	E-6	Commercial lab		
	Ektachrome 6118	"	" "		
	Ektachrome 6121 Dupl. Film	"	" "		Colour composites
	CIBA CTD-F7 Kodak Ektaflex PCT	CIBA P3 Ektaflex	Autopan 60-400 Ektaflex 8M		OH-Film
Colour slides	Ektachrome 64 Professional EPR Ektachrome 50 Professional EPY	E-6	Commercial lab		
			" "		
Colour prints	Cibachrome CPS 1K Cibachrome CRC 44M	CIBA P3 " "	Autopan 60-400 " "		