



Science Vision 2015+ The ASPERA view

Science Vision 2015+

Poitiers, January 23-25 2007

S.Katsanevas

CNRS coordinator ASPERA

www.aspera-eu.org



History 1: ApPEC (Astroparticle Physics European Co-ordination)

- **ApPEC aims (2001)**
 - Promote and facilitate co-operation within the growing European Particle Astrophysics community
 - Develop and promulgate long term strategies for European PA, offering advice to national funding agencies or institutions, ESF, and EC and other
 - Assist in improving links and co-ordination between European PA and the scientific programmes of organisations such as CERN, ESA, and ESO
 - Express their collective views on PA in appropriate international forums, such as EC, OECD, UNESCO etc.
- **ApPEC membership**
 - At the outset it comprised the national funding agencies of France CNRS/CEA, Germany BMBF, Italy INFN, the Netherlands NIKHEF and the UK PPARC.
 - Since then Spain, Belgium, Portugal, Greece, and Switzerland have joined
 - Recently Poland has expressed interest in joining.
 - Eligibility: Funding Agencies (decision making body, having a national coordinating role)



History 2: ApPEC Operation

- **ApPEC operates**
 - strategically through its **Steering Committee** and operationally with the wider academic community through its **Peer Review Committee**
 - Observers from **ESA, ESF, ESO, CERN**
- **Steering Committee (SC)**
 - **France:** M.Spiro, S.Katsanevas, C. Cavata, **Germany:** T. Berghöfer, R.Köpke, H. Bluemer, **Netherlands:** F. Linde, **UK:** A. Coates, R. Wade, **Italy:** R. Petronzio B. Dettore, **Spain:** D. Espriu, A.Ferrer, **Switzerland:** M. Bourquin, **Belgium:** D. Bertrand, C. DeClerq, **Portugal** K. Gaspar **Greece:** D. Nanopoulos,
- **Peer Review Committee (PRC)**
 - Frank Avignone, Jose Bernabeu, Pierre Binetruy, Hans Bluemer, Karsten Danzmann, Franz v. Feilitzsch, Enrique Fernandez, Werner Hofmann, John Iliopoulos, Uli Katz, Paolo Lipari, Manel Martinez, Antonio Masiero, Benoit Mours, Francesco Ronga, Andre Rubbia, Subir Sarkar, Guenther Sigl, Gerard Smadja, Nigel Smith, Christian Spiering, Alan Watson
- **ApPEC actions:**
 - **13 ILIAS (underground labs and Grav waves, the HE part did not pass the EU procedure)**
 - **Review by the PRC of 6 major fields of astroparticle, suggestions of merging of projects**
 - **KM3 (Neutrino telescope in the mediterranean, ESFRI list)**
 - **ASPERA**



Start 1st July 2006 (3y)

ASPERA



17 agencies 12 countries + CERN:

1. Belgium FNRS/FWO
2. Czech Rep. MEYS
3. France CEA/CNRS
4. Germany BMBF/PTDESY
5. Greece DEMOKRITOS
6. Italy INFN
7. Netherlands FOM
8. Portugal FCT
9. Spain MEC/FECYT
10. Sweden VR
11. Switzerland SNF
12. UK PPARC
13. CERN



ASPERA in Europe

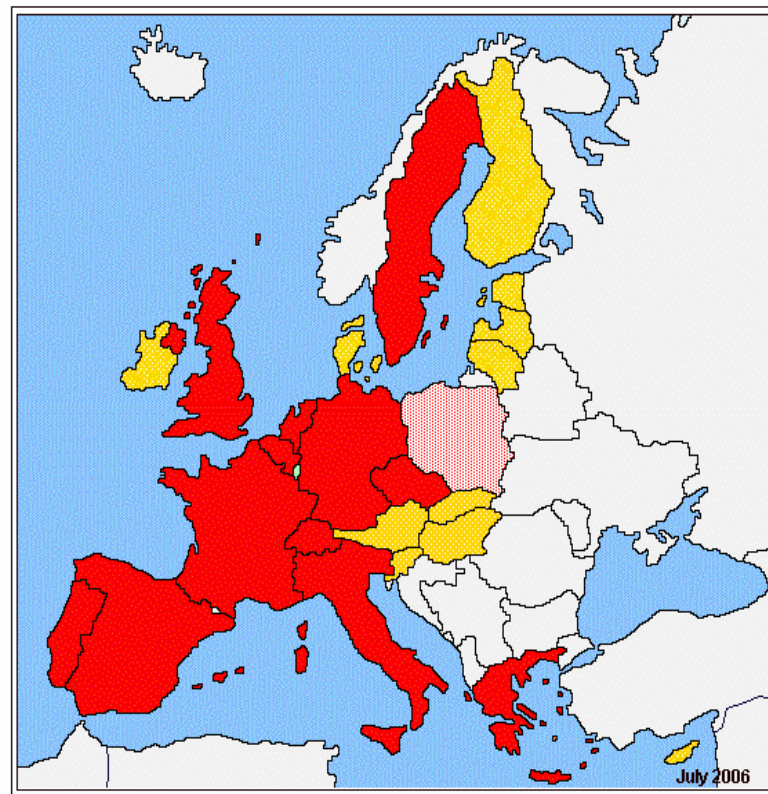

- Participating to ASPERA
- Future Participation expected
- Not participating to ASPERA



5 workpackages

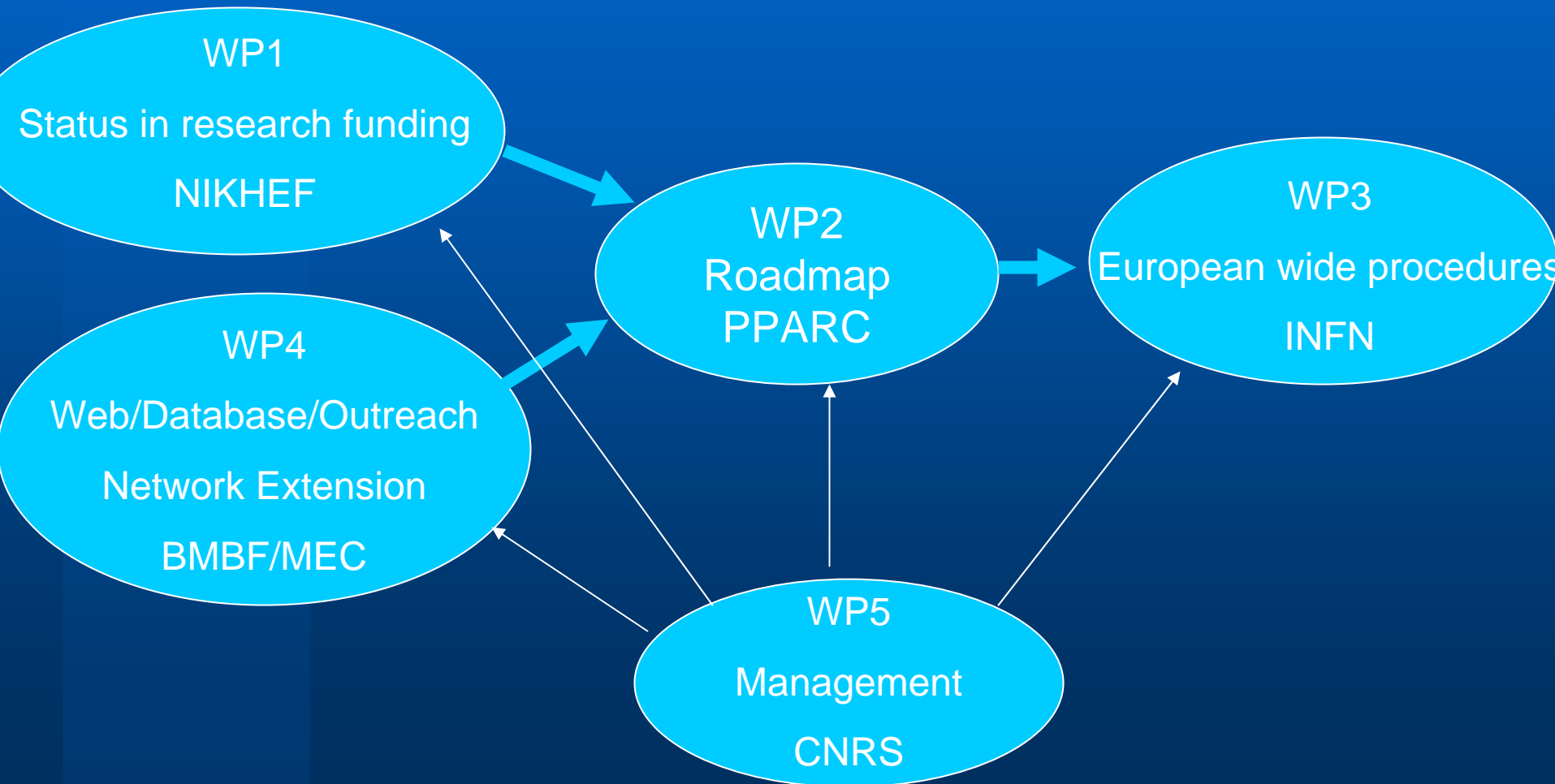



Goals of ASPERA (reverse engineering)

- **(WP3) Prepare the ground for**
 - Common European Funding of at least one large infrastructure
 - A common call on R&D
 - Alignment of procedures of evaluation to fund future common projects
- **(WP2) In order to do so one needs:**
 - A common roadmap (3 phases)
 - Phase I list of opportunities: Wshop: Valencia Nov 2006, Pub: March 2007
 - Phase II projection of resources, WG meetings, Wshop: September 20-21 Amsterdam, Pub: early 2008
 - Phase III priority list, end of 2008 - mid 2009
 - A posteriori linking of existing infrastructures
- **(WP1) A prerequisite of the above is:**
 - Detailed assessment of the resources available
 - questionnaires, workshops, national days
 - Identification of the legal/financial barriers to coordination and a census of possible legal forms of cooperation
 - Census of evaluation procedures (people, projects, laboratories)
 - Common electronic tools (database, web)



Astroparticle Physics, a definition through 6 questions*

From Phase I roadmap

1. What is the Universe made of ?
2. Do protons have a finite life time ?
3. What are the properties of neutrinos ? What is their role in cosmic evolution ?
4. What do neutrinos tell us about the interior of Sun and Earth, and about Supernova explosions ?
5. What is the origin of cosmic rays ? What is the view of the sky at extreme energies ?
6. What is the nature of gravity ? Can we detect gravitational waves ? What will they tell us about violent cosmic processes ?

*"Science is the art of replacing unimportant questions that can be answered by important ones which cannot" Edward B. Ferguson Jr. 1976.



What is the Universe made of ? 1

- Dark matter: WIMPS **direct** and indirect, axions from Sun
- Dark energy (not addressed in detail but closely related to dark matter)
- Other particles beyond the standard model
- Cosmic antimatter

Soon: Pamela, later: AMS

> 2010:

Two direct-search experiments with 10^{-10} pb sensitivity

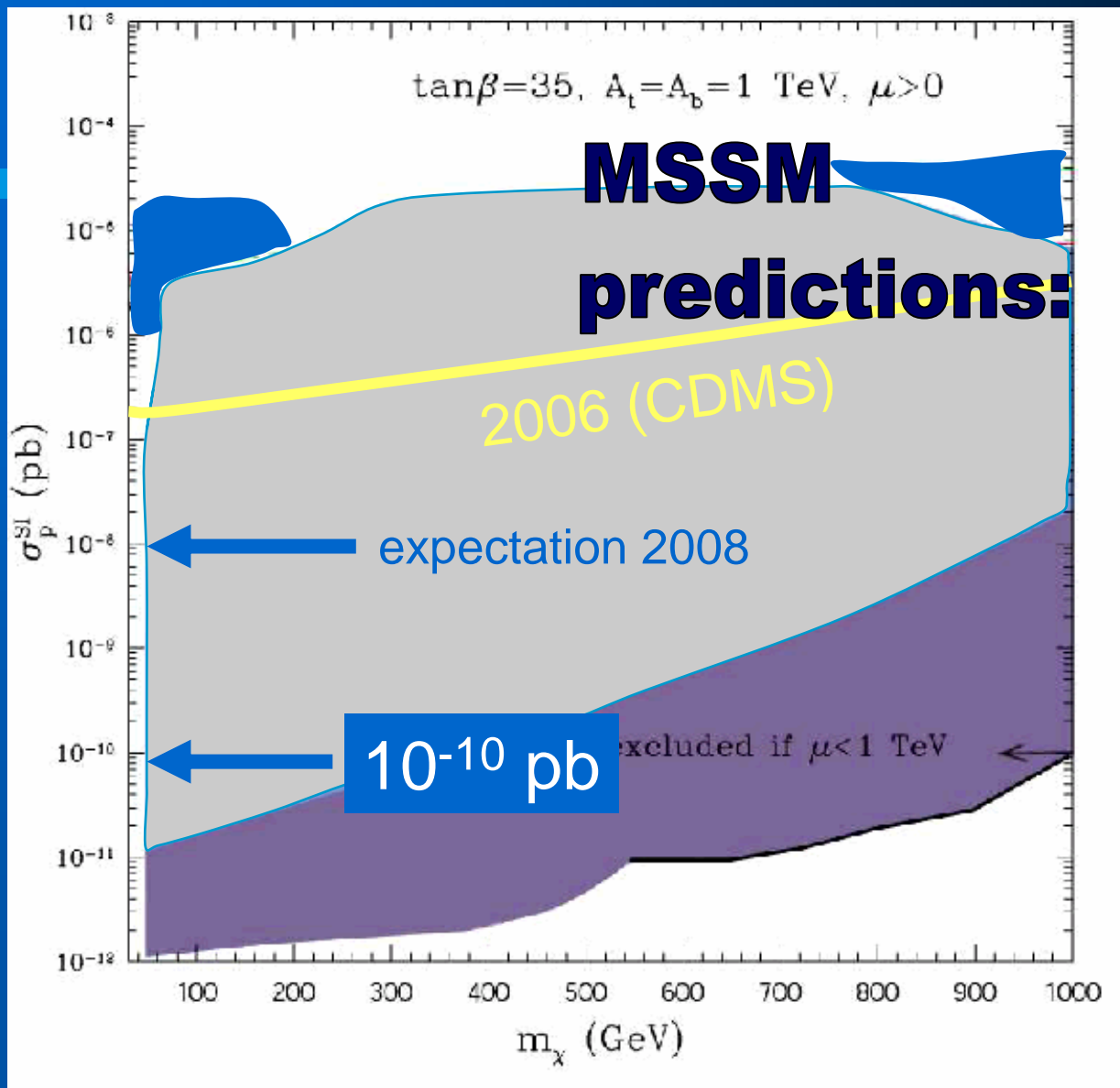



DM: > 50 M€ projects

Field/ Experiment	cost scale (M€)	Desirable start of construction	Remarks
Dark Matter Search: Low background experiments with 1-ton mass	60-100 M€	2011-2013	two experiments (different nuclei, different tech- niques), e.g. → 1 bolometric → 1 noble liquid more than 2 expt's worldwide

Background, background, background !
Expect technical proposals ~ 2009/10



What are the properties of neutrinos ?

What is their role in cosmic evolution ?

3

Spectrum endpoint and $\beta\beta$, oscillations at reactors

Soon: KATRIN

Soon: Double CHOOZ

>2010: ~2 experiments
with sensitivity to
test inverse hierarchy



DBD: > 50 M€ projects

Field/ Experiment	cost scale (M€)	Desirable start of construction	Remarks
Properties of neutrinos: Double beta experiments	60-80 M€	2011-2013	1) Explore inverted hierarchy scenario 2) two experiments with different nuclei (techniques) worldwide 1 ton

- 20-50 meV range requires active mass of order one ton, good resolution, low BG. Need several isotopes.



Do protons have a finite lifetime ?

2



Ultimate price tag
400-800 M€

≥ 2015:

A very large multi-purpose facility

Options:

- Water Megatonne („MEMPHYS“)
- 100 kton Liquid Argon („GLACIER“)
- 50 kton scintillaton detector („LENA“)



What do neutrinos tell us about the interior of Sun and Earth, and about Supernova explosions ?

4

Soon: Borexino



Ultimate price tag
400-800 M€

≥ 2015:

A very large multi-purpose facility

Options:

- Water Megatonne („MEMPHYS“)
- 100 kton Liquid Argon („GLACIER“)
- 50 kton scintillaton detector („LENA“)



MEMPHYS:
Water Cherenkov,
(420 kton -1 Mton)

LENA:
Liquid Scintillator
(30-70 kton)

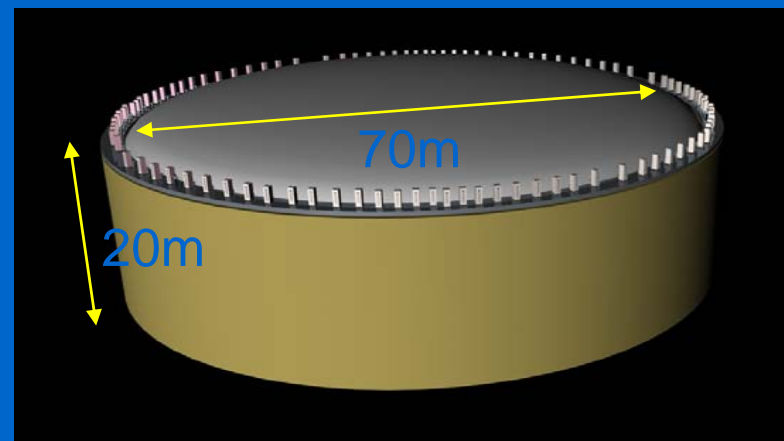
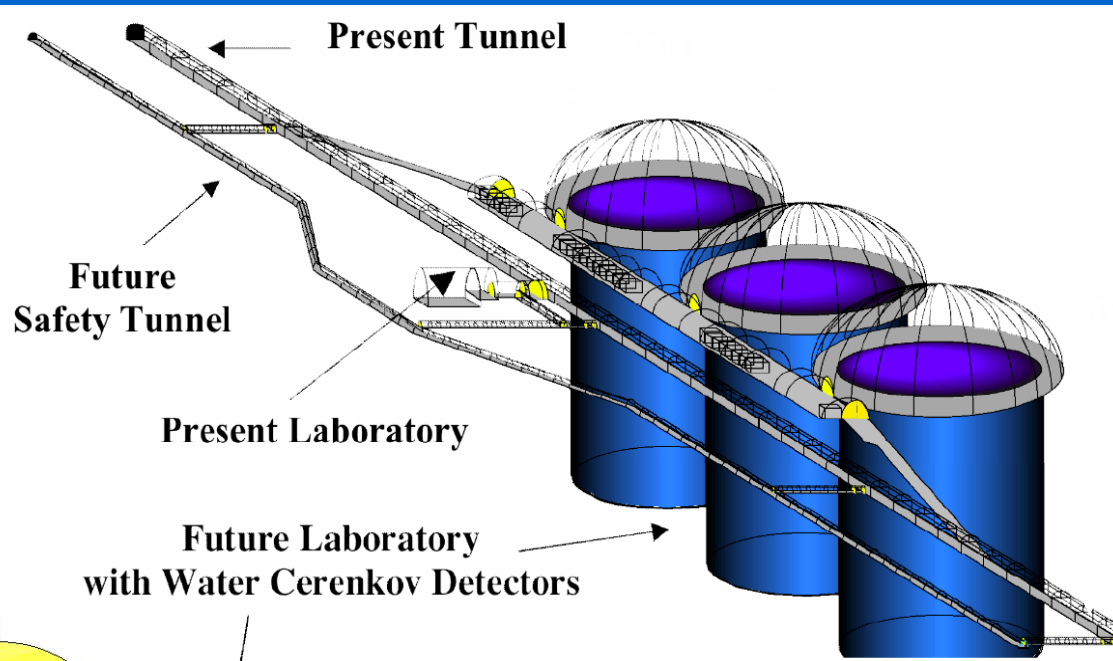
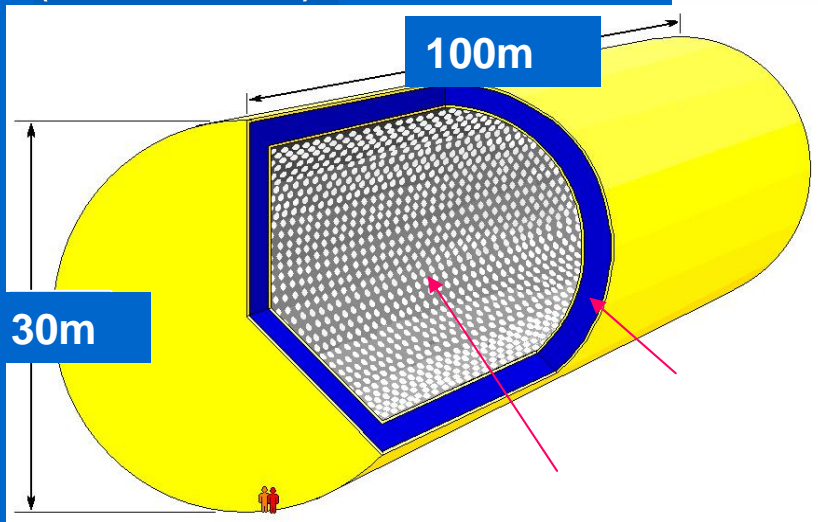

GLACIER: Liquid Argon (50 -100 kton)



p-decay & nu-astronomy: > 50 M€ projects

Field/ Experiment	cost scale (M€)	Desirable start of construction	Remarks
Proton decay and low energy neutrino astronomy: Large infrastructure for p-decay and ν astronomy on the 100kt-1 Mton scale	400-800 M€	Civil engineering :2012-2013	<ul style="list-style-type: none">- multi-purpose- 3 technological ..options- needs huge new ..excavation- most of expen- ditures after ..2015 worldwide sharing

→ **LAGUNA DS**



What is the origin of high energy cosmic rays ?

What is the view of the sky at extreme energies ?

5

Charged cosmic rays, neutrinos, TeV γ

Started: Auger
>2008:
Auger North
>2015: EUSO ?

> 2009: KM3Net
under construction:
IceCube

H.E.S.S., Magic →
Very Large Array(s)
(„CTA“, > 2009)
also: Argo/YBJ



High Energy Photon Sky: Source Count vs. Year

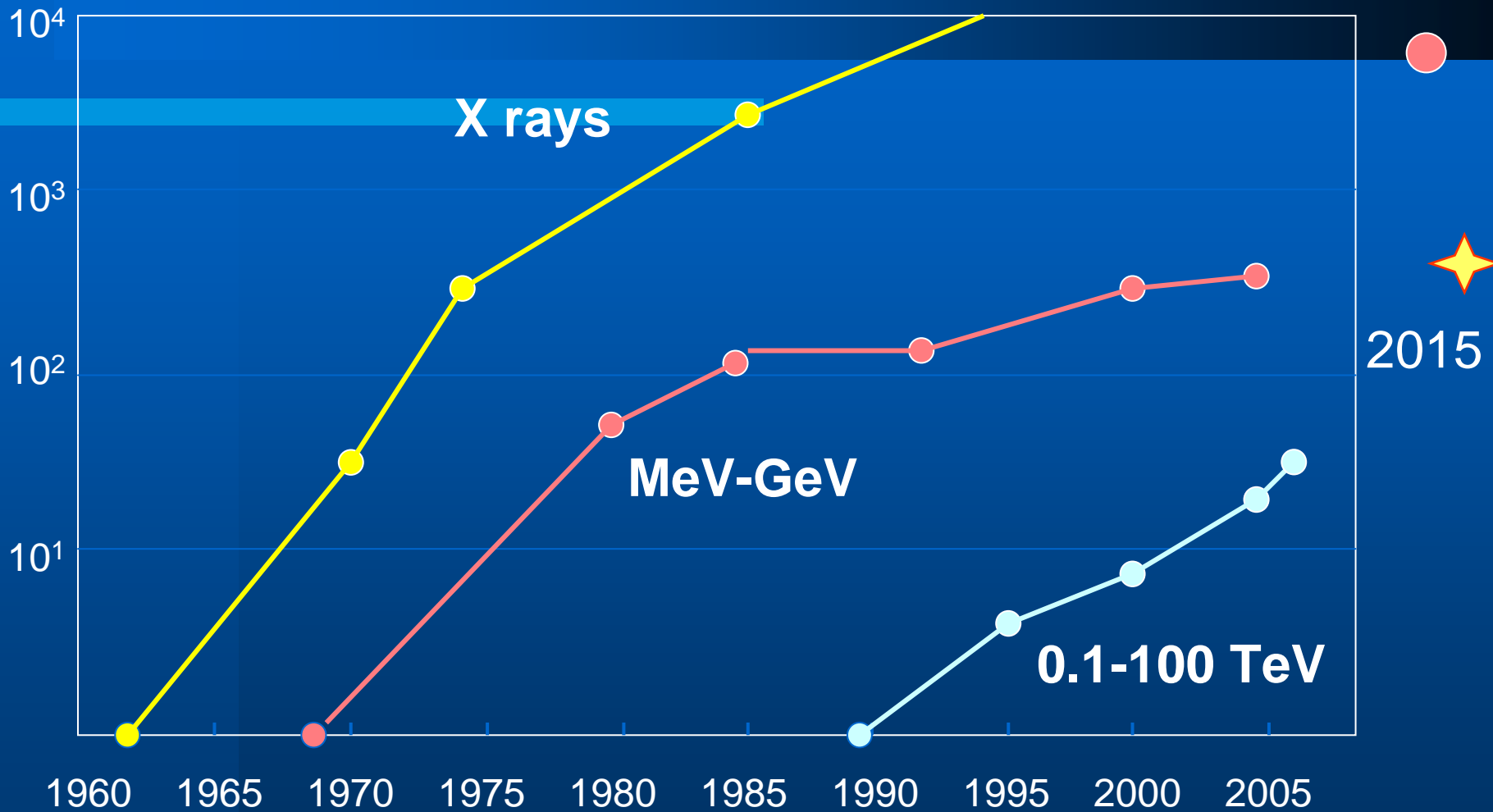

(modified from M. De Naurois, astro-ph/0409361)



Field/ Experiment	cost scale (M€)	Desirable start of construction	Remarks
High Energy Univ. <u>Gamma Rays</u>			Physics potential well defined by rich physics from present γ exp's
Cherenkov Telescope Array CTA	100 M€ South 50 M€North	First site 2010	
<u>Charged Cosmic Rays</u>			Confirmation of physics potential from Auger South expected in 2007
Auger North	85 M€	2009	
<u>Neutrinos</u>			FP6 design study Confirm. of physics potential from IceCube and gamma telescopes expected in 2008-10
KM3NeT	300 M€	2011	

HE Universe: > 50 M€ projects



What is the nature of gravity ?

Can we detect gravitational waves ?

What will they tell us about violent cosmic processes ?

6



Now:

-GEO-600,

-VIRGO (VIRGO+, advVIRGO),

> 2010: - 3rd Generation Facility

Price tags

LIGO: 260 M€ (US costing)
only US

Adv.Ligo: +210 M€ (dito)
30 M\$ Germ. + UK

VIRGO: 85 M€ (cap.invest)
3rd Gen Fac.: 200 M€ (?)



Gravitational Waves: > 50 M€ projects

Field/ Experiment	cost scale (M€)	Desirable start of construction	Remarks
Gravitational waves: Third generation interferometer	250-300 M€	Civil engineering 2012	Conceived as underground laboratory

Recomendations: Welcome LISA which complements Earth bound detectors towards sub-Hz range and enables observation of a wealth of sources.

Phase I Assessing the opportunities of the field

- Examination of the subfields by the ApPEC/PRC in thematic workshops (2003-2005)
- A preliminary census of 66 astroparticle projects (2005-2006)
- Draft proposal ready . Feedback by agencies, projects leaders , experts etc.
- Valencia workshop 6/7 November 2006: Public presentation of the proposal and first discussion by 7 thematic groups:

1. High Energy γ Rays **M. Martinez, G. Herman**
2. ν Mass **F. Piquemal , A. Giuliani**
3. High Energy Cosmic Rays **H. Bluemer**
4. High Energy ν **U. Katz, P. Lipari**
5. Dark Matter direct detection **N. Smith, G. Gerbier**
6. Gravitational Waves **H. Lueck**
7. Low Energy ν and Proton decay **A. Rubbia,**

Phases II and III

- **Phase II: intra-thematic prioritisation, resource projection**
 - Internal meetings of the 7 working groups (November 2006-April 2007)
 - Final thematic mini-workshops, with the participation of the PRC to examine, uniformize the criteria of the 7 thematic propositions (May 2007-July 2007)
 - The thematic propositions must contain beyond what is present in phase I:
 - a. Detailed calendar (phasing, milestones, review points)
 - b. Detailed multi-annual projection of budget and human resources
 - c. Detailed exposition of enabling R&D
 - d. Maximal possible prioritization within the thematic.
 - **Final synthesis: Amsterdam 20-21 September 2007**
 - **Phase II Roadmap January 2008**
- **Phase III: Inter-thematic prioritisation**
 - Selected hearings by the PRC of experts on thematic groups
 - Discussions in ApPEC and agencies
 - **Deliverables July 2008**
 - Roadmap with selected priorities (action plan)
 - Definition of areas where common R&D calls can be launched
 - Preparation of agreements for next phase large infrastructures



A Cost Scenario 2010-2015

■ DM: Eureka 100% + Noble gas 100%	150 M€
■ $\beta\beta$: Gerda+Majorana 50% + “X” 100%	100 M€
■ One large detector for low en nu and proton decay (35% before 2016)	250 M€
■ Cost for one large TeV gamma array	100 M€
■ KM3Net	300 M€
■ Auger North (33%)	30 M€
■ Gravitational Waves (EGO)	250 M€
■ Smaller projects, R&D	200 M€
■ <i>Sum</i>	<i>1400 M€</i>

→ 300 M€ per year (now 135 M€) → factor 2

→ manpower not always included



Conclusion

- ***ASTROPARTICLE LARGE INFRASTRUCTURES ARE NOW AT THE LEVEL OF FUNDING OF PARTICLE PHYSICS NUCLEAR PHYSICS AND LARGE ASTROPHYSICS INFRASTRUCTURES.***
- ***SHOULD BE READY TO PARTICIPATE AT THE TIME OF THE WORLD DISTRIBUTION OF LARGE INFRASTRUCTURES (ca 2010-2012)***
- ***ASPERA's AMBITION IS TO BE THE INSTRUMENT OF THE PREPARATION (IN COLLABORATION WITH ASTRONET ON THE REGIONS OF OVERLAP) FOR EUROPE AND COORDINATION WITH THE OTHER REGIONS OF THE WORLD***