



ESO - EUROPEAN SOUTHERN OBSERVATORY

EUROPEAN SOUTHERN OBSERVATORY
Organisation Européenne pour des Recherches Astronomiques dans l'Hémisphère Austral
Europäische Organisation für astronomische Forschung in der südlichen Hemisphäre

VERY LARGE TELESCOPE

Specifications for the PRIMA Metrology data files, data logging and algorithms

Doc. No.: VLT-SPE-ESO-15736-3899

Issue: 3

Date: 30.11.2012

Prepared: S.Leveque/N.Schuhler

Name Date Signature

Approved: F.Delplancke

Name Date Signature

Released: R.Gilmozzi

Name Date Signature

ESO	Specifications for the PRIMA Metrology data files, data logging and algorithms	Doc:	VLT-SPE-ESO-15736-3899
		Issue:	3
		Date:	30/11/2012
		Page:	2 of 41

CHANGE RECORD

Issue	Date	Affected Paragraphs(s)	Reason/Initiation/Remarks
1	02/04/08	All	Issue for PRIMA PAE
2	25/7/11	All	Update after commissioning
3	30/11/2012	Section 2 Section 5.2.1.2 Section 9.5	Added reference to the document describing the modification of the phasemeter firmware: VLT-MAN-ESO-15734-4535-iss2 Section removed (obsolete, covered by the above document)

ESO	Specifications for the PRIMA Metrology data files, data logging and algorithms	Doc:	VLT-SPE-ESO-15736-3899
		Issue:	3
		Date:	30/11/2012
		Page:	3 of 41

TABLE OF CONTENTS

1	Scope	5
2	Applicable and Reference Documents.....	5
3	List of Abbreviations/Acronyms.....	5
4	Conventions used by the PRIMA metrology	6
5	Phase-Meter Sub-system	8
5.1	Introduction.....	8
5.2	Operation with the first phase meter (PrimetA-B) using lprmac	8
5.2.1	Phase meter algorithms running on lprmac.....	8
5.2.1.1	How to compute ΔL from the data delivered by the phase meter:	8
5.2.1.2	Definition of the warnings and flags.....	9
5.2.1.3	HW Reset and SW Referencing.....	11
5.2.2	Information written by lprmac on the RMN	12
5.2.3	Engineering files	12
5.3	Operation with the second phase meter (PRIMET-B) using lprma2	14
5.3.1	Operation of the PRIMET-B phase meter and Algorithms running on lprma2	14
5.3.2	Information written by lprma2 on the RMN	14
5.3.3	Engineering files written by lprma2.....	15
5.4	Automatic Fitslog generated by lprmac and lprma2	15
5.5	Plot tools	16
6	Laser frequency stabilization sub-system.....	18
6.1	Introduction.....	18
6.2	Operation of the Lightwave laser.....	18
6.3	Operation of the Innolight laser model MIR 500NE-FC	19
6.4	Tuning of the transmission of the AOM's	21
6.5	Automatic procedure to close the frequency stabilization loop:	22
6.6	Operation of the laser in the simplified mode, possibility to ignore devices	23
6.7	Engineering file.....	24
6.8	Automatic Fitslog	25
6.9	Plot tools	27
6.10	Annotated example of pmlss.dbcfg file	27
7	Pupil tracking sub- system.....	27
8	Information passed to ISS.....	27
9	Appendix.....	30
9.1	Phase meter performance summary	30
9.2	Estimation of ΔL from the raw phase meter data.....	31
9.2.1	Configuration:.....	31
9.2.2	Differential OPD estimated from the phase meter connected to lprmac.....	32
9.2.2.1	Case 1: DDL1 tracking (normal mode) and DL4 tracking.....	32
9.2.2.2	Case 2: DDL1 tracking (normal mode) and DL2 tracking.....	32
9.2.2.3	Case 3: DDL2 tracking (swap mode) and DL4 tracking	33
9.2.2.4	Case 4: DDL2 tracking (swap mode) and DL2 tracking.....	33
9.2.2.5	Error analysis	34
9.2.2.6	Conclusion:	34
9.2.3	OPD in the B-channel estimated from the phase meter connected to lprma2	34
9.2.3.1	Case 1: D_{ip2} is changing	35
9.2.3.2	Case 2: D_{ip4} is changing	35
9.2.3.3	Conclusion:	36

ESO	Specifications for the PRIMA Metrology data files, data logging and algorithms	Doc:	VLT-SPE-ESO-15736-3899
		Issue:	3
		Date:	30/11/2012
		Page:	4 of 41

9.3	Annotated example of pmlss.dbcfg.....	36
9.4	Annoted example of pmpsd.dbcfg	40

ESO	Specifications for the PRIMA Metrology data files, data logging and algorithms	Doc:	VLT-SPE-ESO-15736-3899
		Issue:	3
		Date:	30/11/2012
		Page:	5 of 41

1 SCOPE

The Purpose of this document is to

- Define the raw data format delivered by PRIMET including the content of the header
- Define the format and content of the engineering files for the phase meter, frequency stabilization and the alignment sub-systems.
- Define the parameters to be logged during operation

2 APPLICABLE AND REFERENCE DOCUMENTS

Ref	Document Number	Issue	Date	Title
AD 1	VLT-TRE-ESO-15730-3000	2	2/4/08	PRIMA metrology design description
AD 2	VLT-TRE-IMT-15734-3726	1	20/7/05	As built Phase Meter configuration for the PRIMA Metrology System
AD 3	VLT-TRE-ESO-15732-4087	1	26/9/06	Design of the Pupil tracker for PRIMET
AD 4	VLT-MAN-ESO-15734-4535	2	30/11/2012	Modifications of the phasemeter firmware since delivery of “as built” documentation

Ref	Document Number	Issue	Date	Title
RD 1	VLT-TRE-ESO-15731-3884	1	26/6/06	Test of the laser frequency stabilization system of the PRIMA Metrology System

3 LIST OF ABBREVIATIONS/ACRONYMS

AT: Auxiliary Telescope
FOV: Field of view
LCU: Local Control Units
TBC: To be Confirmed
STS Star Separator

ESO	Specifications for the PRIMA Metrology data files, data logging and algorithms	Doc:	VLT-SPE-ESO-15736-3899
		Issue:	3
		Date:	30/11/2012
		Page:	6 of 41

4 CONVENTIONS USED BY THE PRIMA METROLOGY

ν =Laser frequency

Channel A (FSUA or AMBER,MIDI)		Channel B (FSU B)	
IP3	IP1	IP4	IP2
$\nu+38.65\text{MHz}$	$\nu+38\text{MHz}$	$\nu-39.55\text{MHz}$	$\nu-40\text{MHz}$
Polarization P	Polarization S	Polarization P	Polarization S
$f_a = 650\text{kHz}$ $\text{OPD}_a = \text{IP3} - \text{IP1} > 0$		$f_b = 450\text{kHz}$ $\text{OPD}_b = \text{IP4} - \text{IP2} > 0$ (also used for phase compensation)	
$\Delta\nu = 78\text{MHz}$			
$f_a - f_b = 200\text{kHz}$			
$\Delta L = \text{OPD}_a - \text{OPD}_b > 0$			
or $\Delta L = \text{IP3} - \text{IP1} - \text{IP4} + \text{IP2}$			

Table 1: Allocation of the Metrology channels and heterodyne frequencies to the VLTI instruments and input channels.

Justification:

If the frequency of 200kHz Probe signal decreases, the recorded phase will increase because the number of clock counts between the rising edge of the 200kHz reference signal and falling edge of the 200kHz Probe signal will increase. Inversely if the frequency of 200kHz Probe signal increases, the recorded phase will decrease.

If the OPD increases in the interferometric arm where the $\nu+38.65\text{MHz}$ laser components propagates, this component will be red-shifted. The frequency of the 650 kHz beat frequency will decrease, thus the frequency of the $200\text{kHz} = 650\text{kHz} - 450\text{kHz}$ will decrease. As described above, the recorded phase will increase.

Similarly we have:

OPD in $\nu+38\text{MHz}$ increases \rightarrow 650kHz increases \rightarrow 200kHz increases \rightarrow recorded phase decreases

OPD in $\nu-40\text{MHz}$ increases \rightarrow 450kHz increases \rightarrow 200kHz decreases \rightarrow recorded phase increases

OPD in $\nu-39.55\text{MHz}$ decreases \rightarrow 450kHz decreases \rightarrow 200kHz increases \rightarrow recorded phase decreases

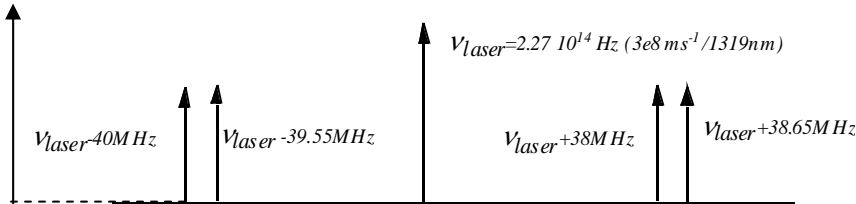

The possible configurations are

Channel A (FSUA or AMBER,MIDI)		Channel B (FSU B)	
IP3	IP1	IP4	IP2
$\Delta L = \text{IP3} - \text{IP1} - \text{IP4} + \text{IP2}$			
Solution 1 (implemented)			
$\nu+38.65\text{MHz}$	$\nu+38\text{MHz}$	$\nu-39.55\text{MHz}$	$\nu-40\text{MHz}$
Solution 2 (not implemented)			
$\nu-40\text{MHz}$	$\nu-39.55\text{MHz}$	$\nu+38\text{MHz}$	$\nu+38.65\text{MHz}$

ESO	Specifications for the PRIMA Metrology data files, data logging and algorithms	Doc:	VLT-SPE-ESO-15736-3899
		Issue:	3
		Date:	30/11/2012
		Page:	7 of 41

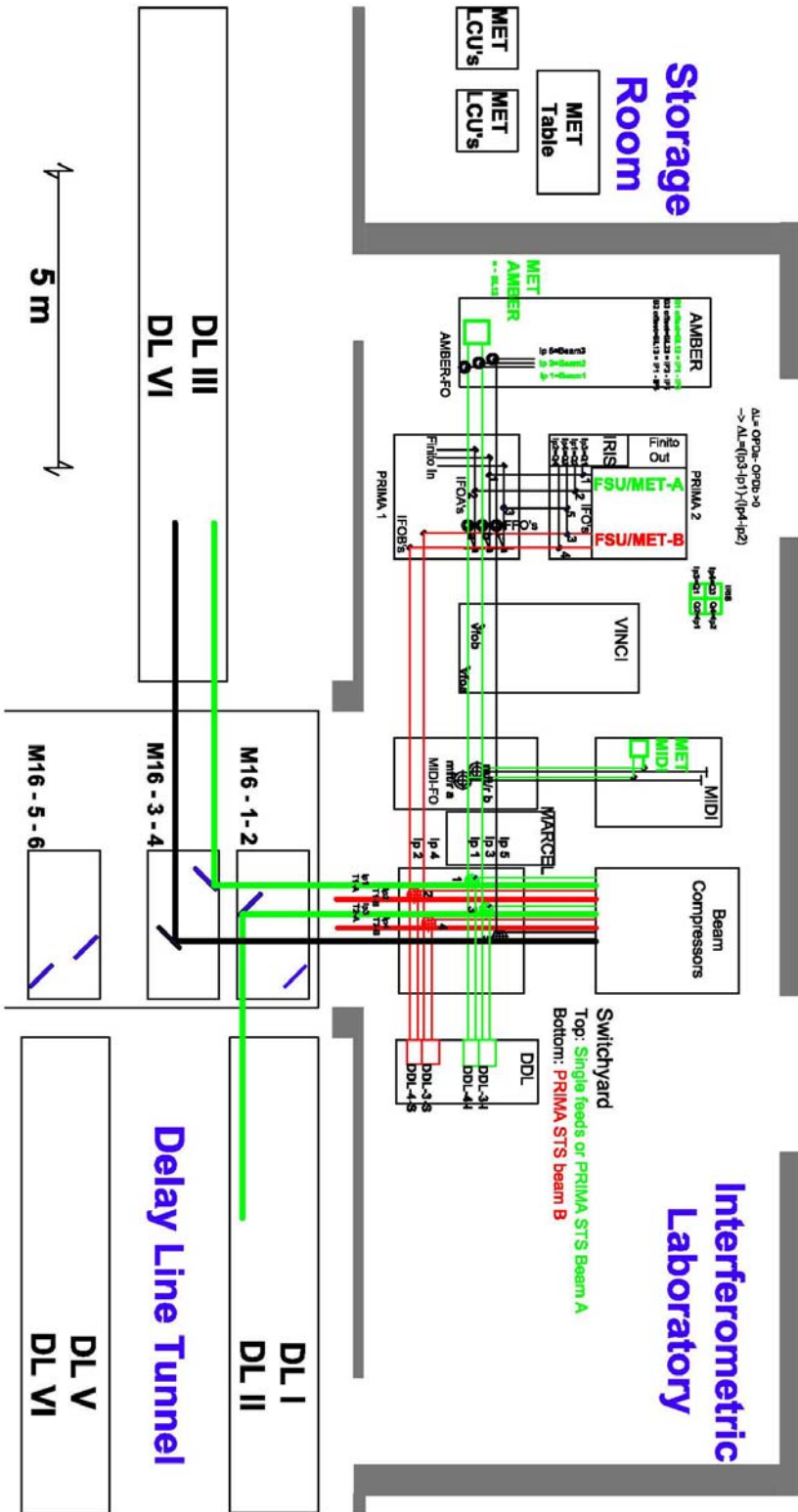

Figure 1: Configuration of the instruments and input channels (ip's) inside the VLT laboratory

ESO	Specifications for the PRIMA Metrology data files, data logging and algorithms	Doc:	VLT-SPE-ESO-15736-3899
		Issue:	3
		Date:	30/11/2012
		Page:	8 of 41

5 PHASE-METER SUB-SYSTEM

5.1 Introduction

Two phase meters are operated in parallel.

- The first phase meter, which is fed by 4 optical signals, is connected to the **lprmac** LCU and delivers the differential OPD corresponding to $\Delta L_1 = OPD_{CHA} - OPD_{FSUB} = IP3 - IP1 - IP4 + IP2$
- The second phase meter is connected to the **lprma2** LCU. It is fed by electrical signals generated from the first phase meter and delivers the “pseudo differential OPD” corresponding to “ $\Delta L_2 = 0 - FSUB = -IP4 + IP2$ ”. The second phase meter does not use the Preamplifier board (hosting Photodiodes). Therefore the DC level of the photodiodes are not relevant.

Using ΔL_1 and ΔL_2 published on the Reflective Memory, one can reconstruct the individual OPD's in CHA and CHB for vibration control or calibration of the FSU's. However there are 2 limitations:

- the OPD are monitored up to the STS (i.e it does not include the coude train)
- the error on the measured OPD due to residual fluctuation of the laser frequency (relative stability of 1.e-8) will potentially reach about 0.6 nm rms per m of OPD. For an OPD of 120m, the error becomes 72 nm. The measurement range is 346 mm. After this value, the phase meter overflows and the data are wrapped.

The user interface for both phase meter is : *pmacqgui*

The phase meter is described in AD 2 as well as all modifications implemented after delivery in AD 4

5.2 Operation with the first phase meter (PrimetA-B) using lprmac

5.2.1 Phase meter algorithms running on lprmac

5.2.1.1 How to compute ΔL from the data delivered by the phase meter:

Based on AD 2, ΔL is computed from the data delivered by the phase meter as follow:

$$\Delta L = \frac{c}{2\nu} \left(\frac{\phi_{sum}^{del}}{1024 \cdot (N + 1)} + \frac{\Delta \nu}{\nu} \cdot \phi_{FC}^{del} \right) - \Delta L_{ref} = \Delta L_{PM} + \varepsilon_{FC} - \Delta L_{ref} \quad (\text{in m}) \quad (\text{eq. 1})$$

where :

- ϕ_{sum}^{del} is the summed phase delivered by the phasemeter expressed in digits (1 digit = $2\pi/1024$ rad corresponding to $\lambda/2/1024 \sim 0.6\text{nm}$)
- ϕ_{FC}^{del} is the value of the error compensation fringe counter delivered by the phasemeter expressed in digit (1 digit = 2π rad, corresponding to $\sim 660\text{nm}$)
- N is the number of samples delivered by the phase meter (integer; maximum value = 400 000 -> 18 bits necessary)
- $\Delta \nu = 78\text{MHz}$ the frequency shift between both metrology channels
- ν is the calibrated frequency of the laser.
- $c = 299792458$ m/s is the speed of light
- ΔL_{ref} is a user selectable reference value used for zeroing (see section 5.2.1.3).

ESO	Specifications for the PRIMA Metrology data files, data logging and algorithms	Doc:	VLT-SPE-ESO-15736-3899
		Issue:	3
		Date:	30/11/2012
		Page:	9 of 41

The laser wavelength can be deduced using $\lambda=c/v/n$

Where n is the air index of refraction. For all computations internal to the metrology system, n should be taken equal to 1.

The lowest significant value of v should correspond to 100kHz.

ΔL should be given with a lowest significant value of $0.1\text{nm}=1.e^{-10}$ m.

(see appendix for the impact of the frequency value, v, used to compute ΔL)

5.2.1.2 Definition of the warnings and flags

The status information delivered by the phase meter is:

Status description	Value when status is "OK"	Color on Phase meter GUI
450kHz Ref detected	1 (LSB)	green
650kHz Ref detected	1	green
450k Probe detected	1	green
650k Probe detected	1	green
PLL Locked	1	green
200kHz Probe detected	1	green
PM Overflow	0	green
FC Overflow	0	green
Trigger detected	1	green
Reset detected	0 (MSB)	green

Known limitations:

1/ The "trigger detected" is always valid: Indeed, the data (and the status) are sent by the phase meter only after receiving a trigger signal. So the collected data will always indicate that a trigger as been detected. This status shall be ignored by the Metrology software.

2/ The "PLL locked" status toggles between states 0 and 1 when the PLL is locked and is continuously at 0 when the PLL is not locked. Therefore, a "real" problem with the PLL shall be flagged if the "PLL locked" status remains at 0 level over more than 3 seconds

Status counters on pmacgui:

For each status (except for trigger detected), a counter is displayed next to the status flag.

The counter indicates how many times the status changed from "signal detected" to "signal not detected" since the last startmet (which resets the counters). When a status "signal not detected" is received, it is compared to the previous one:

- if the previous status was "signal detected" the counter is incremented by one;
- if the previous status was "signal not detected" the counter is not incremented.

The first status obtained after a startmet is ignored as it cannot be compared to a previous status.

Special case for the Reset counter

A reset is achieved by applying 0V to the back plane clear connector of the phasemeter for 10 ms (defined by two ticks of the CPU). This corresponds to several triggers (80 triggers when triggering at 8kHz). For each trigger received by the phasemeter while the clear is hold to 0V, data are sent with a status indicating a "reset detected" and the ΔL_{PM} remains constant (equal to its value when the cleared was started). The counter is incremented in the same way as the other status counters. This means that when adjacent samples present a reset status equal to one (reset detected), the counter is only incremented once.

All counters are cleared by a Startmet.

Warning for no data

This flag appears on the GUI and indicates that the LCU has not updated the data base.

This case typically occurs when a trigger signal is sent to the phase meter while it is switched off.

ESO	Specifications for the PRIMA Metrology data files, data logging and algorithms	Doc:	VLT-SPE-ESO-15736-3899
		Issue:	3
		Date:	30/11/2012
		Page:	10 of 41

Block lost in the engineering

if a block is lost, i.e the slave cpu receives five 5 words or less instead of the 6 normally sent by the phasemeter, the time stamp is written in the file but the other columns are filled with the field (NaN).

Definition of a Glitch (non-valid data)

A glitch occurs if one of the following status counter is non-zero on the pmaqGui or if the corresponding status bit toggles from 1 to 0

- 450Ref (bit 1 of status,LSB)
- 650Ref (bit 2 of status)
- 450Probe (bit 3 of status)
- 650Probe; (bit 4 of status)
- 200kProbe (bit 5 of status)
- PLL Locked (bit 6 of status)

The *PM overflow* (bit 7 of status) and *FC overflow* (bit8 of status) events are not glitches but properties of the phase meters.

A glitch is reported as a “*DATANOTVALID*” keyword on the LogMonitor (see section 5.4)

Definition of the Overflows

- PM Overflow : occurs only if the differential OPD is larger than 150mm. This should **never** occur during PRIMA operation because it is larger than the DDL stroke.
- FC overflow : occurs after ~ 1h30 of operation without RESET (see AD 4). PRIMETAB signal will jump by either 2^{31} or 2^{32} lambda which can be subtracted in post-processing.

For commissioning purposes, the phase meter can use "relaxed" error conditions, meaning that pmaq will not go in state error if a glitch occurs . Glitches are reported

-on the pmaqgui panel

-on the phase meter status written on the rmn

-in the fits header (glitch counters) to possibly see if glitches have incremented between 2 recorded files.

In order to set again the nominal error conditions (glitch= pmaq goes in error), one has to set the following variable to 1 (nominal) instead of 0 (relaxed) on both pmaq_lprmac.dbcfg and pmaq_lprma2.dbcfg (under &INTROOT/config/) and init/standby/online both LCU's:

<ATTRIBUTE>: useStringentChecks

0

A HW reset of the phase meter will zero all internal counters of the phase meter, thus providing the full measuring ranges without overflows. ΔL_{PM} and ε_{FC} will drop to zero.

By default a HW reset is sent before collecting data, meaning that the command STARTMET includes the RESET command.

Warnings for low flux or saturation:

The optical power detected by the 4 photodiodes are available:

- DC.Ref.650kHz
- DC.Ref.450kHz
- DC.Probe.650kHz
- DC.Probe.450kHz

ESO	Specifications for the PRIMA Metrology data files, data logging and algorithms	Doc:	VLT-SPE-ESO-15736-3899
		Issue:	3
		Date:	30/11/2012
		Page:	11 of 41

The delivered DC signals spans from 1.8 V down to 7mV corresponding to a detected optical power of respectively 1.5 μ W¹ and 5.8nW.

A Warning for low flux shall be generated when the recorded DC level drops below 60mV (corresponding to an optical power of 50 nW). The warning shall indicate which photodiode operates at low flux as well as the voltage level.

A Warning for saturation shall be generated when the recorded DC level exceeds 1.6 V (corresponding to an optical power of 1.33 μ W). The warning shall indicate which photodiode operates at low flux as well as the voltage level.

Both warnings shall be logged (see section 5.4)

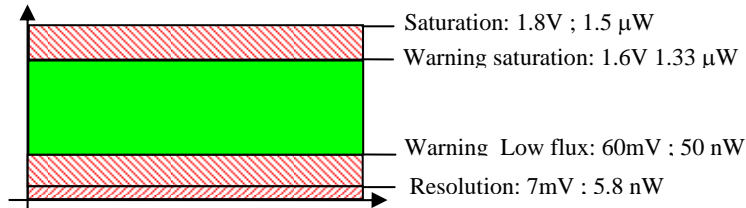

Figure 2: Definition of the operation range for the photodiodes

5.2.1.3 HW Reset and SW Referencing

The HW reset of the metrology is performed by triggering the “Reset” input of the phase meter. The input must be set from 5V to 0V (inverse logic). In case of a HW reset, all counters are set to zero. (1 DO board addressed by the slave CPU)

In addition a SW referencing (REFMET²) can be performed by subtracting to the computed ($\Delta L_{PM} + \epsilon_{FC}$) shown in (eq. 1), a variable called ΔL_{ref} .

ΔL_{ref} can take the following values:

- The current value of ($\Delta L_{PM} + \epsilon_{FC}$) : in that case ΔL will drop to zero
- A previously measured ($\Delta L_{PM} + \epsilon_{FC}$) value taken at a given timestamp (timestamp=user selectable)
- The average value of ($\Delta L_{PM} + \epsilon_{FC}$) taken over the last NNN number of samples (NNN=user selectable)
- 0 (i.e. no zeroing or the effect of the above zeros are cancelled because the phase meter has kept integrating the phase variations)

¹ The photodiodes sensitivity is 1.2 V/ μ W . Saturation occurs for an optical power of 1.4 μ W (i.e 1.68 V output voltage)

The DC signals are digitized using 8 bits with a maximum voltage of 1.8 V (corresponding to 1.5 μ W) . The voltage resolution is $1.8V/2^8=7mV$. The saturation level of the photodiode is 1.4 μ W (optical), slightly below the optical power corresponding to the saturation of the digitized DC signal (1.5 μ W < 1.8 V)

² This command was previously called ZEROMET. The name has been changed to REFMET to better reflect its function and avoid confusion.

ESO	Specifications for the PRIMA Metrology data files, data logging and algorithms	Doc:	VLT-SPE-ESO-15736-3899
		Issue:	3
		Date:	30/11/2012
		Page:	12 of 41

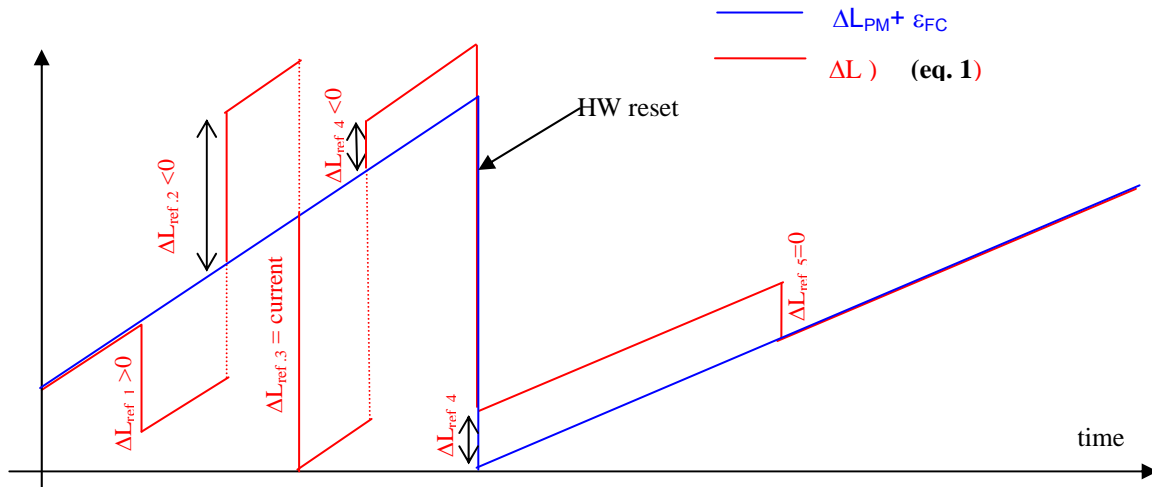

Figure 3: Examples of Referencing

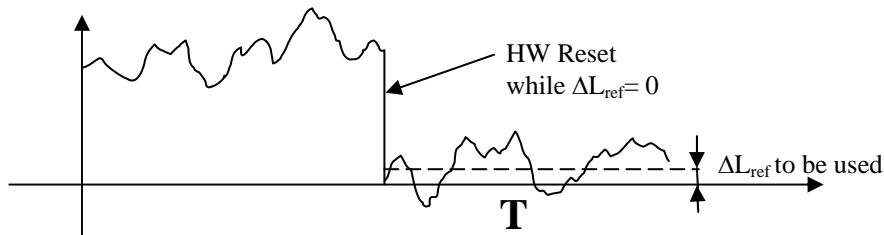

Figure 4: Example of HW reset + average referencing

5.2.2 Information written by lprmac on the RMN

- Time stamp with microsec resolution
- $\Delta L_1 = \text{OPD}_{\text{CHA}} - \text{OPD}_{\text{FSUB}} = \text{IP3} - \text{IP1} - \text{IP4} + \text{IP2}$ with a 0.1 nm resolution
- Metrology status

5.2.3 Engineering files

Objectives: save data to assess the performance of the phase meter
 Acquisition frequency and length: user selectable

Filename: LprmacPhaseMeterYYYY-MM-DDTHH.min.sec.microsec.txt

Header:

Date/Start time: YYYY-MM-DDTHH.MM.SS
 acquisition/loop rate
 Configuration :
 CHA: Instrument

ESO	Specifications for the PRIMA Metrology data files, data logging and algorithms	Doc:	VLT-SPE-ESO-15736-3899
		Issue:	3
		Date:	30/11/2012
		Page:	13 of 41

Ip3 (+38.65 MHz)
Ip1 (+38 MHz)
CHB: FSU B
Ip4 (-39.55 MHz)
Ip1 (-40MHz)

Laser Frequency: ν
Frequency shift: $\Delta\nu$
Index of refraction: $n=1$

Definition of the data columns: Relativetime,status,DeltaL_PM,Epsilon_FC,DeltaL_REF, Phi_sum, Phi_FC, Number of samples

Data

Column 1: Time relative to start time in sec
Column 2: Status
Column 3: ΔL_{PM}
Column 4: ϵ_{FC}
Column 5: ΔL_{ref}
Column 6: ϕ_{sum}^{del}
Column 7: ϕ_{FC}^{del}
Column 8: N

Filename: LprmacPhotodiodesYYYY-MM-DDTHH.min.sec.microsec.txt

Header:

Date/Start time: YYYY-MM-DDTHH.MM.SS
acquisition/loop rate
Configuration :

CHA: Instrument
Ip3 (+38.65 MHz)
Ip1 (+38 MHz)
CHB: FSU B
Ip4 (-39.55 MHz)
Ip1 (-40MHz)

Laser Frequency: ν
Frequency shift: $\Delta\nu$
Index of refraction: $n=1$

Definition of the columns:
Relativetime,status,DC_REF_650kHz,DC_REF_450kHz,DC_PROBE_650kHz,DC_PROBE_450kHz,

Data

Column 1: Time relative to start time in sec
Column 2: Status
Column 3: DC_Ref_650kHz
Column 4: DC_Ref_450kHz
Column 5: DC_Probe_650kHz
Column 6: DC_Probe_450kHz

Filename: lprmacFringeYYYY-MM-DDTHH.min.sec.microsec.txt

→ Assess the quality of the PRIMET interferometric signals recorded by the fringe acquisition board connected to lprmac

% Date/Start time: 2010-07-06T17.24.57.460051
% Sampling frequency in Hz: 200
% Configuration:

ESO	Specifications for the PRIMA Metrology data files, data logging and algorithms	Doc:	VLT-SPE-ESO-15736-3899
		Issue:	3
		Date:	30/11/2012
		Page:	14 of 41

```

% CHA: UNDEF
% Ip3 (+38.65 MHz)
% Ip1 (+38.00 MHz)
% CHB: FSU B
% Ip4 (-39.55 MHz)
% Ip2 (-40.00 MHz)
% Laser Frequency (nm): 1319.00
% Frequency Shift (MHz): 78.00
% Index of refraction: n=1
Number of Samples: 20
Definition of the columns:
RelativeTime,DC_REF_450kHz,RMS_REF_450kHz,V_REF_450kHz,DC_REF_650kHz,RMS_REF_650kHz,V_REF_650k
Hz,DC_PROBE_450kHz,RMS_PROBE_450kHz,V__PROBE450kHz,DC_PROBE_650kHz,RMS_PROBE_650kHz,V_PR
OBE_650kHz

```

5.3 Operation with the second phase meter (PRIMET-B) using lprma2

5.3.1 Operation of the PRIMET-B phase meter and Algorithms running on lprma2

All operation schemes presented in section 5.2 are valid for the second phase meter with the following exception:

- The REF650 and PROBE650 inputs of PM2 are both connected to the electrical REF650 generated by PM1. Therefore the status generated by PM2 has a particularity: The status PROBE650 reflects the status of REF650 of PM1 !Therefore,
 - 1/if the optical signal PROBE650 is red on lprmac: it is not red on lprma2
 - 2/if the optical signal REF650 is red on lprmac: both REF650 and PROBE650 will be simulatenously red on lprma2
- the DC level of the photodiodes shall not be considered since the preamplifier board is not used. Consequently, the warnings for low flux or saturation is not relevant.
- *PM Overflow* : occurs if the OPD(ip2-ip4) is larger than 150mm. In the current version of the firmware, after the first PM overflow is detected **all** following samples are flagged as PM overflow (bit7=0). However, the glitch counter of PM overflow (pmacqGui->-B) is kept on-hold (i.e will not increment), otherwise the fitslogs of lprma2 would not cope.
- *FC overflow* : This event should not occur. The corresponding inputs signals of the phase meterB are not used (50Ohm load shunt)

In order to set the error conditions to “nominal” (glitch=pmacq goes in error) or “relaxed (as for PRIMETA-B), one needs to edit “pmacq_lprma2.dbcfg” (under &INTROOT/config/):

<ATTRIBUTE>: useStringentChecks

0-> relaxed

1->nominal

and init/standby/online lprma2

- The formula implemented in lprma2 for computing $\Delta L_2 = IP2 - IP4$ is
$$\frac{c}{2(\nu - f_2)} \cdot \left[\frac{\phi_{sum-digits}}{1024(N+1)} \right]$$

where $f_2 = 40e6$ Hz (see appendix)

5.3.2 Information written by lprma2 on the RMN

- Time stamp with microsec resolution

ESO	Specifications for the PRIMA Metrology data files, data logging and algorithms	Doc:	VLT-SPE-ESO-15736-3899
		Issue:	3
		Date:	30/11/2012
		Page:	15 of 41

- $\Delta L_2=0$ -FSUB=-IP4+IP2” with a 0.1 nm resolution.
- Metrology status

5.3.3 Engineering files written by lprma2

Only the **Lprma2PhaseMeterYYYY-MM-DDTHH.min.sec.txt** as defined in 5.2.3 shall be recorded.

5.4 Automatic Fitslog generated by lprmac and lprma2

Keywords have the format:

ISS.PRI.MET.<keyword>

When necessary, an index “1” is added inside a keyword to refer to the first phase meter (used by lprmac) delivering $\Delta L_1=CHA$ -FSUB. An index “2” refers to the second phase meter (used by lprma2) delivering $\Delta L_2=0$ -FSUB.

Logging during Operation

Keyword	Origin	Value/Type	Logging Period	Comment
DELTAALMEAN	lprmac	%.10f double	30 sec	Mean computed over 30sec
DELTAALSTD	lprmac	%.10f double	30 sec	Standard deviation computed over 30sec
DELTAALMIN	lprmac	%.10f double	30 sec	Minimum over 30 sec
DELTAALMAX	lprmac	%.10f double	30 sec	Maximum over 30 sec
DCREF650MEAN	lprmac	%.2f	30 sec	Mean computed over 30sec
DCREF450MEAN	lprmac	%.2f	30 sec	Mean computed over 30sec
DCPROBE650MEAN	lprmac	%.2f	30 sec	Mean computed over 30sec
DCPROBE450MEAN	lprmac	%.2f	30 sec	Mean computed over 30sec
DCREF650STD	lprmac	%.2f	30 sec	Standard deviation computed over 30sec
DCREF450STD	lprmac	%.2f	30 sec	Standard deviation computed over 30sec
DCPROBE650STD	lprmac	%.2f	30 sec	Standard deviation computed over 30sec
DCPROBE450STD	lprmac	%.2f	30 sec	Standard deviation computed over 30sec
OPDCHBMEAN	lprma2	%.10f double	30 sec	Mean computed over 30sec
OPDCHBSTD	lprma2	%.10f double	30 sec	Standard deviation computed over 30sec
OPDCHBMIN	lprma2	%.10f double	30 sec	Minimum over 30 sec
OPDCHBMAX	lprma2	%.10f double	30 sec	Maximum over 30 sec

Table 2: Automatic fitslog of the phase meter sub-system during operation

Logging on Commands

Keyword	Origin	Value/Type	Logging Period	Comment
REFMET1	lprmac	“Zero type, user parameter , ΔL_{PM} , ϵ_{FC} , L_{FC} , ΔL_{ref} ; $\Delta v,v$ “ String	On REFMET Command	Logged data correspond to the latest values before the REFMET is applied.
REFMET2	Lprma2	“Zero type, user parameter , ΔL_{PM} , ϵ_{FC} , L_{FC} , ΔL_{ref} ; $\Delta v,v$ “ String	On REFMET Command	Logged data correspond to the latest values before the REFMET is applied.
RESET1	lprma2	” ΔL_{PM} , ϵ_{FC} , L_{FC} , ΔL_{ref} ; $\Delta v,v$ “ String	On RESET Command	Logged data correspond to the latest values before the RESET bit appears in the status.

ESO	Specifications for the PRIMA Metrology data files, data logging and algorithms	Doc:	VLT-SPE-ESO-15736-3899
		Issue:	3
		Date:	30/11/2012
		Page:	16 of 41

RESET2	lprma2	" ΔL_{PM} , ϵ_{FC} , L_{FC} , ΔL_{ref} , $\Delta v, v$ " String	On RESET Command	Logged data correspond to the latest values before the RESET bit appears in the status.
--------	--------	---	------------------	---

Table 3: Automatic fitslog of the Phase meter sub-system on commands

Logging on specific events

Keyword	Origin	Value/Type	Logging Period	Event description
DATANOTVALID1	lprmac	"Status bits, DCREF650, DCREF650, DCPROBE650, DCPROBE650" String	On event	Data Not Valid. (Achtung: the status bit is expressed in Hex on the logmonitor !)
PMOVFL1	lprmac	" ΔL_{PM} , ϵ_{FC} , L_{FC} , ΔL_{ref} , $\Delta v, v$ " String	On event	Phase meter Overflow. Logged data correspond to the latest values before the event
FCOVFL1	lprmac	" ΔL_{PM} , ϵ_{FC} , L_{FC} , ΔL_{ref} , $\Delta v, v$ " String	On event	Fringe counter Overflow Logged data correspond to the latest values before the event
WRNGLOWFLUX	lprmac	"Origin,value" String	On event	Warning for low flux
WRNGSAT	lprmac	"Origin,value" String	On event	Warning for saturation
DATANOTVALID2	lprma2	"Status bits, DCREF650, DCREF650, DCPROBE650, DCPROBE650" String	On event	Data Not Valid. (Achtung: the status bit is expressed in Hex on the logmonitor !)
PMOVFL2	lprma2	" ΔL_{PM} , ϵ_{FC} , L_{FC} , ΔL_{ref} , $\Delta v, v$ " String	On event	Phase meter Overflow Logged data correspond to the latest values before the event
FCOVFL2	lprma2	" ΔL_{PM} , ϵ_{FC} , L_{FC} , ΔL_{ref} , $\Delta v, v$ " String	On event	Fringe counter Overflow Logged data correspond to the latest values before the event

Table 4: Automatic fitslog of the Phase-meter sub-system on specific events

5.5 Plot tools

1/ For lprmac

RTDScope:

DELTAL

4xPhotodiode signals

default sampling= 1kHz

default number of samples= 500

Default Y scale= autoscale

label="DeltaL=CHA-FSUB"

"DC Probe650kHz"; "DC Ref650kHz"; "DC Probe450kHz"; "DC Ref650kHz"

"standard plot tool" for long term monitoring

DELTAL on 1 graph

ESO	Specifications for the PRIMA Metrology data files, data logging and algorithms	Doc:	VLT-SPE-ESO-15736-3899
		Issue:	3
		Date:	30/11/2012
		Page:	17 of 41

4xPhotodiode signals on another graph
same labels as above

2/ For lprma2 (photodiode signals are not relevant)

RTDScope:

DELTAL only
default sampling= 1kHz
default number of samples= 500
Default Y scale= autoscale
label="DeltaL=FSUB"

"standard plot tool" for long term monitoring

DELTAL on 1 graph
label same as above

ESO	Specifications for the PRIMA Metrology data files, data logging and algorithms	Doc:	VLT-SPE-ESO-15736-3899
		Issue:	3
		Date:	30/11/2012
		Page:	18 of 41

6 LASER FREQUENCY STABILIZATION SUB-SYSTEM

6.1 Introduction

Two types of laser can be implemented: either the Innolight laser model MIR 500NE-FC (baseline) or the lightwave laser model 125-1319-200. The frequency stabilization algorithm is based on TAC files running on the LCU lprmls. These files are given in RD1

For both Innolight and Lightwave laser, the optical power can be adjusted using the analog output 3 of the MPV955. However, the relation Optical Power versus Voltage is not the same for both lasers.

All temperature set-points (I2, Oven,EOM) are taken from the database

The transmission of the AOM can also be modified per software.

6.2 Operation of the Lightwave laser

Case 1: Lightwave laser model 125-1319-200

(Controller: s/n 610 Laserhead: s/n 3154)

Parameter of the Laser (Query using RS-232)
Model Number and SW Date
Chassis Serial Number
Laser Diode On/Off
Laser Power
Interlock Status
Fault Status
Diode Current Adjust
Diode Power
Laser temperature

Conditions necessary to generate a “laser OK” for the Lightwave laser model 125-1319-200

- *Laser Diode On*
- *Laser Power >150 mW*
- *Interlock status: no interlock*
- *Fault status: No Fault*

If all above conditions are met, a message “**Laser OK**” shall be generated.

In case one of the above conditions is not met, an error message “**Laser Not OK**” shall be generated indicating which condition(s) is not met. (the system goes in state error)

If the “*Laser Temperature*” is out of the range³ $T=40.3^{\circ}\text{C} \pm 0.2^{\circ}\text{C}$, a message “**Laser temperature range exceeded**” shall be generated (indicating also the current laser temperature). $T=40.3^{\circ}\text{C}$ is the default laser temperature used for locking the frequency on the I2 transition P(49)6-6 (see RD1) $\pm 0.2^{\circ}\text{C}$ corresponds to a tuning range of $\pm 500\text{MHz}$ (using the temperature tuning coefficient of $-2.4\text{GHz}/^{\circ}\text{C}$). This indicates if the laser frequency remains inside the selected I2 transition whose total width is 1GHz .

Tuning of the Lightwave laser Power

The power of the Lightwave laser is tuned by applying a voltage between -10 V to 2 V. This setting overrides the Power Adjust signal generated internally by the laser driver. The relation between the output power and the input voltage has been measured (experimental data are available in the test report). According to these measurements, the power can be tuned over the range 53 mW – 170 mW obtained with voltages between -6 V and 2 V. Below -6V the decrease of the input voltage has no effect. To get a power P (W) within this range, one should apply the voltage U_{MPV955}

³ The temperature of $T=40.3$ deg refers to the measured temperature

ESO	Specifications for the PRIMA Metrology data files, data logging and algorithms	Doc:	VLT-SPE-ESO-15736-3899
		Issue:	3
		Date:	30/11/2012
		Page:	19 of 41

$$U_{MPV955} = \frac{P - 0.146}{0.0156}, -6V < U < 2V$$

The power cannot be decreased below 53 mW without switching off the laser.

6.3 Operation of the Innolight laser model MIR 500NE-FC

(Controller: s/n M330g-0414 Laserhead: s/n 1537)

Query using Men AI module 1 and 2 (M36)

Device	Channel	Function
Innolight	+/- I0	Not connected
Diagnostic	+/- I1	Diode laser 1 Power monitor (1V/W), D1
	+/- I2	Diode laser 2 Power monitor (1V/W), D2
	+/- I3	Laser Crystal TEC Error (10V/Deg C)
	+/- I4	Diode laser 1 TEC Error (10V/Deg C)
	+/- I5	Diode laser 2 TEC Error (10V/Deg C)
	+/- I6	Diode laser 1 Temp guard (ctrl loop OK/Not OK)
	+/- I7	Diode laser 2 Temp guard (ctrl loop OK/Not OK)

Connection of the **Module 1 : Differential AI (M36); Channels are counted from 0**

Device	Channel	Function
Innolight	+/- I0	Not connected
Diagnostic	+/- I1	Noise Heater Monitor
	+/- I2	Interlock Monitor

Connection of the **Module 2 : Differential AI (M36); Channels are counted from 0**

The estimation of the laser emitting power is based on the pump diode power monitor voltages D1 and D2 defined in the table above. The laser has been calibrated (AD 8). The estimated laser output power is:

$$P_{estimated} = \frac{(D_1 + D_2)}{2} * \beta + P_1$$

Where $\beta = 1.0211$ and $P_1 = -0.714$ for the Innolight laser head.

Conditions necessary to generate a “laser OK” for the Innolight laser model MIR 500NE-FC

- Diode laser 1 power monitor $>0.7V$ (i.e output power $>150mW$ required to close the frequency stabilization loop)
- Diode laser 2 power monitor $>0.7V$ (i.e output power $>150mW$ required to close the frequency stabilization loop)
- Diode laser 1, Temperature guard (temperature control loop OK)
- Diode laser 2, Temperature guard (temperature control loop OK)
- Noise eater monitor ON
- Interlock status: no interlock

If all above conditions are met, a message “**Laser OK**” shall be generated.

In case one of the above conditions is not met, an error message “**Laser Not OK**” shall be generated indicating which condition(s) is not met (the system goes in state error)

If the “*Laser crystal, TEC error signal*” $> 0.2V$, a message “**Laser temperature range exceeded**” shall be generated (indicating the value of the TEC error signal). Similarly to the lightwave laser, this range corresponds to a tuning range of 500MHz (using the temperature tuning coefficient of $-2.4GHz/^\circ C$). This indicates if the laser frequency remains inside the selected I2 transition whose total width is 1GHz .

ESO	Specifications for the PRIMA Metrology data files, data logging and algorithms	Doc:	VLT-SPE-ESO-15736-3899
		Issue:	3
		Date:	30/11/2012
		Page:	20 of 41

Tuning of the Innolight laser Power:

The power of the Innolight laser is tuned by applying a voltage between 0-10V to the diode current input located on the backside of the laser driver. This analog voltage added to the one set by the knob of the laser driver sets the current in the pump diodes. The knob on the laser driver will be preset to 0. The laser power is therefore entirely defined by the voltage applied to the laser driver Intensity modulation input.

The voltage U(V) is calculated with the following equation:

$$P(W) > 0 \Rightarrow U(V) = \frac{P(W)}{\alpha} + U_0,$$

$$P(W) = 0 \Rightarrow U(V) = 0.$$

where P(W) is the power in W, and $U_0 = 6.955$ and $\alpha = 0.111$ for the Innolight laser head (calibration data are given in AD 8).

U(V) must be limited to the range 0 – 10 V. 10 V corresponds approximately to a current of 1 A in the pump diodes (default setting of the laser).

Warning: all the models presented in this document are valid for a laser cavity temperature of 27.7°C. This temperature allows to reach the required wavelength at high output power (nominal conditions).

How to Switch ON/OFF the Innolight laser by software:

The laser can be remotely switched ON/OFF by opening/closing one input of the diagnostic connector.

This input is connected to a M58 TTL I/O board (module 0, POC0) via a 5 V relay where:

+5V applied to the relay opens the circuit

0V applied to the relay closes the circuit

However, the state of the laser (ON or OFF) and the state of the relay (open/closed) must be known before switching ON or OFF the laser, because the laser can be also manually operated from its driver’s front panel.

The actions to be done to switch on or off the laser are described in the two tables below and valid only if no Interlock had occurred.

To switch ON the laser:

<i>Initial conditions</i>	<i>Diode laser 1 Power monitor Or Diode laser 1 Power monitor < 0.2 V</i>	<i>Diode laser 1 Power monitor Or Diode laser 1 Power monitor > 0.2 V</i>
<i>Circuit opened (0 V applied)</i>	Close relay (apply 5 V)	Close relay (apply 5 V)
<i>Circuit closed (5 V applied)</i>	Open relay (apply 0 V) Wait 2 s Close relay (apply 5 V)	Do nothing

To switch OFF the laser:

First make sure that the frequency stabilization loop is opened (SwitchTemp, SwitchPiezo, TestTacSwitch).

If not, request for confirmation before opening the loop.

Warning message: “Stabilization loop closed; Loop will be opened before switching off the laser; OK-Cancel”

<i>Initial conditions</i>	<i>Diode laser 1 Power monitor Or Diode laser 1 Power monitor < 0.2 V</i>	<i>Diode laser 1 Power monitor Or Diode laser 1 Power monitor > 0.2 V</i>
<i>Circuit opened (0 V applied)</i>	Do nothing	Close relay (apply 5 V) Wait 2 s Open relay (apply 0 V)
<i>Circuit closed (5 V applied)</i>	Open relay (apply 0 V)	Open relay (apply 0 V)

ESO	Specifications for the PRIMA Metrology data files, data logging and algorithms	Doc:	VLT-SPE-ESO-15736-3899
		Issue:	3
		Date:	30/11/2012
		Page:	21 of 41

To switch ON the laser after an Interlock had been detected:

If an Interlock had occurred the procedure to switch the laser back on will not work. Indeed, to switch the laser on to the defined power the current in the pump diode must be measured to determine the offset generated by the knob on the laser driver. This offset which is not zero is reduced to 0 when an interlock takes place and therefore the value of the voltage to be applied to the MPV955 (as described above in Equation 3-4) is biased. The solution for switching ON the laser after an Interlock is simply to apply the following procedure:

- 1) switch ON the laser with the normal procedure described above;
- 2) wait a few seconds;
- 3) Switch OFF the laser with the normal procedure described above;
- 4) wait a few seconds;
- 5) switch ON the laser with the normal procedure described above.

This procedure uses only commands already defined.

6.4 Tuning of the transmission of the AOM's

The light can be attenuated by modulating the power of acoustic wave used in the AOM. This can be done remotely by applying a voltage to the AOM driver (0-1V). This can be done for the four AOM independently. It requires using 4 channels of the MPV955.

The transmission of each AOM has been measured as a function of the input voltage. If the transmission is normalized with respect to its maximum value, the curve can be fitted by the following equation:

$$\tau = 100 \times \sin^2(\alpha U)$$

where τ is the normalized transmission, α parameter of the AOM and U the input voltage.

By default, the AOM should be operated for a maximum transmission, that is to say with an input voltage $U_0 = \pi/(2\alpha)$.

Driver serial /AOM serial /Shift	Channel	Polarization	Ip	MPV 955	α	Default Voltage U_0 (V)
816681/417649/ -40.00MHz	FSUB	s	2	Ch #3	2.3625	0.665
816681/417650 -39.55MHz	FSUB	p	4	Ch #4	2.4114	0.651
816682/417651 38.00MHz	CHA	s	1	Ch #5	2.4244	0.648
816682/417652 38.65MHz	CHA	p	3	Ch #6	1.7796	0.883

From the gui of the stabilization one should be able to modify the value of the transmissions one at a time. The value should be set in % and the corresponding voltage should be calculated and applied to the desired MPV 955 channel (desired AOM driver).

$$U(\tau) = \frac{1}{\alpha} \arcsin\left(\sqrt{\frac{\tau}{100}}\right).$$

ESO	Specifications for the PRIMA Metrology data files, data logging and algorithms	Doc:	VLT-SPE-ESO-15736-3899
		Issue:	3
		Date:	30/11/2012
		Page:	22 of 41

The parameters for the spare drivers are given in the following table:

Driver serial /AOM serial /Shift	Channel	Polarization	Ip	MPV 955	α	Default Voltage $U_0(V)$
823345/417649/ -40.00MHz	FSUB	s	2	Ch #3	2.8113	0.559
823345/417650/ -39.55MHz	FSUB	p	4	Ch #4	2.5438	0.618
823346/417651/ 38.00MHz	CHA	s	1	Ch #5	2.2755	0.609
823346/417652/ 38.65MHz	CHA	p	3	Ch #6	2.3224	0.676

6.5 Automatic procedure to close the frequency stabilization loop:

1. Check with the Wavemeter if the laser is on the “left” side of the transition, i.e. $wlMin = 1319.1777 \text{ nm} < \lambda < wlMax = 1319.1783 \text{ nm}$ (with $wlMin$ and $wlMax$ defined in `pmlss.dbcfg`)
If OK move to step (2), otherwise calculate (with $c = \text{speed of light} = 299792458 \text{ m/s}$):
for Lightwave laser:
 $AOOffset = AOOffset - (c/\lambda_{\text{wavemeter}}(\text{in meters}) - c/(wlNominal))/(2.59 \cdot 10^{-9})$
for Innolight laser:
 $AOOffset = AOOffset + (c/\lambda_{\text{wavemeter}}(\text{in meters}) - c/(wlNominal))/(2.59 \cdot 10^{-9})$
With $wlNominal = 1319.1780 \text{ nm}$ (defined in `pmlss.dbcfg`)
2. Wait 15 sec
3. if $X(\text{Lock-In}) < 0$ move to step (4), otherwise calculate send *autophase* command to lock-in amplifier
4. Go ONLINE with TAC, after 1 sec store the first averaged value from the Power meter as `TestTACConst3`
5. Set the parameter of the “TestTacSwitch” block to 2
6. Wait 1 sec
7. Set the parameter of the “SwitchTemp” block to 2
8. Wait 5 sec
9. Set the parameter of the “SwitchPiezo” block to 2

-> Steps shall be printed on the log monitor !

Stabilization Loop

The frequency stabilization loop shall be considered as successfully closed when the following conditions are met:

- Laser OK
- Temperature range NOT exceeded
- The wavemeter indicates a wavelength λ so that $wlMinStable = 1319.1760 < \lambda < wlMaxStable = 1319.1810$ (query using RS-232). $wlMinStable$ and $wlMaxStable$ are defined in `pmlss.dbcfg`.
- The 25 MHz reference signal is detected by the Lock-in (query using RS-232)
- The command sent to the laser piezo actuator is not saturating: $-5V < V_{\text{piezo}} < 5V$ (read Analog input)
- The command sent to the laser temperature actuator is not saturating: $-10V < V_{\text{piezo}} < 10V$ (read Analog input)
- Based on the desired Laser stabilization precision (ISS PRI MET LSP), the mean error signal (X output of the lock-in⁴) computed over 1 sec is $< V_{\text{lock}}$ (see Table 5)
- Based on the desired Laser stabilization precision (ISS PRI MET LSP), the standard deviation of the error signal (X output of the lock-in) computed over 1 sec is $< V_{\text{lock}}$. (see Table 5)

⁴ The X_{output} of the lock-in corresponds to the rms amplitude of the detector signal. Using a lock-in sensitivity of 100mV (i.e 100mV on the detector=10V at the output of the lock-in), $X_{\text{output}} = 100 \cdot X_{\text{detector_rms}}$. See **Error! Reference source not found.** for details.

ESO	Specifications for the PRIMA Metrology data files, data logging and algorithms	Doc:	VLT-SPE-ESO-15736-3899
		Issue:	3
		Date:	30/11/2012
		Page:	23 of 41

The Laser Stabilization Precision can only take the 3 possible values shown in Table 5. Any other value shall be rejected. The default Laser Stabilization Precision shall be 1.e-8.

ISS PRI MET LSP. Laser stabilization precision $\Delta L/L = \Delta v/v$	Precision on the differential OPD	Δv at $\lambda=1319$ nm	$\Delta \lambda$ at $\lambda=1319$ nm	Lock-in Output ⁵ V_{lock}
No stabilization	-	Laser free running. Typically: 50MHz/hour	-	-
Fine: 1.e-8	0.6 nm at 60mm	2.2745 MHz	0.00001319 nm	0.0569 V
Medium: 1.e-7	6 nm at 60nm	22.745 MHz	0.0001319 nm	0.569 V
Coarse: 1.e-6	60nm at 60mm	227.45 MHz	0.001319 nm	5.69 V

Table 5: Interpretation of the Laser Stabilization Precision (selectable by the instrument)

If all above conditions are met, a message “**Laser Frequency Loop Stable**” shall be generated. In case one of the above condition is not met, an error message “**Laser Frequency Loop Unstable**” shall be generated indicating which condition(s) is not met.

Note: After switching on the laser (cold start up) it is necessary to wait ½ hour before the laser internally stabilizes (output power, polarization state, frequency). Then the frequency stabilization loop can be closed. Again, it will take another 10 to 15 min before the loop can fulfill the conditions “frequency loop stable”. The piezo command will initially saturate until it is desaturated by the temperature command.

The frequency stabilization system will nominally lock the laser around an absolute mean value of 1319.1762 nm

6.6 Operation of the laser in the simplified mode, possibility to ignore devices

To close the frequency stabilization loop requires the simultaneous use of many devices. In many cases, for engineering work the laser can be used without the frequency stabilization system. For that purpose, the laser module software can be operated in a simplified configuration which does not allow closing the loop but requires a limited number of hardware and software features. In that mode the temperature controllers, lock-in amplifier, powermeter and wavemeter can be ignored and the system can be put ONLINE even if one(all) of them is(are) missing. In the normal mode, the failure to communicate with one of this device puts the system in ERROR state.

To operate in the simplified mode the pmlss.dbcfg configuration file, located in \$INTROOT/config/, must be modified. At the end of the file one can find the following lines:

```

<ATTRIBUTE>: ignoreWaveMeter
1
<ATTRIBUTE>: ignorePowerMeter
1
<ATTRIBUTE>: ignoreSR844
1
<ATTRIBUTE>: ignoreCN77000
1

```

For each of the devices the value 0 indicates that it is not ignored (its absence will put the system in the ERROR state), the value 1 indicates that the device is ignored. On the right side of the gui, red flags indicate which devices are ignored. **When**

⁵ Based on the data given in p.21 of VLT-TRE-ESO-15731-3884: Slope of error signal (at the output of the detector) for P=12µW. This corresponds to 25V/GHz at the output of the lock-in for a sensitivity of 100mV. Therefore a frequency shift of <2 MHz (spec.) corresponds to 0.05V at the output of the lock-in amplifier

ESO	Specifications for the PRIMA Metrology data files, data logging and algorithms	Doc:	VLT-SPE-ESO-15736-3899
		Issue:	3
		Date:	30/11/2012
		Page:	24 of 41

one of these devices is ignored it is not possible to close the frequency stabilization loop. An error is generated but the system remains in his previous state.

6.7 Engineering file

Objectives: save data to assess the performance of the stabilization system
Acquisition frequency and length: user selectable

Filename: MetFreqStabYYYY-MM-DDTHH.min.sec.txt

Header:

```
Date/Start time: 2011-07-11T20.04.53
TAC filename: pmlss_IL.tac
Loop status: CLOSED
Wavelength: 1319.1778
Laser diagnostic: Laser OK
DC set. temp: 49.50
DC act. temp: 49.60
EOM set. temp: 30.00
EOM act. temp: 37.10
I2 set. temp: 70.00
I2 act. temp: 70.00
Lock-in ref. detected/frequency: 24999600.0000000000
Lock-in sensitivity: 100 mVrms / -7 dBm
Lock-in filter slope: 12 db/oct
Lock-in output Ch1: -0.072021484
Lock-in output Ch2: -6.899108887
Number of Samples: 18866
Definition of the columns:
RelativeTime, errorSignalX, phaseSignalY, tempCmd, piezoCmd, pmChannelA, pmChannelB
```

Data:

Column 1: time relative to start date/time in sec
Column 2: Error signal (X)
Column 3: Phase signal (Y)
Column 4: Temperature Command (= offset value only if open loop) in V
Column 5: Piezo Command (0 if open loop) in V
Column 6: Second Harmonic relative optical power in V('0' if not connected))
Column 6: IR relative optical power in V('0' if not connected))

In addition a separated file **MetFreqStabYYYY-MM-DDTHH.min.sec.TAC** shall be generated. It will contain all TAC parameters of the stabilization loop.

ACHTUNG:

- the TAC files pmlssXX.TAC and the associated MetFreqStabXX?.tac can show different block numbers !! The source code does not contain block number:
 - MetFreqStabXX?.tac: is created after each STOPMET
 - pmlssXX.TAC: created when pmlss module is installed

ESO	Specifications for the PRIMA Metrology data files, data logging and algorithms	Doc:	VLT-SPE-ESO-15736-3899
		Issue:	3
		Date:	30/11/2012
		Page:	25 of 41

6.8 Automatic Fitslog

Keywords have the format:
ISS.PRI.MET.<keyword>

Logging during Operation

Keyword	Origin	Value/Type	Logging Period	Comment
ERRORSIGNALXMAX	lprmls /AI	%.3f	30 sec	computed over 30sec
ERRORSIGNALXMIN	lprmls /AI	%.3f	30 sec	computed over 30sec
ERRORSIGNALXMEAN	lprmls /AI	%.3f	30 sec	computed over 30sec
ERRORSIGNALXSTD	lprmls /AI	%.3f	30 sec	computed over 30sec
PHASESIGNALYMAX	lprmls /AI	%.2f	30 sec	computed over 30sec
PHASESIGNALYMIN	lprmls /AI	%.2f	30 sec	computed over 30sec
PHASESIGNALYMEAN	lprmls /AI	%.2f	30 sec	computed over 30sec
PHASESIGNALYSTD	lprmls /AI	%.2f	30 sec	computed over 30sec
TEMPCMDMAX	lprmls /AI	%.3f	30 sec	computed over 30sec
TEMPCMDMIN	lprmls /AI	%.3f	30 sec	computed over 30sec
TEMPCMDMEAN	lprmls /AI	%.3f	30 sec	computed over 30sec
TEMPCMDSTD	lprmls /AI	%.3f	30 sec	computed over 30sec
PIEZOCMDMAX	lprmls /AI	%.3f	30 sec	computed over 30sec
PIEZOCMDMIN	lprmls /AI	%.3f	30 sec	computed over 30sec
PIEZOCMDMEAN	lprmls /AI	%.3f	30 sec	computed over 30sec
PIEZOCMDSTD	lprmls /AI	%.3f	30 sec	computed over 30sec
WAVELENGTH	lprmls /ISER12	%.4f	10min	
POWER		%.1f	10min	Laser output power
EOMACTTEMP	lprmls /ISER12	%.2f	10min	EOM Actual temperature
OVENACTTEMP	lprmls /ISER12	%.2f	10min	
I2ACTTEMP	lprmls /ISER12	%.2f	10min	
POWERIRMEAN	lprmls /ISER12		10min	IR (1319nm) power measured after the doubling crystal Average over 5 sec
POWERREDMEAN	lprmls /ISER12		10min	Second harmonic (Red ,659nm) power measured before the I2 cell Average over 5 sec

Table 6: Automatic fitslog of the stabilization sub-system during operation

Logging on Commands

Keyword	Origin	Value/Type	Logging Period	Comment
EOMSETTEMP	lprmls /ISER12	%.2f	On INIT Command	EOM SET temperature
OVENSETTEMP	lprmls /ISER12	%.2f	On INIT Command	
I2SETTEMP	lprmls /ISER12	%.2f	On INIT Command	
AOMSETTRANS4000	lprmls/MPV955	Integer	On INIT Command	Transmission in % of AOM connected to FSUB ip2

ESO	Specifications for the PRIMA Metrology data files, data logging and algorithms	Doc:	VLT-SPE-ESO-15736-3899
		Issue:	3
		Date:	30/11/2012
		Page:	26 of 41

AOMSETTRANS3955	lprmls/MPV955	Integer	On INIT Command	Transmission in % of AOM connected to FSUB ip4
AOMSETTRANS38	lprmls/MPV955	Integer	On INIT Command	Transmission in % of AOM connected to FSUB ip1
AOMSETTRANS3865	lprmls/MPV955	Integer	On INIT Command	Transmission in % of AOM connected to CHA ip3
SR844SENSITIVITY	lprmls /ISER12	%.2f	On INIT Command	
SR844SENSITIVITY	lprmls /ISER12	%.2f	On INIT Command	
SR844TIMECONSTANT	lprmls /ISER12	%.2f	On INIT Command	
SR844FILTERSLOPE	lprmls /ISER12	%.2f	On INIT Command	
AOMTRANS4000	Lprmls/MPV955	string	On SETAOMT Command	Transmission in % of AOM connected to FSUB ip2
AOMTRANS3955			On SETAOMT Command	Transmission in % of AOM connected to FSUB ip4
AOMTRANS38			On SETAOMT Command	Transmission in % of AOM connected to FSUB ip1
AOMTRANS3865			On SETAOMT Command	Transmission in % of AOM connected to CHA ip3
LASERPOWER	lprmls/ISER12 or men	Power, %.3f	On SETPWR Command	For innolight: (D1+D2)/2 For lightwave: Diode power
LOOPPARAM	lprmlss	string	On CLSLOOP Command	Store TAC parameters
AUTOPHASE	lprmlss	time in microsec	On AUTOPHAS Command	

Table 7: Automatic fitslog of the stabilization system on commands

Logging on specific events

Keyword	Origin	Value/Type	Logging Period	Event description
LIGHTWAVENOTOK	lprmls	Origin of problem, String Laser DiodeOff or/and Low Power Interlock Fault	On event	Warning Laser Not OK using the lightwave laser
INNOLIGHTNOTOK	lprmls	Origin of problem, String Low diode1 power or/and Low diode2 power Diode1 temp guard Diode2 temp guard Noise eater Interlock		Warning Laser Not OK using the Innolight laser
LIGHTWAVETEMP	lprmls	Laser temp (DEG) , %.2f		Warning Temp.range exeeded using the lightwave laser
INNOLIGHTTECERROR	lprmls	Diode1 TEC Error(V) , Diode2 TEC Error(V) %.2f		Temp.range exeeded using the Innolight laser
FREQLOOPUNSTABLE	lprmls	Origin of problem,		Laser frequency loop unstable

ESO	Specifications for the PRIMA Metrology data files, data logging and algorithms	Doc:	VLT-SPE-ESO-15736-3899
		Issue:	3
		Date:	30/11/2012
		Page:	27 of 41

		String Laser Not OK or/and Temp Range exceeded Wavelength out of range No Lock-in Ref signal Piezo command saturating Temp Command saturating Mean Error out of range Std Error out of range		
--	--	--	--	--

Table 8: Automatic fitslog of the stabilization system on specific events

6.9 Plot tools

RTDSCOPE:

Signals to be displayed

Error Signal X

Piezo Command

Temperature Command

default sampling= sampling frequency of the laser stabilization = 1kHz

default number of samples= 500

Default Y scale= autoscale

labels: same as signal names above.

6.10 Annotated example of pmlss.dbcfg file

See 9.3 Annotated example of pmlss.dbcfg

7 PUPIL TRACKING SUB- SYSTEM

See algorithm and data logging defined in AD 3

The main parameters of the database configuration (pmpsd.dbcfg) are explained in appendix.

8 INFORMATION PASSED TO ISS

TABLE 1

Definition of the Header

Keyword	Unit	Example	Description
(S) EXTNAME		'METROLOGY_DATA'	Extension name
(S) ISS.DID		Data dictionary name	
(S) ISS.ID		ISS software version string	
(D) C	m/s	299 792 458	Speed of light in meter/s
(D) INDREF		1.00	Index of refraction
(D) LASER_F	Hz	2.2728768600e+014	Calibrated Laser Frequency in Hz (with lowest digit=100kHz). The laser wavelength, λ , can be computed using: $=C/LASER_FREQ/INDREF$
(D) F_SHIFT	Hz	78e6	Frequency shift between the metrology channels
(S) DEV650		Instrument	Channel A of PRIMET (650 kHz) connected to Device connected to Device FSUA, MIDI or AMBER considered as instruments

ESO	Specifications for the PRIMA Metrology data files, data logging and algorithms	Doc:	VLT-SPE-ESO-15736-3899
		Issue:	3
		Date:	30/11/2012
		Page:	28 of 41

(S) IP3865		Ip3	VLTI Input Channel connected to +38.65MHz
(S) IP3800		Ip1	VLTI Input Channel connected to +38MHz
(S) DEFOPDA		Ip3-Ip1	Definition of positive OPD for Channel A
(S) DEV450		FSUB	Channel B of PRIMET (450 kHz) connected to Device FSUB. Channel used for Phase Meter error compensation
(S) IP3955		Ip4	VLTI Input Channel connected to -39.55 MHz
(S) IP4000		Ip2	VLTI Input Channel connected to -40 MHz
(S) DEFOPDB		Ip4-Ip2	Definition of positive OPD for Channel B
(S) DEF_DELTAL		Instrument -OPDFSUB	Definition of positive Differential OPD measured by lprmac

Table columns:

Time, DELTA_L, Status (lprmac)

TABLE 2

Definition of the Header

Keyword	Unit	Example	Description
(S) EXTNAME		'METROLOGY_DATA_FSUB'	Extension name
(S) ISS.DID		Data dictionary name	
(S) ISS.ID		ISS software version string	
(D) C	m/s	299 792 458	Speed of light in meter/s
(D) INDREF		1.00	Index of refraction
(D) LASER_F	Hz	2.2728768600e+014	Calibrated Laser Frequency in Hz (with lowest digit=100kHz). The laser wavelength, λ , can be computed using: $=C/LASER_FREQ/INDREF$
(D) F_SHIFT	Hz	78e6	Frequency shift between the metrology channels
(S) DEV650		Instrument	Channel A of PRIMET (650 kHz) connected to Device connected to Device FSUA, MIDI or AMBER considered as instruments
(S) IP3865		Ip3	VLTI Input Channel connected to +38.65MHz
(S) IP3800		Ip1	VLTI Input Channel connected to +38MHz
(S) DEFOPDA		Ip3-Ip1	Definition of positive OPD for Channel A
(S) DEV450		FSUB	Channel B of PRIMET (450 kHz) connected to Device FSUB. Channel used for Phase Meter error compensation
(S) IP3955		Ip4	VLTI Input Channel connected to -39.55 MHz
(S) IP4000		Ip2	VLTI Input Channel connected to -40 MHz
(S) DEFOPDB		Ip4-Ip2	Definition of positive OPD for Channel B
(S) DEF_DELTAL		0 -OPDFSUB	Definition of pseudo Differential OPD measured by lprma2

Table 2

Table columns:

Time, DELTA_L, Status (lprma2)

ESO	Specifications for the PRIMA Metrology data files, data logging and algorithms	Doc:	VLT-SPE-ESO-15736-3899
		Issue:	3
		Date:	30/11/2012
		Page:	29 of 41

While operating pRIMEt in the “relaxed” error condition mode during commissioning, the following keywords have been added:

```

HIERARCH ESO ISS PRI MET NGLITAB END= 0 / Number of metrology A-B glitches a
HIERARCH ESO ISS PRI MET NGLITAB START= 0 / Number of metrology A-B glitches a
HIERARCH ESO ISS PRI MET NGLITAB200K END= 0 / Number of metrology A-B glitches 2
HIERARCH ESO ISS PRI MET NGLITAB200K START= 0 / Number of metrology A-B glitches
HIERARCH ESO ISS PRI MET NGLITAB45KP END= 0 / Number of metrology A-B glitches 4
HIERARCH ESO ISS PRI MET NGLITAB45KP START= 0 / Number of metrology A-B glitches
HIERARCH ESO ISS PRI MET NGLITAB45KR END= 0 / Number of metrology A-B glitches 4
HIERARCH ESO ISS PRI MET NGLITAB45KR START= 0 / Number of metrology A-B glitches
HIERARCH ESO ISS PRI MET NGLITAB65KP END= 0 / Number of metrology A-B glitches 6
HIERARCH ESO ISS PRI MET NGLITAB65KP START= 0 / Number of metrology A-B glitches
HIERARCH ESO ISS PRI MET NGLITAB65KR END= 0 / Number of metrology A-B glitches 6
HIERARCH ESO ISS PRI MET NGLITAB65KR START= 0 / Number of metrology A-B glitches
HIERARCH ESO ISS PRI MET NGLITABFC0 END= 0 / Number of metrology A-B glitches F
HIERARCH ESO ISS PRI MET NGLITABFC0 START= 0 / Number of metrology A-B glitches
HIERARCH ESO ISS PRI MET NGLITABPLLL END= 0 / Number of metrology A-B glitches P
HIERARCH ESO ISS PRI MET NGLITABPLLL START= 0 / Number of metrology A-B glitches
HIERARCH ESO ISS PRI MET NGLITABPMO END= 0 / Number of metrology A-B glitches P
HIERARCH ESO ISS PRI MET NGLITABPMO START= 0 / Number of metrology A-B glitches
HIERARCH ESO ISS PRI MET NGLITABRST END= 0 / Number of metrology A-B reset coun
HIERARCH ESO ISS PRI MET NGLITABRST START= 0 / Number of metrology A-B reset cou
HIERARCH ESO ISS PRI MET NGLITABTRIG END= 0 / Number of metrology A-B glitches t
HIERARCH ESO ISS PRI MET NGLITABTRIG START= 0 / Number of metrology A-B glitches
HIERARCH ESO ISS PRI MET NGLITB END= 0 / Number of metrology -B glitches at
HIERARCH ESO ISS PRI MET NGLITB START= 0 / Number of metrology -B glitches at
HIERARCH ESO ISS PRI MET NGLITB200K END= 0 / Number of metrology -B glitches 20
HIERARCH ESO ISS PRI MET NGLITB200K START= 0 / Number of metrology -B glitches 2
HIERARCH ESO ISS PRI MET NGLITB45KP END= 0 / Number of metrology -B glitches 45
HIERARCH ESO ISS PRI MET NGLITB45KP START= 0 / Number of metrology -B glitches 4
HIERARCH ESO ISS PRI MET NGLITB45KR END= 0 / Number of metrology -B glitches 45
HIERARCH ESO ISS PRI MET NGLITB45KR START= 0 / Number of metrology -B glitches 4
HIERARCH ESO ISS PRI MET NGLITB65KP END= 0 / Number of metrology -B glitches 65
HIERARCH ESO ISS PRI MET NGLITB65KP START= 0 / Number of metrology -B glitches 6
HIERARCH ESO ISS PRI MET NGLITB65KR END= 0 / Number of metrology -B glitches 65
HIERARCH ESO ISS PRI MET NGLITB65KR START= 0 / Number of metrology -B glitches 6
HIERARCH ESO ISS PRI MET NGLITBFC0 END= 0 / Number of metrology -B glitches FC
HIERARCH ESO ISS PRI MET NGLITBFC0 START= 0 / Number of metrology -B glitches FC
HIERARCH ESO ISS PRI MET NGLITBPLLL END= 0 / Number of metrology -B glitches PL
HIERARCH ESO ISS PRI MET NGLITBPLLL START= 0 / Number of metrology -B glitches P
HIERARCH ESO ISS PRI MET NGLITBPMO END= 189687 / Number of metrology -B glitches
HIERARCH ESO ISS PRI MET NGLITBPMO START= 0 / Number of metrology -B glitches PM
HIERARCH ESO ISS PRI MET NGLITBRST END= 0 / Number of metrology -B reset count
HIERARCH ESO ISS PRI MET NGLITBRST START= 0 / Number of metrology -B reset count
HIERARCH ESO ISS PRI MET NGLITBTRIG END= 0 / Number of metrology -B glitches tr
HIERARCH ESO ISS PRI MET NGLITBTRIG START= 0 / Number of metrology -B glitches t

```

The keywords indicate the value of each status counter of the phase meters at the “Start” and the “end” of the PACMAN exposure.

ESO	Specifications for the PRIMA Metrology data files, data logging and algorithms	Doc:	VLT-SPE-ESO-15736-3899
		Issue:	3
		Date:	30/11/2012
		Page:	30 of 41

9 APPENDIX

9.1 Phase meter performance summary

Phase resolution / Range	
Differential phase	Resolution: $2\pi/1024$ or 0.6 nm Range: $2^{29} \cdot 659.5 \text{ nm}/1024 = 346 \text{ nm}$
Phase compensation	2π or 659.5 nm Range: $2^{24} \cdot 659.5 \text{ nm} = 11 \text{ m}$
Sampling frequency	
Internal (instantaneous phase)	200 kHz
External (accumulated phase)	0.36 Hz–15 kHz
Maximum OPL speed of DL and DDL ($v_{\text{OPL,max}} = \lambda \cdot \Delta\nu/2$)	
DL	
Specs: 450, 650 kHz \pm 55 kHz	$\pm 36 \text{ mm/s}$
As built: 450, 650 kHz \pm 75 kHz	$\pm 49 \text{ mm/s}$
DDL	
Specs: 200 kHz \pm 27.5 kHz	$\pm 18 \text{ mm/s}$
As built: 200 kHz \pm 34.5 kHz	$\pm 23 \text{ mm/s}$
Noise of the photodetectors	
-128 dBm/Hz or $\text{NEP} = 0.14 \text{ pW}/\sqrt{\text{Hz}}$	
Phase difference introduced by the bandpass filters (p. 23)	
$< 0.42 \text{ deg}$ or $2\pi/857$ or 0.8 nm (peak).	
Noise level of the digital phasemeter (p. 29) (for 7 nW equivalent optical power, rms over 50 Hz–50 kHz.)	
0.8 dig or $2\pi/1280$ or 0.5 nm.	
Phase difference introduced by the movement of the DL (including the phase difference introduced by the bandpass filters, see above)	
Phasemeter "Spare 1"	$2\pi/256$ or 2.6 nm (limited by the set-up)
Phasemeter "Spare 2"	$2\pi/426$ or 1.5 nm
Accuracy	
$2\pi/800$ or 0.8 nm (rms) over OPL = 180 mm.	

Note: the metrology is not intended to follow the DL during pre-setting (i.e. for $V_{\text{OPL}} = 1 \text{ m/s}$)

(analysis for error compensation; effect of AOM stability; limitations for long term ΔL monitoring)

ESO	Specifications for the PRIMA Metrology data files, data logging and algorithms	Doc:	VLT-SPE-ESO-15736-3899
		Issue:	3
		Date:	30/11/2012
		Page:	31 of 41

9.2 Estimation of ΔL from the raw phase meter data

9.2.1 Configuration:

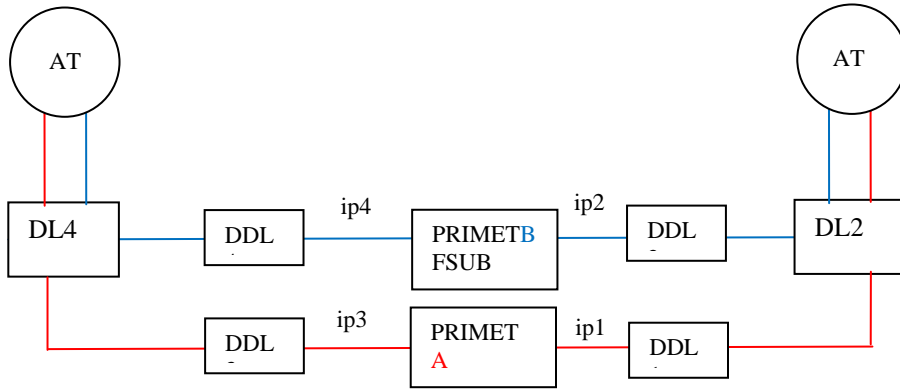

ν =Laser frequency

Channel A (FSUA)		Channel B (FSU B)	
IP3	IP1	IP4	IP2
$\nu+f_3$ $f_3=38.65\text{MHz}$	$\nu+f_1$ $f_1=38\text{MHz}$	$\nu-f_4$ $f_4=39.55\text{MHz}$	$\nu-f_2$ $f_2=40\text{MHz}$
$f_a = 650\text{kHz}$ $\text{OPD}_a = \text{IP3} - \text{IP1} > 0$		$f_b = 450\text{kHz}$ $\text{OPD}_b = \text{IP4} - \text{IP2} > 0$ (also used for phase compensation)	
$\Delta\nu = 78\text{MHz}$			
$f_a - f_b = 200\text{kHz}$ $\Delta L = \text{OPD}_a - \text{OPD}_b > 0$ or $\Delta L = \text{IP3} - \text{IP1} - \text{IP4} + \text{IP2}$			

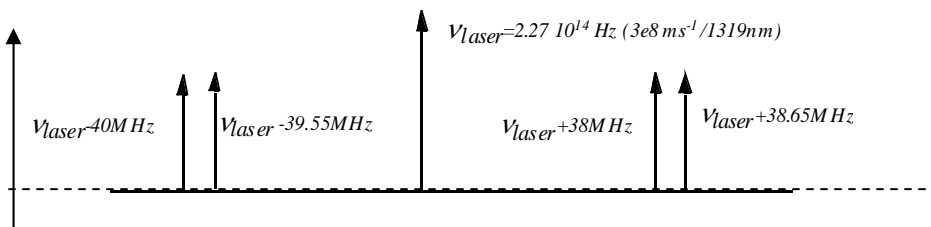

In each interferometric arm, the phase variation is:

$$\phi_3 = k \cdot (\nu + f_3) \cdot D_{ip3}$$

$$\phi_1 = k \cdot (\nu + f_1) \cdot D_{ip1}$$

$$\phi_4 = k \cdot (\nu - f_4) \cdot D_{ip4}$$

$$\phi_2 = k \cdot (\nu - f_2) \cdot D_{ip2}$$

Where $k = 4\pi/c$ (returned way: $2\pi \rightarrow \lambda/2$)

and D_{ip} the variation of OPL in each ip's

ESO	Specifications for the PRIMA Metrology data files, data logging and algorithms	Doc:	VLT-SPE-ESO-15736-3899
		Issue:	3
		Date:	30/11/2012
		Page:	32 of 41

9.2.2 Differential OPD estimated from the phase meter connected to lprmac

9.2.2.1 Case 1: DDL1 tracking (normal mode) and DL4 tracking

DDL2, DDL3, DDL4 and DL2 are fixed;

Ip3->follows ip4: OPL changes by D4>0: $\phi_3 = k \cdot (v + f_3) \cdot D4$

Ip1-> OPL changes by DD1>0: $\phi_1 = k \cdot (v + f_1) \cdot DD1$

Ip4->OPL changes by D4>0: $\phi_4 = k \cdot (v - f_4) \cdot D4$

Ip2-> no changes: $\phi_2 = 0$

$$\begin{aligned} \Delta\phi &= (\phi_3 - \phi_1) - (\phi_4 - \phi_2) \\ &= k \cdot (v + f_3) \cdot D4 - k \cdot (v + f_1) \cdot DD1 - k \cdot (v - f_4) \cdot D4 \\ &= k \cdot (f_3 + f_4) \cdot D4 - k \cdot (v + f_1) \cdot DD1 \end{aligned}$$

We want to estimate the differential OPD: DD1

$$DD1 = 1/(v + f_1) \cdot [(f_3 + f_4) \cdot D4 - \Delta\phi/k]$$

- $\Delta\phi$ (rad) is calculated from the summed phase, ϕ_{sum} (in digits), delivered by the phase meter connected to Lprmac
 $\Delta\phi(\text{rad}) = \phi_{sum}(\text{digits}) \cdot 2\pi/1024/(N+1)$
- D4 is calculated from the “error compensation fringe counter” of lprmac ϕ_{FC} (in digits). The fringe counter is generated by counting the fringes Ref450-Probe450=ip2-ip4. The measured phase in rad is
 $(\phi_{ip2} - \phi_{ip4}) = \phi_{FC}(\text{digits}) \cdot 2\pi = 4\pi/c \cdot (v - f_4) \cdot (-D4)$ leading to $D4 = -\phi_{FC} \cdot c/2/(v - f_4)$

$$DD1 = \frac{1}{(v + f_1)} \cdot \left[-(f_3 + f_4) \cdot \phi_{FC} \cdot \frac{c}{2(v - f_4)} - \frac{\phi_{sum} \cdot 2\pi}{1024(N + 1)} \cdot \frac{c}{4\pi} \right]$$

This can be rewritten:

$$DD1 = -\frac{c}{2 \cdot (v + f_1)} \cdot \left[\frac{\phi_{sum}}{1024(N + 1)} + \frac{(f_3 + f_4)}{(v - f_4)} \cdot \phi_{FC} \right]$$

Equation 1

9.2.2.2 Case 2: DDL1 tracking (normal mode) and DL2 tracking

DDL2, DDL3, DDL4 and DL4 are fixed;

Ip3->no changes: $\phi_3 = 0$

Ip1->OPL changes by (DD1+D2): $\phi_1 = k \cdot (v + f_1) \cdot (DD1 + D2)$

Ip4->no changes: $\phi_4 = 0$

Ip2-> OPL changes by D2: $\phi_2 = k \cdot (v - f_2) \cdot D2$

$$\begin{aligned} \Delta\phi &= (\phi_3 - \phi_1) - (\phi_4 - \phi_2) \\ &= -k \cdot (v + f_1) \cdot (DD1 + D2) + k \cdot (v - f_2) \cdot D2 \\ &= -k \cdot (v + f_1) \cdot DD1 - k \cdot (f_1 + f_2) \cdot D2 \end{aligned}$$

DD1 = -1/(v+f1). [(f1+f2).D2+ $\Delta\phi/k$], where

- $\Delta\phi(\text{rad}) = \phi_{sum}(\text{digits}) \cdot 2\pi/1024/(N+1)$

ESO	Specifications for the PRIMA Metrology data files, data logging and algorithms	Doc:	VLT-SPE-ESO-15736-3899
		Issue:	3
		Date:	30/11/2012
		Page:	33 of 41

- $(\phi_{ip2} - \phi_{ip4}) = \phi_{FC(digits)} \cdot 2\pi = 4\pi/c \cdot (v - f_2) \cdot D2$ leading to $D2 = \phi_{FC} \cdot c/2/(v - f_2)$

$$DD1 = -\frac{c}{2 \cdot (v + f_1)} \cdot \left[\frac{\phi_{sum}}{1024(N + 1)} + \frac{(f_1 + f_2)}{(v - f_2)} \phi_{FC} \right]$$

Equation 2

9.2.2.3 Case 3: DDL2 tracking (swap mode) and DL4 tracking

DDL1, DDL3, DDL4 and DL2 are fixed;

Ip3-> OPL changes by D4

$$\phi_3 = k \cdot (v + f_3) \cdot D4$$

Ip1->no changes

$$\phi_1 = 0$$

Ip4-> OPL changes by D4

$$\phi_4 = k \cdot (v - f_4) \cdot D4$$

Ip2-> OPL changes by DD2:

$$\phi_2 = k \cdot (v - f_2) \cdot DD2$$

$$\begin{aligned} \Delta\phi &= (\phi_3 - \phi_1) - (\phi_4 - \phi_2) \\ &= k \cdot (v + f_3) \cdot D4 - k \cdot (v - f_4) \cdot D4 + k \cdot (v - f_2) \cdot DD2 \end{aligned}$$

DD2 = $1/(v - f_2) \cdot [\Delta\phi/k - (f_3 + f_4) \cdot D4]$, where

- $\Delta\phi(\text{rad}) = \phi_{sum(digits)} \cdot 2\pi/1024/(N + 1)$
- $D4 = \phi_{FC} \cdot c/2/(v - f_4)$

$$DD2 = \frac{c}{2 \cdot (v - f_2)} \cdot \left[\frac{\phi_{sum}}{1024(N + 1)} + \frac{(f_3 + f_4)}{(v - f_4)} \phi_{FC} \right]$$

Equation 3

9.2.2.4 Case 4: DDL2 tracking (swap mode) and DL2 tracking

DDL1, DDL3, DDL4 and DL4 are fixed;

Ip3-> no change

$$\phi_3 = 0$$

Ip1-> OPL changes by D2

$$\phi_1 = k \cdot (v + f_1) \cdot D2$$

Ip4-> no change

$$\phi_4 = 0$$

Ip2-> OPL changes by D2+DD2:

$$\phi_2 = k \cdot (v - f_2) \cdot (DD2 + D2)$$

$$\begin{aligned} \Delta\phi &= (\phi_3 - \phi_1) - (\phi_4 - \phi_2) \\ &= -k \cdot (v + f_1) \cdot D2 + k \cdot (v - f_2) \cdot (DD2 + D2) \end{aligned}$$

DD2 = $1/(v - f_2) \cdot [\Delta\phi/k + (f_1 + f_2) \cdot D2]$, where

- $\Delta\phi(\text{rad}) = \phi_{sum(digits)} \cdot 2\pi/1024/(N + 1)$
- $D2 = \phi_{FC} \cdot c/2/(v - f_2)$

$$DD2 = \frac{c}{2 \cdot (v - f_2)} \cdot \left[\frac{\phi_{sum}}{1024(N + 1)} + \frac{(f_1 + f_2)}{(v - f_2)} \phi_{FC} \right]$$

Equation 4

ESO	Specifications for the PRIMA Metrology data files, data logging and algorithms	Doc:	VLT-SPE-ESO-15736-3899
		Issue:	3
		Date:	30/11/2012
		Page:	34 of 41

9.2.2.5 Error analysis

What happens if we use a “generic” formula as shown below which does not disentangle v and $(v-f_i)$?

$$DD = \frac{c}{2 \cdot v} \cdot \left[\frac{\phi_{sum}}{1024(N+1)} + \frac{\Delta v}{v} \phi_{FC} \right], \text{ Where } \Delta v = (f_1 + f_2) = 78 \text{ MHz}$$

Equation 5

This formula does not discriminate the individual frequency shifts based on which DL/DDL are tracking. (PRIMET does not know about this configuration !)

Let's take the case of Equation 3 (case 3) and compute the metrology error (DD-DD2).

This leads to 2 error terms, ϵ_{sum} and ϵ_{FC} , respectively proportional to $\phi_{sum}/1024/(N+1)$ and ϕ_{FC}

$$\epsilon_{sum} = \frac{c}{2 \cdot v} - \frac{c}{2 \cdot (v - f_2)} = \frac{c}{2 \cdot v} \left(1 - \frac{1}{\left(1 - \frac{f_2}{v}\right)} \right) \approx -\frac{c \cdot f_2}{2 \cdot v^2}$$

When DD2 moves by 1 m OPL, $\phi_{sum}/1024/(N+1)$ corresponds to $1\text{m}/(\lambda/2) = 2v/c$ rad

The error amounts to:

$$\epsilon_{sum}^* = \epsilon_{sum} \cdot \frac{2v}{c} = -\frac{f_2}{v} = -176 \text{ nm} / \text{m} \quad (\text{Per meter of OPL created by the DDL})$$

This leads to an error of ~10nm over a DDL OPL stroke of 60mm

Similarly,

$$\epsilon_{FC} = \frac{c}{2 \cdot v} \cdot \frac{\Delta v}{v} - \frac{c}{2 \cdot (v - f_2)} \cdot \frac{(f_3 + f_4)}{(v - f_4)},$$

For a DL OPL motion of 1m, the corresponding error is

$$\epsilon_{FC}^* = \epsilon_{FC} \cdot \frac{2v}{c} = -0.88 \text{ nm} / \text{m} \quad (\text{per meter of OPL created by the DL})$$

or ~8nm for an OPL of 10m

(=33 min of observation if $d\text{OPL}/dt = 5 \text{ mm/s}$)

The amplitude of these errors are valid for all other cases 1,2,4. and sufficiently low for micro-arcsec level astrometry.

9.2.2.6 Conclusion:

- the generic formula can be used in lprmac. This simplifies considerably the operation because PRIMET does not need to know about the PRIMA current operation scenario (which DL/DDL is tracking)
- However, if there is a need in the future to further reduce the metrology errors (especially ϵ_{FC}^* for large DL OPL variations), the LCU could directly provide the raw data ϕ_{sum}, N, ϕ_{FC} in the fits file. Then the exact formula can be used based on the configuration. However, the PRIMET data displayed on the GUI should be computed from Equation 5. The PRIMET engineering files already contains the raw data as well as ΔL from Equation 5

9.2.3 OPD in the B-channel estimated from the phase meter connected to lprma2

The phase meter connected to lprma2 measures

$$\Delta\phi = 0 - (\phi_4 - \phi_2) = \phi_2 - \phi_4$$

$$\phi_4 = k \cdot (v - f_4) \cdot D_{ip4}$$

ESO	Specifications for the PRIMA Metrology data files, data logging and algorithms	Doc:	VLT-SPE-ESO-15736-3899
		Issue:	3
		Date:	30/11/2012
		Page:	35 of 41

$$\phi_2 = k \cdot (v - f_2) \cdot D_{ip2}$$

9.2.3.1 Case 1: D_{ip2} is changing

Ip4->: no changes

$$\phi_4 = 0$$

Ip2-> OPL changes by $D_{ip2} > 0$:

$$\phi_2 = k \cdot (v - f_2) \cdot D_{ip2}$$

$$\Delta\phi = k \cdot (v - f_2) \cdot D_{ip2} \text{ where } \Delta\phi(\text{rad}) = \phi_{\text{sum}(\text{digits})} \cdot 2\pi / 1024 / (N+1)$$

$$D_{ip2} = \frac{c}{2(v - f_2)} \cdot \left[\frac{\phi_{\text{sum-digits}}}{1024(N+1)} \right]$$

The formula currently implemented in PRIMET-B (lprma2) is the same as for PRIMETAB(lprmac)

$$D = \frac{c}{2 \cdot v} \cdot \left[\frac{\phi_{\text{sum}}}{1024(N+1)} + \frac{\Delta v}{v} \phi_{FC-\text{digits}} \right]$$

The “error compensation fringe counter”, ϕ_{FC} (in digits), is also connected on lprmac2. The fringe counter is generated by counting the fringes Ref450-Probe450=ip2-ip4. The measured phase in rad is

$$(\phi_{ip2} - \phi_{ip4}) = \phi_{FC(\text{digits})} \cdot 2\pi = 4\pi / c \cdot (v - f_2) \cdot D_{ip2} - 0$$

$$D = \frac{c}{2 \cdot v} \cdot \left[\frac{\phi_{\text{sum}}}{1024(N+1)} + \frac{\Delta v}{v} \frac{2}{c} (v - f_2) \cdot D_{ip2} \right]$$

Two error components occur:

- ϵ_v : associated to the selection of v instead of $(v - f_2)$ in the formula
- ϵ_{ec} : One associated to the connection of the ‘error compensation fringe counter’, which is actually only relevant for the estimation of the differential OPD with lprmac

ϵ_v is equivalent to ϵ_{sum} defined above, with

$$\left| \epsilon_v^* \right| = \frac{f_2}{v} = 176 \text{ nm} / \text{m} \text{ (per meter of OPL created by DL2)}$$

$$\epsilon_{ec} = \frac{c}{2 \cdot v} \cdot \frac{\Delta v}{v} \cdot \frac{2}{c} (v - f_2) \cdot D_{ip2} = \frac{\Delta v}{v^2} (v - f_2) \cdot D_{ip2}$$

$$\frac{\epsilon_{ec}^*}{D_{ip2}} = \frac{\Delta v}{v^2} (v - f_2) = 343 \text{ nm} / \text{m} \text{ (per meter of OPL created by DL2)}$$

9.2.3.2 Case 2: D_{ip4} is changing

Ip4->OPL changes by $D_{ip4} > 0$:

$$\phi_4 = k \cdot (v - f_4) \cdot D_{ip4}$$

Ip2-> no changes:

$$\phi_2 = 0$$

$$\Delta\phi = -k \cdot (v - f_4) \cdot D_{ip4}, \text{ where } \Delta\phi(\text{rad}) = \phi_{\text{sum}(\text{digits})} \cdot 2\pi / 1024 / (N+1)$$

The same analysis as Case 1 applies except that $(v - f_4)$ is used instead of $(v - f_2)$.

ESO	Specifications for the PRIMA Metrology data files, data logging and algorithms	Doc:	VLT-SPE-ESO-15736-3899
		Issue:	3
		Date:	30/11/2012
		Page:	36 of 41

9.2.3.3 Conclusion:

- The error compensation must be DISCARDED on the phase meter connected to lprma2 and used to estimate ip2-ip4 (also known as PRIMET-B). In addition, the FCin_Probe and FCin_Ref of the digital phase meter may actually be connected to a same 450kHz signal to avoid floating inputs or loaded with 50Ohms resistors.

- The formula implemented in lprma2 shall be
$$D = \frac{c}{2(\nu - f_2)} \cdot \left[\frac{\phi_{sum-digits}}{1024(N+1)} \right]$$

Where $f_2=40e6$ Hz

- There is no need to differentiate the cases where OPL_ip2 is changing (f_2 required) or OPL_ip4 is changing (f_4 required). The associated error is only $\left[\frac{c}{2(\nu - f_2)} - \frac{c}{2(\nu - f_4)} \right] \cdot \frac{2\nu}{c} \approx \frac{(f_2 - f_4)}{\nu^2} \approx 2nm/m$ which below the laser frequency stability and absolute calibration spec.

9.3 Annotated example of pmlss.dbcfg

```

<CWP>: @lte32:pmlss
  <ATTRIBUTE>: simulation
    0
  <ATTRIBUTE>: timeout
    1
  <ATTRIBUTE>: serverName
    "lsfServer"
  <ATTRIBUTE>: monPeriod
    1000
  <ATTRIBUTE>: numDevices
    8
  <POINT>: <relative>control
    <ATTRIBUTE>: deviceTable <TYPE>:
Table <REC>: 0 - 1 <FIELDS>: 0 - 5
    "tac" "softdev" 0 0 0 0
    "monitor" "taskdev" 0 0 0 0
  <POINT>: <relative>control:softdev
    <ATTRIBUTE>: simulation
      0
    <ATTRIBUTE>: timeout
      120
  <POINT>: <relative>control:softdev:tac
    <ATTRIBUTE>: simulation
      0
    <ATTRIBUTE>: timeout
      120
    <ATTRIBUTE>: serverName
      ""
  <POINT>: <relative>control:taskdev
    <ATTRIBUTE>: simulation

```

ESO	Specifications for the PRIMA Metrology data files, data logging and algorithms	Doc:	VLT-SPE-ESO-15736-3899
		Issue:	3
		Date:	30/11/2012
		Page:	37 of 41

<pre> 0 <ATTRIBUTE>: timeout 120 <POINT>: <relative>control:taskdev:monitor <ATTRIBUTE>: simulation 0 <ATTRIBUTE>: timeout 120 <ATTRIBUTE>: startState 4 <ATTRIBUTE>: ignoreStop 1 <ATTRIBUTE>: timerNum -1 <ATTRIBUTE>: period 1000 <ATTRIBUTE>: priority 85 <ATTRIBUTE>: stackSize 30 <ATTRIBUTE>: maxNumOverTime -1 <POINT>: <relative>config <ATTRIBUTE>: rcsId "" <ATTRIBUTE>: i2TempSetpoint 70 <ATTRIBUTE>: dcTempSetpoint 47.5 <ATTRIBUTE>: eomTempSetpoint 30 <ATTRIBUTE>: ignoreWaveMeter 0 <ATTRIBUTE>: ignorePowerMeter 0 <ATTRIBUTE>: ignoreSR844 0 <ATTRIBUTE>: ignoreCN77000 0 <ATTRIBUTE>: aomIp2Alpha 2.3625 <ATTRIBUTE>: aomIp4Alpha 2.4114 <ATTRIBUTE>: aomIp1Alpha 2.4244 <ATTRIBUTE>: aomIp3Alpha 1.7796 <ATTRIBUTE>: aomIp2 100.0 <ATTRIBUTE>: aomIp4 100.0 <ATTRIBUTE>: aomIp1 100.0 </pre>	<p>Defines default temperature setpoint of iodine cell</p> <p>Defines default temperature setpoint of cristal oven</p> <p>Defines default temperature setpoint of EOM</p> <p>0 uses Wavemeter, 1 allows to ignore wavemeter</p> <p>0 uses Wavemeter, 1 allows to ignore powermeter</p>
--	--

ESO	Specifications for the PRIMA Metrology data files, data logging and algorithms	Doc:	VLT-SPE-ESO-15736-3899
		Issue:	3
		Date:	30/11/2012
		Page:	38 of 41

<pre> <ATTRIBUTE>: aomIp3 100.0 <ATTRIBUTE>: useLW125Laser 0 <ATTRIBUTE>: LSPNominalIL 250.0 <ATTRIBUTE>: LSPNominalLW 70.0 <ATTRIBUTE>: serialPortWM "/iser2" <ATTRIBUTE>: serialPortSR "/iser1" <ATTRIBUTE>: serialPortLW "/iser0" <ATTRIBUTE>: serialPortPM "/iser5" <ATTRIBUTE>: serialPortCN "/iser6" <ATTRIBUTE>: lspConf 0.0569 <ATTRIBUTE>: alpha 0.111 <ATTRIBUTE>: U0 6.955 <ATTRIBUTE>: LW125PwrMin 53.0 <ATTRIBUTE>: LW125PwrMax 170.0 <ATTRIBUTE>: ILPwrMin 0.0 <ATTRIBUTE>: ILPwrMax 330.0 <ATTRIBUTE>: beta 1.0211 <ATTRIBUTE>: P1 -0.714 <ATTRIBUTE>: wlNominal 1319.1768 <ATTRIBUTE>: wlMin 1319.1763 <ATTRIBUTE>: wlMax 1319.1773 <ATTRIBUTE>: wlMinStable 1319.1753 <ATTRIBUTE>: wlMaxStable 1319.1773 </pre>	<p>0 uses Wavemeter, 1 allows to ignore SR844 lock-in amplifier</p> <p>0 uses Wavemeter, 1 allows to ignore the three temperature controllers (iodine cell, cristal oven, EOM)</p> <p>Calibration of AOM transmission curve for Ip2</p> <p>Calibration of AOM transmission curve for Ip4</p> <p>Calibration of AOM transmission curve for Ip1</p> <p>Calibration of AOM transmission curve for Ip3</p> <p>Defines AOM of Ip2 default transmission in %</p> <p>Defines AOM of Ip4 default transmission in %</p> <p>Defines AOM of Ip1 default transmission in %</p> <p>Defines AOM of Ip3 default transmission in %</p> <p>0 uses Innolight laser head, 1 uses Lightwave laser head</p> <p>Defines default laser output power for Innolight laser head</p> <p>Defines default laser output power for Lightwave laser head</p> <p>Used in calculation of voltage to be applied to the laser head to obtain a given output power (calibrated for one Innolight</p>
--	---

ESO	Specifications for the PRIMA Metrology data files, data logging and algorithms	Doc:	VLT-SPE-ESO-15736-3899
		Issue:	3
		Date:	30/11/2012
		Page:	39 of 41

	<p>laser head, see 6.3)</p> <p>Lightwave laser head minimum output power setpoint</p> <p>Lightwave laser head maximum output power setpoint</p> <p>Innolight laser head minimum output power setpoint</p> <p>Innolight laser head maximum output power setpoint</p> <p>Used in the estimation of the laser head output power from the pump diode diagnostic voltages (calibrated for one Innolight laser head, see 6.3)</p> <p>Wavelength used as setpoint to make coarse approach of the iodine transition before the loop is closed, see 6.3</p> <p>Defines the range of wavelength over which the loop can be closed, see 6.3</p> <p>Defines the range of wavelength for which the laser wavelength is considered as stable, see 6.3</p>
--	---

ESO	Specifications for the PRIMA Metrology data files, data logging and algorithms	Doc:	VLT-SPE-ESO-15736-3899
		Issue:	3
		Date:	30/11/2012
		Page:	40 of 41

9.4 Annotated example of pmpsd.dbcfg

Location on wprima-> cd \$INTROOT/config

Description of the main parameters used for the pupil tacking loop

Parameter	Description
<ATTRIBUTE>: getBkgAvgTime 5	Time in sec to compute the mean background flux
...	
<ATTRIBUTE>: psdXConvFactor 1.0	Conversion from the raw Xposition in "fraction of the beam radius" to m
<ATTRIBUTE>: psdYConvFactor 1.0	Conversion from the raw Yposition in "fraction of the beam radius" to m
<ATTRIBUTE>: strtmpoWaitTime 3.0	Wait time in sec after closing the loop before assessing if the guiding conditions are fulfilled
<ATTRIBUTE>: rmsPeriod 2	Time in sec over which the rms position deviation is computed
<ATTRIBUTE>: logPeriod 30.0	Period at which the fits keywords are logged
<ATTRIBUTE>: ppoRmsThreshold 0.50	Rms threshold above which the loop is automatically opened
<ATTRIBUTE>: ppoCorrTooLarge 10.0	Controller guiding offset threshold above which the loop is automatically opened
<ATTRIBUTE>: ppoPeriod 0.01	Period at which the corrections are sent to the actuator (STS-VCM)
<ATTRIBUTE>: sampPeriod 0.001	Sampling period of the quadcell signals
<ATTRIBUTE>: psdVtoW 1	Conversion factor (not used)
<ATTRIBUTE>: psdBeamWaist 1.0	Size of the beam wait in m (not used)
<ATTRIBUTE>: psdBeamDetected 1.8	Voltage threshold (sum of the 4 quadrants of each quadcell) above which the beam is considered as detected
<ATTRIBUTE>: psdBeamDetSRCHBM 2	Voltage threshold (sum of the 4 quadrants of each quadcell) above which the beam search is considered as successful.
<ATTRIBUTE>: psdBeamSatPGAOther 39.5	Voltage threshold (sum of the 4 quadrants of each quadcell) above which the beam is considered as saturated
<ATTRIBUTE>: psdBeamSatPGA1 20.0	Voltage threshold (sum of the 4 quadrants of each quadcell) above which the beam is considered as saturated when the PGA gain is set to 1
...	
<ATTRIBUTE>: numPSDs 4	Maximum Number of active PSDs
<ATTRIBUTE>: ipAddressSTSAT1 "192.168.6.25"	IP addresses of the VCM-LCU's of the various telescopes (not yet defined for the UT case)
<ATTRIBUTE>: ipAddressSTSAT2 "192.168.6.35"	
<ATTRIBUTE>: ipAddressSTSAT3 "192.168.6.45"	
<ATTRIBUTE>: ipAddressSTSAT4 "192.168.6.55"	
<ATTRIBUTE>: ipAddressSTSUT1 "xxx.xxx.xxx.xxx"	
<ATTRIBUTE>: ipAddressSTSUT2 "xxx.xxx.xxx.xxx"	
<ATTRIBUTE>: ipAddressSTSUT3 "xxx.xxx.xxx.xxx"	
<ATTRIBUTE>: ipAddressSTSUT4 "xxx.xxx.xxx.xxx"	
...	

ESO	Specifications for the PRIMA Metrology data files, data logging and algorithms	Doc:	VLT-SPE-ESO-15736-3899
		Issue:	3
		Date:	30/11/2012
		Page:	41 of 41

<pre> <ATTRIBUTE>: Q1pmpsdGain 0.02 <ATTRIBUTE>: Q1pmpsdA1 -0.875 <ATTRIBUTE>: Q1pmpsdB1 -1.0 <ATTRIBUTE>: Q1pmpsdA2 0.0 <ATTRIBUTE>: Q1pmpsdB2 0.0 ... <ATTRIBUTE>: Q1convMatA11 -1.0 <ATTRIBUTE>: Q1convMatA12 0.0 <ATTRIBUTE>: Q1convMatA21 0.0 <ATTRIBUTE>: Q1convMatA22 -1.0 <ATTRIBUTE>: loopClosed 1 <ATTRIBUTE>: spiralStepSize 0.05 <ATTRIBUTE>: spiralAmplitude 10 <ATTRIBUTE>: beamDetAmplitude 0.001 <ATTRIBUTE>: beamDetFrequency 10.0 <ATTRIBUTE>: beamDetFilterTau 0.5 <ATTRIBUTE>: beamDetSeconds 0.1 <ATTRIBUTE>: beamDetThreshold1 0.0 <ATTRIBUTE>: beamDetThreshold2 10000.0 <ATTRIBUTE>: Q1PGAGain 10.0 <ATTRIBUTE>: Q1TRAGain 1.0 </pre>	<p>quadcell1 (Q1)-> (AT3-A) -IP1 gain and Ai,Bi parameters of the controller</p> $C = \text{gain} \cdot \frac{1 + a1.z^{-1} + a2.z^{-2}}{1 + b1.z^{-1} + b2.z^{-2}}$ <p>Conversion matrix</p> <p>Similar definition applies for the other quadcells Q2,Q3,Q4 in the dbcfg file (but with other values, see commissioning reports)</p> <p>quadcell2(Q2)-> (AT4-A)-IP3 quadcell3(Q3)-> (AT3-B) -IP2 quadcell4(Q4)-> (AT4-B) -IP4</p> <p>1= the feedback loop is closed 0=the feedback loop is opened (e.g to measure the open loop transfer function)</p> <p>Size of the steps used during beam search</p> <p>Total amplitude of the grid used during the beam search</p> <p>6 Parameters of the PRIMET BTK (not used)</p> <p>Default gain of the PGA amplifiers (second stage) for Q1</p> <p>Default gain of the Transimpedance amplifiers (first stage) for Q1</p>
--	--