



EUROPEAN SOUTHERN OBSERVATORY

Organisation Européenne pour des Recherches Astronomiques dans l'Hémisphère Austral
Europäische Organisation für astronomische Forschung in der südlichen Hemisphäre

ESO - EUROPEAN
SOUTHERN
OBSERVATORY

VERY LARGE TELESCOPE

My Cookbook

Doc. No.: VLT-TRE-ESO-15730-

Issue

Date:

Prepared: S.Leveque/

Name

Date

Signature

Approved:

Name

Date

Signature

Released:

Name

Date

Signature

ESO	Cookbook	Doc:	VLT-TRE-ESO-15730-
		Issue:	1
		Date:	21/7/09
		Page:	2 of 35

CHANGE RECORD

Issue	Date	Affected Paragraphs(s)	Reason/Initiation/Remarks
1		All	First issue

ESO	Cookbook	Doc:	VLT-TRE-ESO-15730-
		Issue:	1
		Date:	21/7/09
		Page:	3 of 35

TABLE OF CONTENTS

1	Lab Configuration.....	4
2	Marcel	5
3	M16	5
4	Laboratory and ARAL TCCD	6
5	DL	8
6	DDL and DOPDC	10
7	FSU	11
8	PACMAN	13
9	RMNMON	14
10	IRIS	14
11	AT-STs.....	16
12	PRIMA recorder etc.....	19
13	ISS.....	19
14	VCM curvatures for the At and DL	22
14.1	AT#4-J2 DL#4.....	22
14.2	AT#3-G2 DL#2	28
14.3	Summary DI-VCM ROC for OPL=14m obtained after ACOM1	31
14.4	AT#3-A1-DL#??.....	32
15	Field orientation on the AT-TCCD	33
16	Unix pour les nuls and useful commands.....	33

1 LAB CONFIGURATION

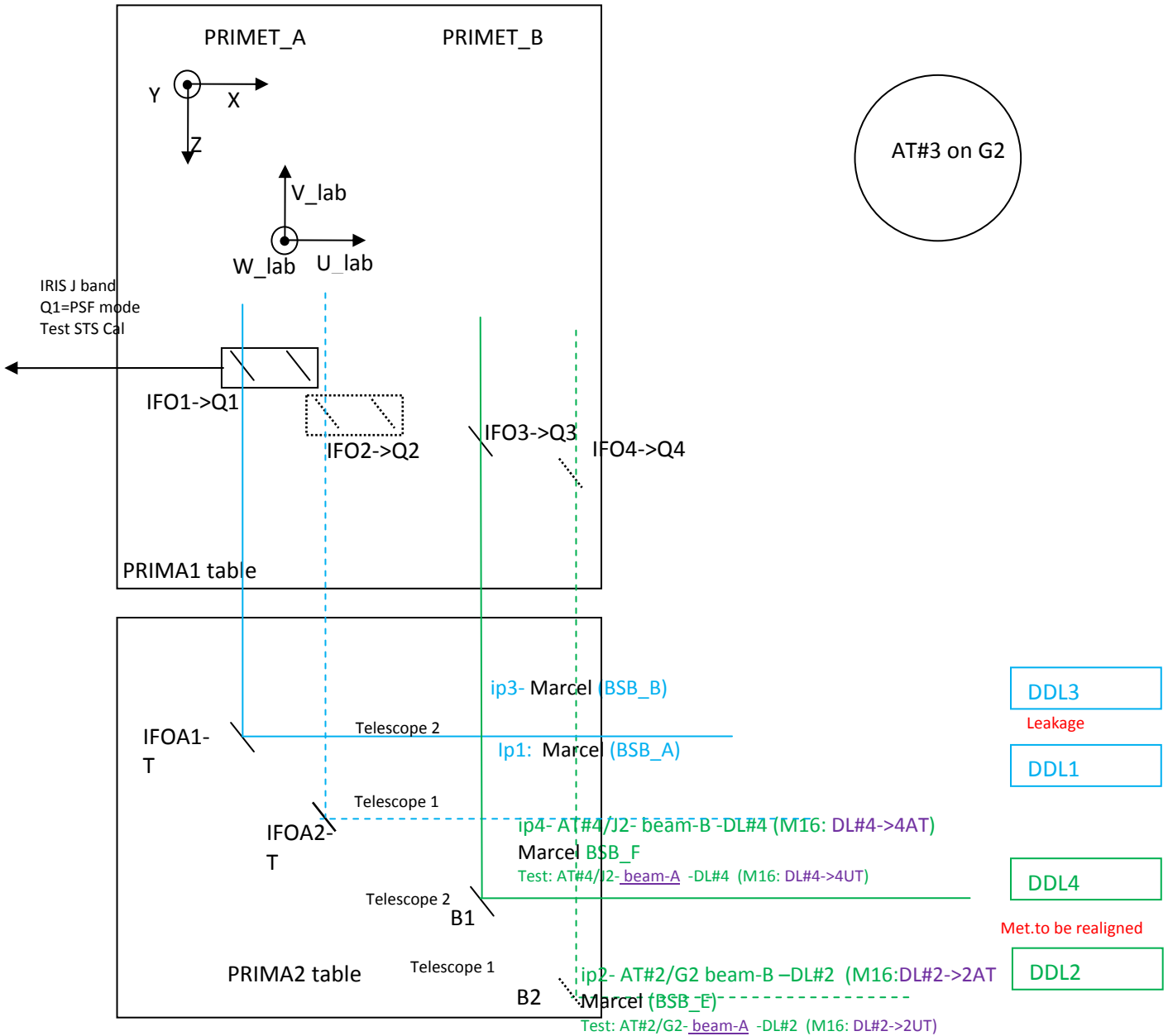

Figure 1: Beam routing.

ESO	Cookbook	Doc:	VLT-TRE-ESO-15730-
		Issue:	1
		Date:	21/7/09
		Page:	5 of 35

2 MARCEL

Configuration done under waral
aripanControl

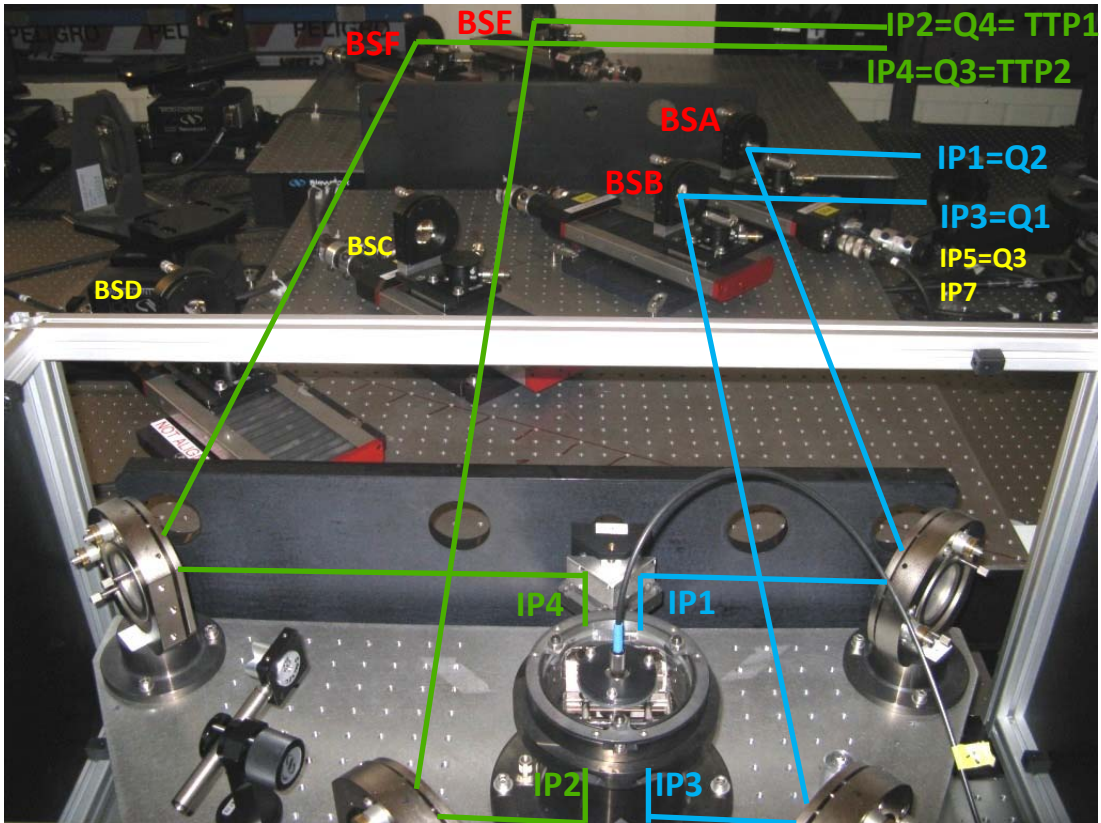

Figure 2: Marcel beam definition

3 M16

Under Wdline call m16gui&

ESO	Cookbook	Doc:	VLT-TRE-ESO-15730-
		Issue:	1
		Date:	21/7/09
		Page:	6 of 35

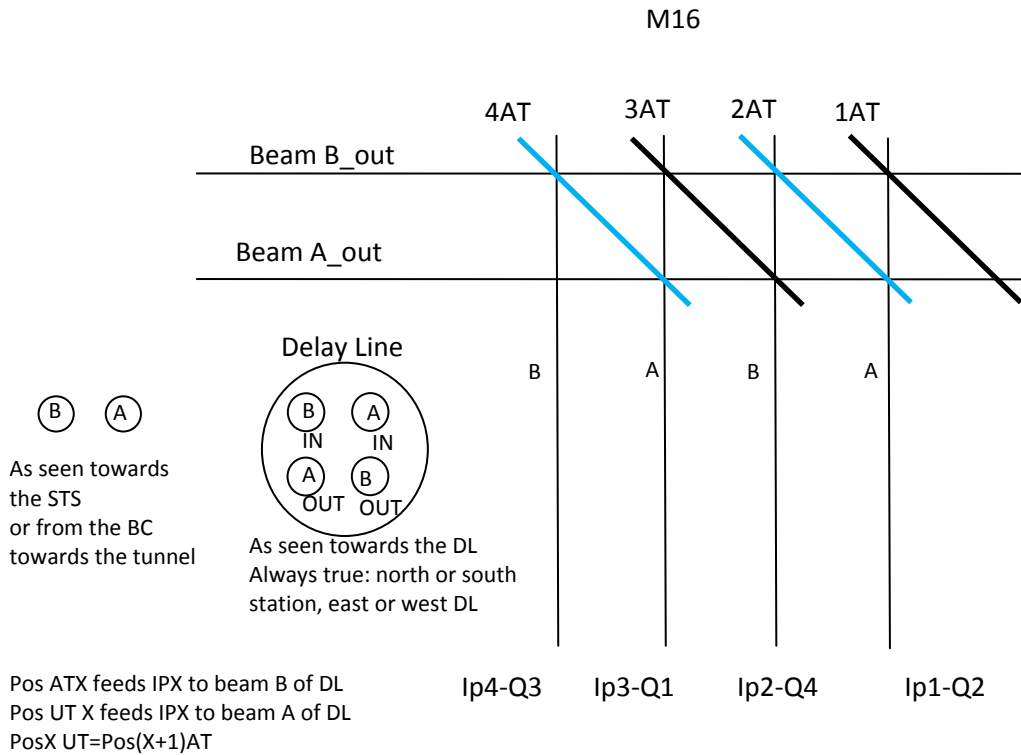

Figure 3: M16 configuration

4 LABORATORY AND ARAL TCCD

waral -l aral
aripanControl &

sometime it is shut down and one as to start again from aropanControl
aropanEngineering &arinsStart

retrieve IRIS centroids on AUTREP
(measured evry day during calibration procedure at ~ 8h00 LT)

```
1/ waral cd /vltdata/tmp/
  grep MARCEL logFile
or grep MARCEL waral.yyyy-mm-dd.ops.log
```

ESO	Cookbook	Doc:	VLT-TRE-ESO-15730-
		Issue:	1
		Date:	21/7/09
		Page:	7 of 35

de 12h UT (8h00 Local) a 12h UT
during COM4 : date of the filename corresponds to date when the measurements were performed

or

2/

go to :

<http://autrep.pl.eso.org/autrep2/pages/autwebLabRep.php>

then copy the following test and chose database connection: GARCHING

```
*****
```

```
# E.S.O. - VLT project
```

```
#
```

```
# who    when    what
```

```
# -----
```

```
# smorel 2009-01-26 created
```

```
*****
```

```
#
```

```
# Script to monitor the position of the MARCEL spots on IRIS
```

```
#
```

```
*****
```

report_body (DataReport)

```
ops_plot (marcel_A.gif)
```

```
  plot_info (MARCEL beam A position, Day,Pixel)
```

```
  plot_number_axis_y (2)
```

```
  plot_mark (3)
```

```
  ops_plot_add (waral,INS IRIS H_XMARCELA, X,0,24)
```

```
  plot_mark (7)
```

```
  ops_plot_add (waral,INS IRIS H_YMARCELA,Y,0,24)
```

```
ops_plot_end
```

```
ops_plot (marcel_B.gif)
```

```
  plot_info (MARCEL beam B position, Day,Pixel)
```

```
  plot_number_axis_y (2)
```

```
  plot_mark (3)
```

```
  ops_plot_add (waral,INS IRIS H_XMARCELB,X,0,24)
```

```
  plot_mark (7)
```

```
  ops_plot_add (waral,INS IRIS H_YMARCELB,Y,0,24)
```

```
ops_plot_end
```

```
ops_plot (marcel_C.gif)
```

```
  plot_info (MARCEL beam C position, Day,Pixel)
```

ESO	Cookbook	Doc:	VLT-TRE-ESO-15730-
		Issue:	1
		Date:	21/7/09
		Page:	8 of 35

```

plot_number_axis_y (2)
plot_mark (3)
ops_plot_add (waral,INS IRIS H_XMARCELC,Beam C X,0,24)
plot_mark (7)
ops_plot_add (waral,INS IRIS H_YMARCELC,Beam C Y,0,24)
ops_plot_end

```

```

ops_plot (marcel_E.gif)
plot_info (MARCEL beam E position, Day,Pixel)
plot_number_axis_y (2)
plot_mark (3)
ops_plot_add (waral,INS IRIS H_XMARCELE,Beam E X,0,24)
plot_mark (7)
ops_plot_add (waral,INS IRIS H_YMARCELE,Beam E Y,0,24)
ops_plot_end

```

```

ops_plot (marcel_F.gif)
plot_info (MARCEL beam F position, Day,Pixel)
plot_number_axis_y (2)
plot_mark (3)
ops_plot_add (waral,INS IRIS H_XMARCELF,Beam F X,0,24)
plot_mark (7)
ops_plot_add (waral,INS IRIS H_YMARCELF,Beam F Y,0,24)
ops_plot_end

```

```
report_end
```

5 DL

```

wldline -l dl
dlpsrvgui &
dlguiStatus
vcmgui &
vcmwsgui & : allow to read Pin Pout and to define POutOffset
              Pin and Pout includes the mechanical position of the DL !

```

```

msgSend wldline dlmswControl GETDELD "dl4"
msgSend wldline dlmswControl SETDELD
"dl4,UT4,U4,112.000000,8.000000,13.044000,209.950000,3,31.8,15.045000,DEFAULT"

```

ESO	Cookbook	Doc:	VLT-TRE-ESO-15730-
		Issue:	1
		Date:	21/7/09
		Page:	9 of 35

dltestTrack <IdlNumber> <startOPL> <speed in mm/s>
dltestPresetDL_VCM <dl> <opl> [<pupil offset of Pupil Out>]

How to make the DL vcm track on its Pin Pout while the DL is moved

make sure that DI are set

msgSend wdlne dlmswControl SETDEL "dIXX"

(otherwise go the ISS but make sure that DLWS is not ignored !)

on dlguiStatus



check that all needed components are ONLINE

- vcms Online Tracking
- VCMX online Tracking
- other ignored

Define parameters of the delay line

Under wdlne

get the current configuration of the DL

msgSend wdlne dlmswControl GETDELD "dlI4"

this returns

DLID, TEL ID, STATION ID,STATION POS U, STATION POS V,STATION POS W,
OPL0,InputChannel,PupilIN,PupilOUT,OPDfilename

ESO	Cookbook	Doc:	VLT-TRE-ESO-15730-
		Issue:	1
		Date:	21/7/09
		Page:	10 of 35

set the current configuration of the DL

`msgSend wdline dlmswControl SETDELD dlmswControl "....."`

note: OPL0 is not important

PupilIn,PupilOut corresponds actually to a PupIn0 and PupOut0 !!! (see ISS doc)

under vcmwsgui

select setup and then preset

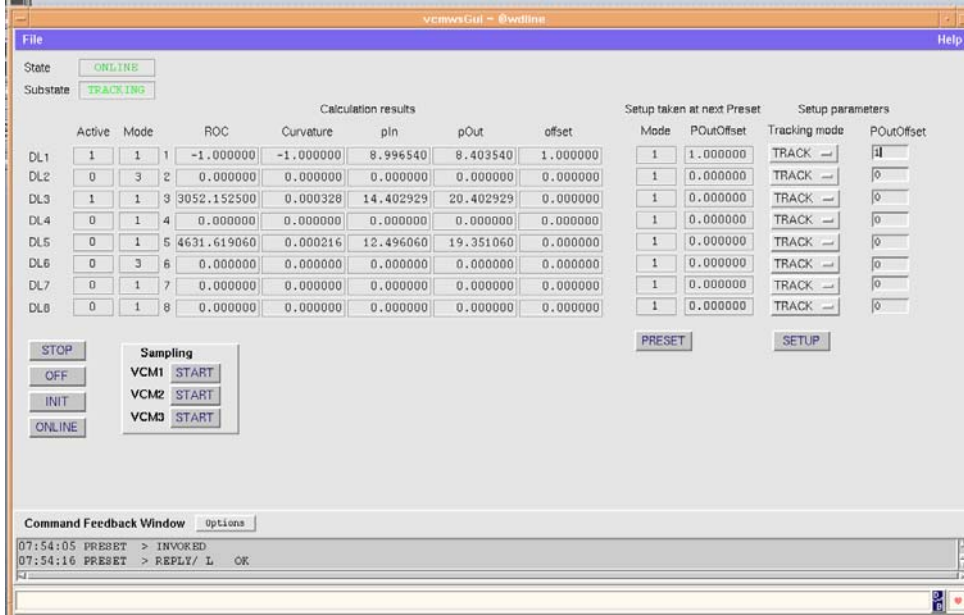

vcmwsgui Pin and Pout includes the position of the DL !!!!!

POutOffset is defined before the BC

for an Offset X after the BC, POutOffset must be set to $X \cdot (4.44)^2 \sim 20 \cdot X$

Matlab code [ComputeVCMParametersATBC](#) requests offset after the BC (=X)

then move the DL using

dltestTrack Idlnumber startOPL speed in mm/s

(Check that PoutOffset is taken into account)

How to change Rate/Acceleration Limiter for individual DL

On wdline->ccseiDb & environmnet Idlx--> select path :delay_line:dlpctl:control:miscdev:fps

6 DDL AND DOPDC

Wddl -l ddl

ddlgui -e IdlX (X=1,2,3,4)

ddlguiStatus

ESO	Cookbook	Doc:	VLT-TRE-ESO-15730-
		Issue:	1
		Date:	21/7/09
		Page:	11 of 35

ddlguiUser

range -34000 microns to 34000 microns

```
cd /vltdata/ENVIRONMENTS/lddIXs
cd ddIDATA
```

STRTREP records max 200000 points at 8kHz (25 sec)
File: tacreport.XXXXXXXXXX.txt

Index time in microsec sampling metrology offsetrmn

To see trajectory plot:
ddIPlotStart X (X=1 2 3 4)

How to change the rate/acceleration limiter:
export TACENV=lddIX
ddltagui &
set the modblk Name to ReferenceRLim?
Param Field: rate=1000 and Acceleration=8000
and select again MODBLCK

7 FSU

1 PSF in K (FWHM)=145 microrad_lab=30 arcsec_lab=0.5 arcmin_lab=0.3 arcsec_sky (AT)
(fiber 9 microns and FSU doublets have $f=62.0543\text{mm}$ at $\lambda=2.3$ microns)

```
psg
wprima
```

check that IRACE server is running
psg iracq
check that there is a iracqServer -inst FSU or FSUB

if it exists,
(advance user: use the alias iracqGUIA (recreate a panel but not a server) to start irace panel)

if it does not exist
iracqFSUA (or B): starts the server and the irace panel at the same time

```
pfdetguia
pfdetguib
      online
(pfdet needs to be online before to use pfcs)
```

ESO	Cookbook	Doc:	VLT-TRE-ESO-15730-
		Issue:	1
		Date:	21/7/09
		Page:	12 of 35

pfcsguib
 pfcsguia
 go online
 enter the parameters
 Ro int=0.001
 GD Rate=1
 RO Mode: NDRO
 ND Sample=14 (set by look upable)
 DUROF=1
 NRESET=2
 and select SET
 (prerequisite: pfcs, pfdet must be online and the irace server running)

pfacugua
 pfacuguib

pfttpgua
 pfttpguib

if detector doe not seem to work, try killing the irace server process
 psg
 kill (number of first column)

to get the flux on rtdscope, one has to use the rmn monitor

rlogin wvgvlti -l mon
 rtdscopGui &
 select the right block (only in stand-by) and go online
 (the metrology need to be online,at least one pmacqgui to work !)

If RTDscope does not display any data:
 check that tacgui is online with the proper config file
 rlogin wvgvlti -l mon (Password: Bnice2me)
 tacgui -e lvgmon
 Init

ESO	Cookbook	Doc:	VLT-TRE-ESO-15730-
		Issue:	1
		Date:	21/7/09
		Page:	13 of 35

select entry box close to config select rmmon.tac
do config
and then go online

check if the rtdscope process died:

-> psg rtd

if the rtdscope process is not listed, need to restart some irace tasks by typing:

->rtdscop -e lvgmon -n rtdscop_lvgmon &

to do spiral search and do BTK need to select

OPMODE in AUTOTEST

for pfttgui and pfacugui

(different from sky positions)

⇒ start from

offpos: start from current position and go away by 200 micro rad

center: go to zero ; zero

wvgvlti mon:~ 178 > tacgui &

check that tacgui &-> init online to get "default config" defined to rmmon.tac

wvgvlti mon:~ 179 > rtdscopegui & --> use flux !

8 PACMAN

rlogin wpacman -l pacman

bob &

load PACMAN_gen_Record

DIT how long do we record

NDIT how many times the template is looped

RECMODE=PACMAN

TARGET=SAMUEL (this will appear in the keyword OBS_TAG_NAME)

cd /rmnrec

ls -ltr

PACMAN_GEN_RECORD* should appear

to see data:

rtd PACMAN_GEN_RECORD*

ESO	Cookbook	Doc:	VLT-TRE-ESO-15730-
		Issue:	1
		Date:	21/7/09
		Page:	14 of 35

testing at Paranal

to run the FSU template from PACMAN, ISS needs to be configured properly
 issguiObsStatus should be in state ONLINE
 if not
 need to ignore for example DLCS ARAL (if they were not online)

FeedMode should be SINGLE_FSUA

to select this, start issguiConfig on the machine wvgvlti user iss
 under EDIT MODE (top), select expert mode
 then select feedMode

also the configuration must be valid...
 if not change valid config on issguiConfig

to run templates which do not require ISS to be configured (OBSOLETE)

use template not from PACMAN but from the rmn recorder machine

```
wvgreg -l rec
bob
select the proper template
data are located in $INS_ROOT/SYSTEM/DETDATA
```

9 RMNMON

How to use rmnmon

```
wvgvlti -l mon
```

```
rmassopgui &
```

choose none

```
RTD_scope
```

choose block

Recording-> filename saved where rmassopgui & was started

10 IRIS

```
waral
irisguiEngineering
```

ESO	Cookbook	Doc:	VLT-TRE-ESO-15730-
		Issue:	1
		Date:	21/7/09
		Page:	15 of 35

irisrtd

If IRIS RTD is running somewhere else, you may have to kill the process

do : psg iris

and kill the process (first column number)

if it is defunct...try kill -9 <process number>

sometimes need to kill "seqwish .rtdb.." process and not the rtd...

irisguiEngineering

startX=1 (only odd !0

starty=1

winsize=128 (only even !)

Uncorr

fenetre 32 centree sur 64x64

using Marcel: IRIS: window 47,47 size 32, double corr such that small min dit can be used (otherwise IRIS saturates)

```
msgSend "" iriswsControl SETIRIS "Q,TEL,STATION"
```

```
msgSend "" iriswsControl SETREFB "Q,X,Y" (set ref pixel for a given Q)
```

```
msgSend "" iriswsControl CLRIRIS
```

IRIS ref pixel not properly set by ISS in dial feed config (use 64,64) instead of (64,52): Fixed by Philippe by updating iriszeropointtable (under irisdata ccseIDb)

How to take IRIS movies

```
./irisMovieShutBGD.sh time_in_sec filename
```

first do background by moving Notch translation stage with black paper on it

Then takes movies

nb of frame depends on actual DIT and selected time in sec

ESO	Cookbook	Doc:	VLT-TRE-ESO-15730-
		Issue:	1
		Date:	21/7/09
		Page:	16 of 35

from vltuser/ara/GIP
do more irisMovieShutBGD.sh for manual
data are collected in \$INS_ROOT/SYSTEM/DETDATA

(path normally always used to save image data)

middle button CCD Guider FAS
or guide acquisition: can also save image from there
(or RTD guider FAS)
data should be saved in \$INS_ROOT/SYSTEM/DETDATA

Configuration	IRIS Filter	IFOA	IFO
Daily calibration	H	dichroics	mirror
FINITO/AMBER	K	dichroics	Mirror
PRIMA	H	mirrors	dichroics

11 AT-STs

on the terminals of the VLTI control room

- log as user=at1, 2, 3 or 4 pwd=Bnice2me

```
watXtcs -l atcs
Bnice2me
```

```
Export LCUENV =latXvcm
vcmgui &
```

```
pspzgui -l latXvcm
pspzgui -l latXfsm
```

```
export LCCENV=lat4fsm
mvdrotgui &
```

ESO	Cookbook	Doc:	VLT-TRE-ESO-15730-
		Issue:	1
		Date:	21/7/09
		Page:	17 of 35

TCCD of the AT's:
 rtd –camera ccdagfas &

to get the AT during day-time ready for test, with shutter open:

- ➔ run osfScript: atosfDayTimeTests.osf
- ➔ this script is equivalent to day-to-night, but it preserves the cooling. \; may have start air-conditioning manually

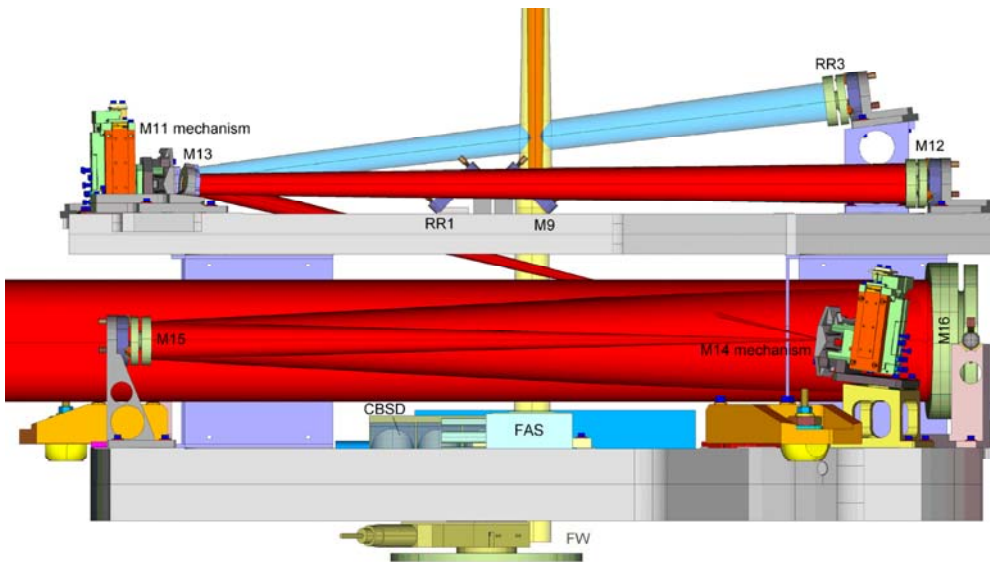
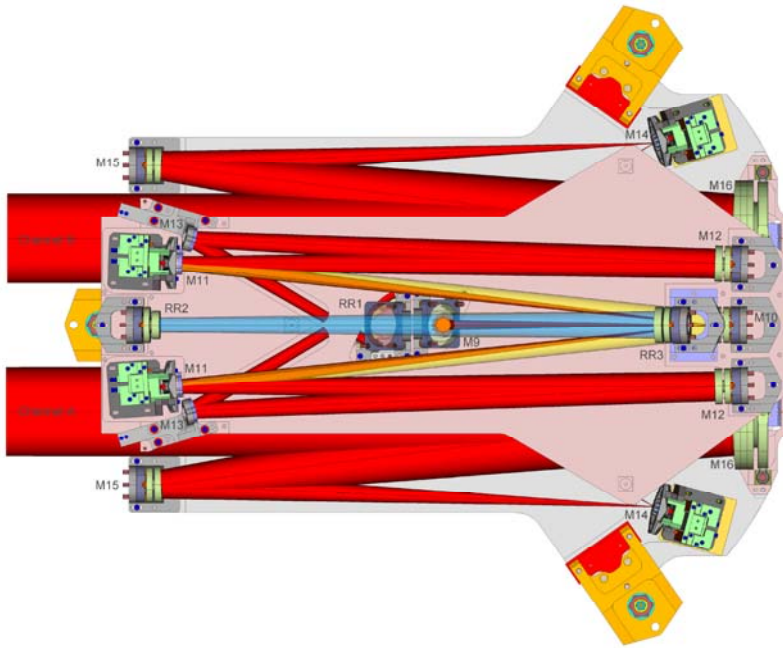

ESO	Cookbook	Doc:	VLT-TRE-ESO-15730-
		Issue:	1
		Date:	21/7/09
		Page:	18 of 35

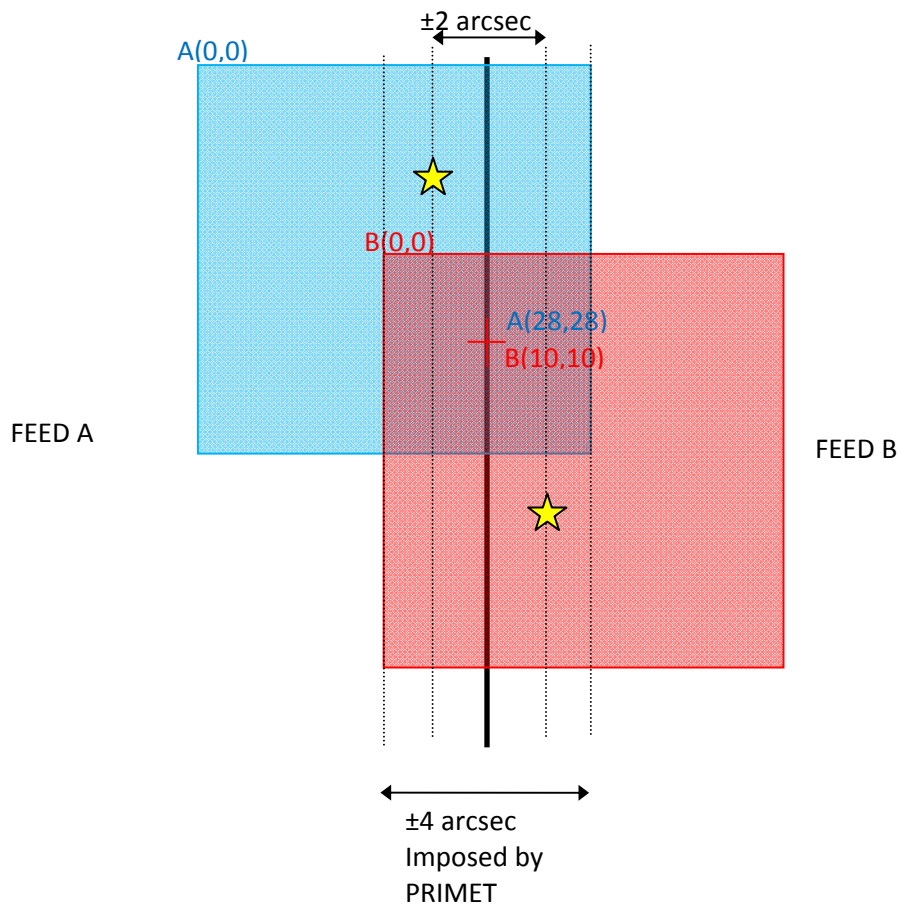

STS-M10 and fsm positions

Scale TCCD: 6 pixels/arcsec_{sky}.

AT3-ST3: The difference between Az axis and M10 edge is 2.4 pixels along X or 0.4 arcsec_{sky}

ESO	Cookbook	Doc:	VLT-TRE-ESO-15730-
		Issue:	1
		Date:	21/7/09
		Page:	19 of 35

From Com7:

Scale FSM $\sim 0.45 \text{ microns_piezo/arcsec_sky}$ or $2.2 \text{ arcsec_sky/micron_piezo}$
 $0.075 \text{ microns_piezo/pixel}$ or $13.3 \text{ pix/micron_piezo}$

The scale factor $\text{fsm}(\text{micron_piezo})$ to $\text{fsm}(U,W)$ is about 50

12 PRIMA RECORDER ETC..



13 ISS

telnet wvgvlti (rlogin does not work)

user: iss

PWD:

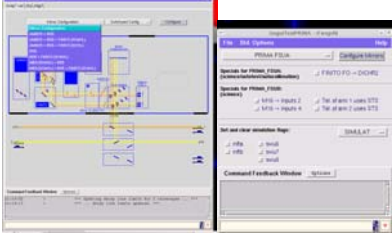
PARANAL OPERATIONAL VERSION OF ISS

<p>issguiConfig : Configure down to the SW</p> 	<p>issguiObsMain: does not allow to configure the lab for pacman. Need to use issguiTestPRIMA &:</p> 	<p>issguiObsStatus</p> 
---	---	--

VERSION OF ISS for COM10

<p>issguiConfig : Configure down to the SW</p>	<p>issguiObsMain2: allow to configure the lab for pacman.</p>	<p>issguiObsStatus2 new tab with "beams"</p>
---	--	---

<h1>ESO</h1>	<h2>Cookbook</h2>	Doc:	VLT-TRE-ESO-15730-
		Issue:	1
		Date:	21/7/09
		Page:	20 of 35



issguiConfTest example

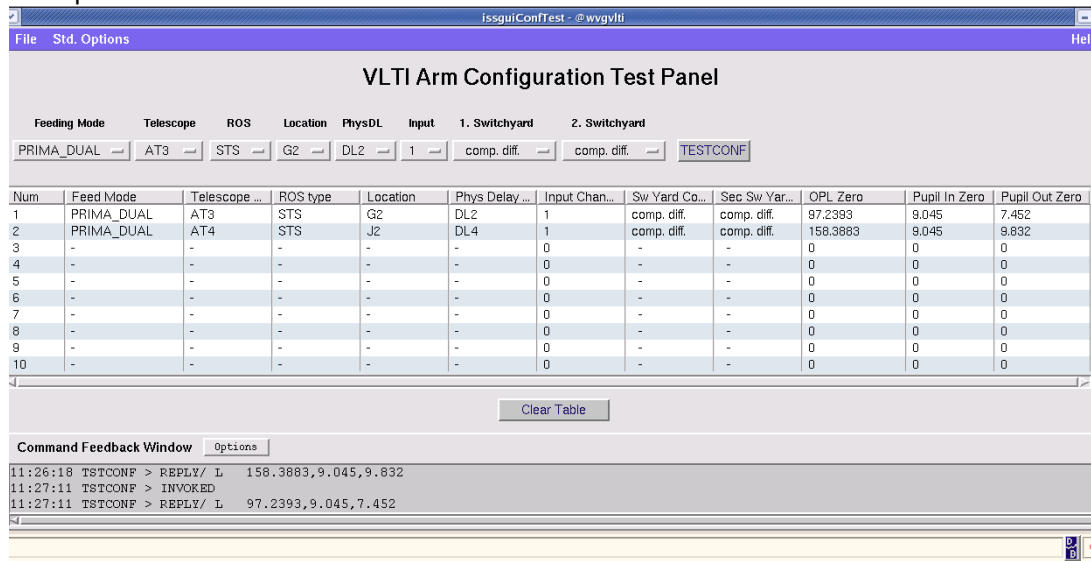

Config Com14 with Pupil offsets for AT4-J2

ESO	Cookbook	Doc:	VLT-TRE-ESO-15730-
		Issue:	1
		Date:	21/7/09
		Page:	21 of 35

File Std. Options Help

VLT Arm Configuration Test Panel

Feeding Mode Telescope ROS Location PhysDL Input 1. Switchyard 2. Switchyard

PRIMA_DUAL AT3 STS G2 DL2 1 comp. diff. comp. diff. TESTCONF

Num	Feed Mode	Telescope ...	ROS type	Location	Phys Delay ...	Input Chan...	Sw Yard Co...	Sec Sw Yar...	OPL Zero	Pupil In Zero	Pupil Out Zero
1	PRIMA_DUAL	AT3	STS	G2	DL2	1	comp. diff.	comp. diff.	97.2393	9.007	7.452
2	PRIMA_DUAL	AT4	STS	J2	DL4	3	comp. diff.	comp. diff.	158.1483	74.066	15.045
3	-	-	-	-	-	0	-	-	0	0	0
4	-	-	-	-	-	0	-	-	0	0	0
5	-	-	-	-	-	0	-	-	0	0	0
6	-	-	-	-	-	0	-	-	0	0	0
7	-	-	-	-	-	0	-	-	0	0	0
8	-	-	-	-	-	0	-	-	0	0	0
9	-	-	-	-	-	0	-	-	0	0	0
10	-	-	-	-	-	0	-	-	0	0	0

Clear Table

Command Feedback Window Options

```

10:40:21 TSTCONF > REPLY/ L 158.1483,74.066,15.045
10:40:33 TSTCONF > INVOKED
10:40:33 TSTCONF > REPLY/ L 97.2393,9.007,7.452

```

Test Configuration Table

1 PRIMA_DUAL AT4 STS J2 DL4 Ip3 comp. diff. comp. diff.

OPLZero=158.1483

Pupil In Zero=22.796

Pupil Out Zero=15.045

2 PRIMA_DUAL AT3 STS A1 DL6 Ip1 comp. diff. comp. diff.

OPLZero=173.0293

Pupil In Zero=81.777

Pupil Out Zero=10.952

Baseline: B(J2-A1)=124.2 m

ESO	Cookbook	Doc:	VLT-TRE-ESO-15730-
		Issue:	1
		Date:	21/7/09
		Page:	22 of 35

14 VCM CURVATURES FOR THE AT AND DL

14.1 AT#4-J2 DL#4(-ip3)

Theoretical STS-VCM curvature:

Using STS_VCM_Samuel.m

<pre> Station J2 Delay Line DL#4 STS DATA FDE ***** VCM_STS ***** V-Offset to station center OFS 3.987000e-001 (m) STS VCM ROC is: -0.2210735 (m) STS VCM curvature is: -4.523382e-003 (mm-1) Pout is: 9.089870e+001 (m) </pre>	<pre> Station J2 Delay Line DL#4 STS DATA VLT-SPE-ESO-15736-3186 issue 2.8 april 2007 ***** VCM_STS ***** V-Offset to station center OFS 3.987000e-001 (m) STS VCM ROC is: -0.2098233 (m) STS VCM curvature is: -4.765915e-003 (mm-1) Pout is: 9.089870e+001 (m) </pre>
---	--

ESO	Cookbook	Doc:	VLT-TRE-ESO-15730-
		Issue:	1
		Date:	21/7/09
		Page:	23 of 35

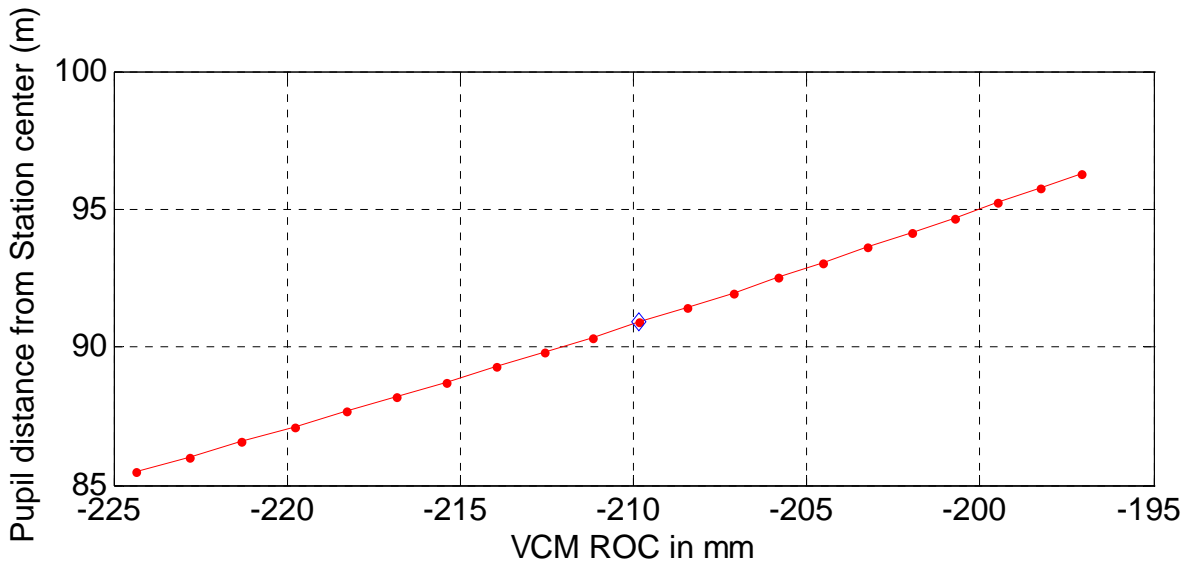
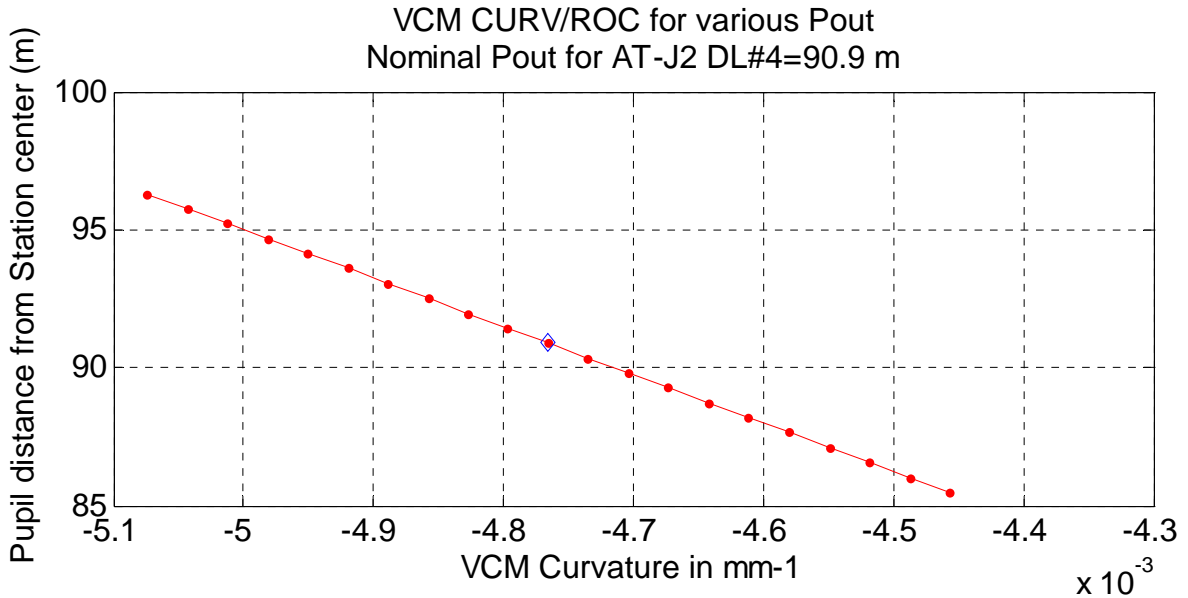

$$P_{out}(m) = -17542 \times VCM_CURV(mm^{-1}) + 7.296$$

$$\Delta P_{out} / \Delta C = -17542 m / (mm^{-1})$$

$$P_{out}(m) = -0.3968 \times VCM_ROC(mm) + 174.29$$

$$\Delta P_{out} / \Delta ROC = -0.3968 m / (mm)$$

ESO	Cookbook	Doc:	VLT-TRE-ESO-15730-
		Issue:	1
		Date:	21/7/09
		Page:	24 of 35

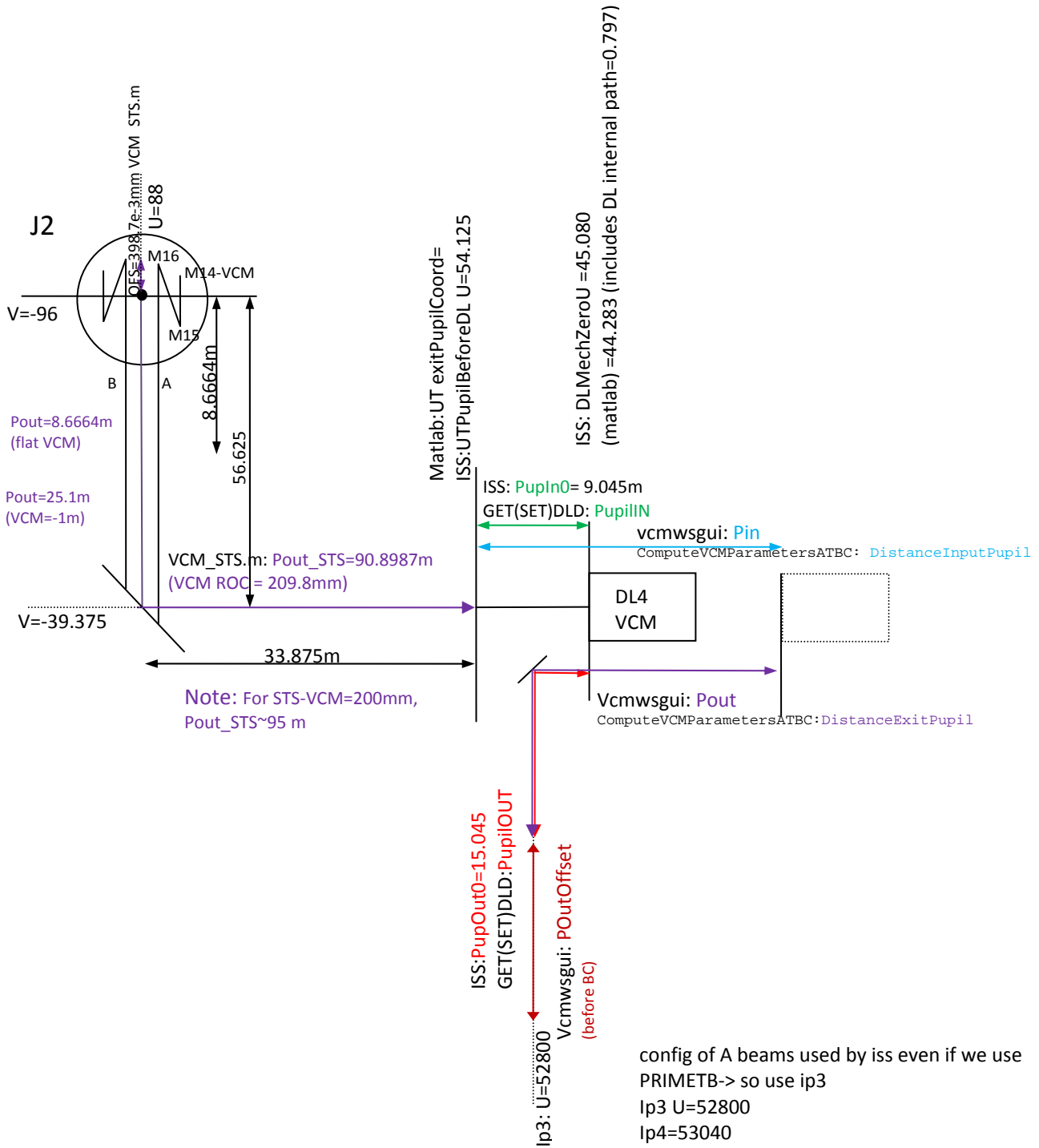

ESO	Cookbook	Doc:	VLT-TRE-ESO-15730-
		Issue:	1
		Date:	21/7/09
		Page:	25 of 35

For Nominal VCM ROC=-210mm

What is the DL4-VCM ROC for DL4_OPL=14m=2x7m

ComputeVCMParametersATBC('UT4',4,3,7,4.5,-1)

Telescope = UT, Station = UT4, DL 4 @ Position 7. m, Lab Input Channel #3, Pupil offset after BCs 4.5 m, VCM radius adjusted

- Input pupil distance `DistanceInputPupil` (for DLpos=7) = 16.842m= ISS `PupIn0`(9.0450)+DL internal path(0.797)+7m
- Exit pupil distance required `DistanceExitPupil` (for DLpos=0)=111.71m= ISS `PupOut0` (15.045)+DL internal path(0.797)+7m+ shift 4.5m*4.44²
- VCM ROC required (with specific DL optical par.) = 2.506195e+002 mm
- VCM curv required (with specific DL optical par.) = 3.990112e-003 mm-1

For Flat STS-VCM's,

ISS:UTPupilBeforeDL must be redefined defined from **U=54.125** to

U=54.125 +[33.875+56.625-8.664]= 54.125 +81.836= **135.961**

For STS-VCM ROC=-1m (installed in Paranal)

Pout=(`distATPupFixVCM`)=25.5

PupIn0(ISS) must be redefined to [9.045+33.875+56.625-25.5]=74.045m

Or use: UTPupilBeforeDL U=**54.125**+33.875+56.625-25.5=119.125

ComputeVCMParametersATBC('UT4',4,3,7,4.5,-1)

Telescope = UT, Station = UT4, DL 4 @ Position 7. m, Lab Input Channel #3, Pupil offset after BCs 4.5 m, VCM radius adjusted

- Input pupil distance `DistanceInputPupil` (for DLpos=7) = 81.84= ISS `PupIn0`(74.045m)+DL internal path(0.797)+7m
- Exit pupil distance required `DistanceExitPupil` (for DLpos=0)=111.71m= ISS `PupOut0` (15.045)+DL internal path(0.797)+7m+ shift 4.5m*4.44²
- VCM ROC required (with specific DL optical par.) = 1.540952e+002 mm
- VCM curv required (with specific DL optical par.) = 6.489496e-003 mm-1

Observation from COM12

- PupIn0(ISS) must be set in practice to 31.8m to get the proper metrology beam shape (and get DL4-VCM=0.56 bar for DL4_OPL=14m)
- Therefore the STS-output pupil must be shifted towards the center of the tunnel by 74.045-31.8=42.245m
- This corresponds to redefining `distATPupFixVCM` from 25.5 to 25.5+42.245=**67.745m**
- Or UTPupilBeforeDL U=119.125-42.245=76.88

Observation from COM15 (ACOM1)

- PupIn0(ISS) must be set in practice to 23 m (compared to 31.8 of Com12) to get the proper metrology beam. This represents a shift of 8.8 m towards the center of the tunnel
- This corresponds to redefining `distATPupFixVCM` from **67.745m to 67.745+8.8=76.54m**
- Or UTPupilBeforeDL U=76.88-8.8=68.08

ESO	Cookbook	Doc:	VLT-TRE-ESO-15730-
		Issue:	1
		Date:	21/7/09
		Page:	26 of 35

ComputeVCMParametersATBC('UT4',4,3,7,4.5,-1)

Telescope = UT, Station = UT4, DL 4 @ Position 7. m, Lab Input Channel #3, Pupil offset after BCs 4.5 m, VCM radius adjusted

- Input pupil distance `DistanceInputPupil` (for DLpos=7) = 30.79~ ISS PupIn0(23m)+DL internal path(0.797)+7m
- Exit pupil distance required `DistanceExitPupil` (for DLpos=0)=111.71m= ISS PupOut0 (15.045)+DL internal path(0.797)+7m+ shift 4.5m*4.44^2
- VCM ROC required (with specific DL optical par.) = 2.209110e+002 mm
- VCM curv required (with specific DL optical par.) = 4.526711e-003 mm-1

Theoretical DL-VCM Curvature as a function of the DL4 position (with zero offset)

example:

ComputeVCMParametersATBC('UT4',4,4,0,0,-1)

Telescope = UT, Station = UT4, DL 4 @ Position 0.000000 m, Lab Input Channel #4, Pupil offset after BCs 0.0 m,

- Input pupil distance `DistanceInputPupil` (for DLpos=0) = 9.842m= ISS PupIn0(9.0450)+DL internal path(0.797)
- Exit pupil distance required `DistanceExitPupil` (for DLpos=0) = 16.082m= ISS PupOut0 (15.285) +DL internal path(0.797)
- VCM radius required = out of range (22.8m) instead of max 2.8 m

ComputeVCMParametersATBC('UT4',4,4,7,0,-1)

Telescope = UT, Station = UT4, DL 4 @ Position 7.000000 m, Lab Input Channel #4, Pupil offset after BCs 0.0 m,

- Input pupil distance `DistanceInputPupil` (for DLpos=0) = 16.842m= ISS PupIn0(9.0450)+DL internal path(0.797)+7m
- Exit pupil distance required `DistanceExitPupil` (for DLpos=0)=23.082m= ISS PupOut0 (15.285)+DL internal path(0.797)+7m
- VCM ROC required (with specific DL optical par.) = 1.718024 m
- VCM curv required (with specific DL optical par.) = 5.82064e-004 mm-1

ESO	Cookbook	Doc:	VLT-TRE-ESO-15730-
		Issue:	1
		Date:	21/7/09
		Page:	27 of 35

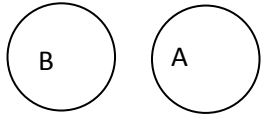

As seen towards the STS
or from the BC towards the
tunnel

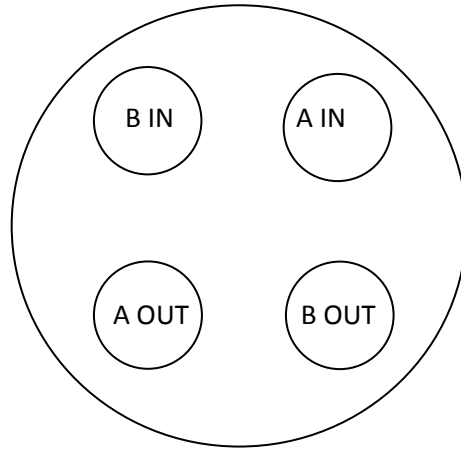

As seen towards the DL
Always true: north or south
station, east or west DL

Test identite des donnees Matlab et VLT SW

Control Model DL1,3,5 uniquement dispo

ComputeVCMParametersATBC('UT1',1,1,0,0,-1)

Telescope = UT, Station = UT1, DL 1 @ Position 0.000000 m, Lab Input Channel #1, Pupil offset after BCs 0.0 m,

```
> Input pupil distance (*)           = 9.092000e+000 m      PupIn0
> Exit pupil distance required       = 7.499000e+000 m      PupOut0
```

ComputeVCMParametersATBC('UT1',1,3,0,0,-1)

Telescope = UT, Station = UT1, DL 1 @ Position 0.000000 m, Lab Input Channel #3, Pupil offset after BCs 0.0 m,

```
Input pupil distance (*)           = 9.092000e+000 m      PupIn0
Exit pupil distance required       = 1.175200e+001 m      PupOut0
```

msgSend wdlne dlmswControl SETDELD dlmswControl "....."
DLID, TEL ID, STATION ID,STATION POS U, STATION POS V,STATION POS W,
OPL0,InputChannel,PupIlIN,PupilOUT,OPDfilename

Put DL#1 at pos=0

Check on the vcmwsgui that Pin and Pout corresponds to

ccseiMsg on the dlmswControl Process

ESO	Cookbook	Doc:	VLT-TRE-ESO-15730-
		Issue:	1
		Date:	21/7/09
		Page:	28 of 35

14.2 AT#3-G2 DL#2

Using STS_VCM_Samuel.m: Determine theoretical ROC for the AT-ST5 VCM for the station G2

<pre> Station G2 Delay Line DL#2 STS DATA FDE ***** VCM_STS ***** V-Offset to station center OFS 3.987000e-001 (m) STS VCM ROC is: -7.446345e-001 (m) STS VCM curvature is: -1.342941e-003 (mm-1) Pout is: 3.214870e+001 (m) </pre>	<pre> Station G2 Delay Line DL#2 STS DATA VLT-SPE-ESO-15736-3186 issue 2.8 april 2007 ***** VCM_STS ***** V-Offset to station center OFS 3.987000e-001 (m) STS VCM ROC is: -7.313170e-001 (m) STS VCM curvature is: -1.367396e-003 (mm-1) Pout is: 3.214870e+001 (m) </pre>
---	---

Effect of Flat VCM on AT3-ST5: The STS reimages the pupil at **Pout=8.6664 m**.

Origin of the result:

1. Use STS_VCM.m and scan "UTOutPupilu" until ROC converges to infinity. Pout~8.99

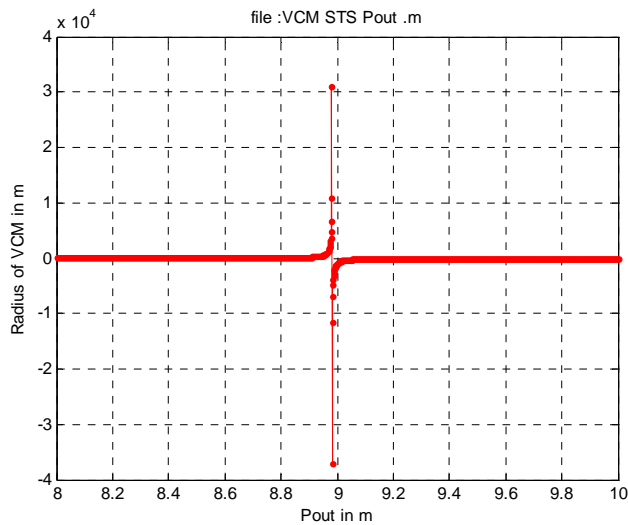

2. check com 2 report where we found that for AT3-G2: $Pout(m) = -17200 \cdot VCM_curv(mm-1) + 8.6664$. For $curv=0$, $Pout=8.6664$

So, with a flat STS-VCM, the DL input pupil position is increased by $32.1487 - 8.6664 = 23.4823m$

$PupIn0$ becomes $[9.045 + 32.1487 - 8.6664] = 32.5273 m$

Equivalent to redefining $UTPupilBeforeDL U = 49.875 - 32.1487 + 8.6664 = 26.3927$

ESO	Cookbook	Doc:	VLT-TRE-ESO-15730-
		Issue:	1
		Date:	21/7/09
		Page:	29 of 35

The corresponding DL-VCM adjustment is given by

ComputeVCMParametersATBC('UT2',2,2,0,0,-1) after redefining UTPupilBeforeDL for UT2=26.3927 in the code

- Input pupil distance `DistanceInputPupil` (for DLpos=0) = 33.32430 m = `PupIn0(32.5273)+DL internal path(0.797)`
- Exit pupil distance required `DistanceExitPupil` (for DLpos=0) = 8.009000 m
- VCM radius required = 1.558980 m

Exit pupil `Pout`=8.009 including the DL internal path (0.797m)

So we should have ISS:`PupOut0=GET(SET)DLD:PupilOUT=8.009-0.797=7.212 m`

config of A beams used by iss even if we use PRIMETB-> so use ip3

ip3 U=52800

ip4=53040

ESO	Cookbook	Doc:	VLT-TRE-ESO-15730-
		Issue:	1
		Date:	21/7/09
		Page:	30 of 35

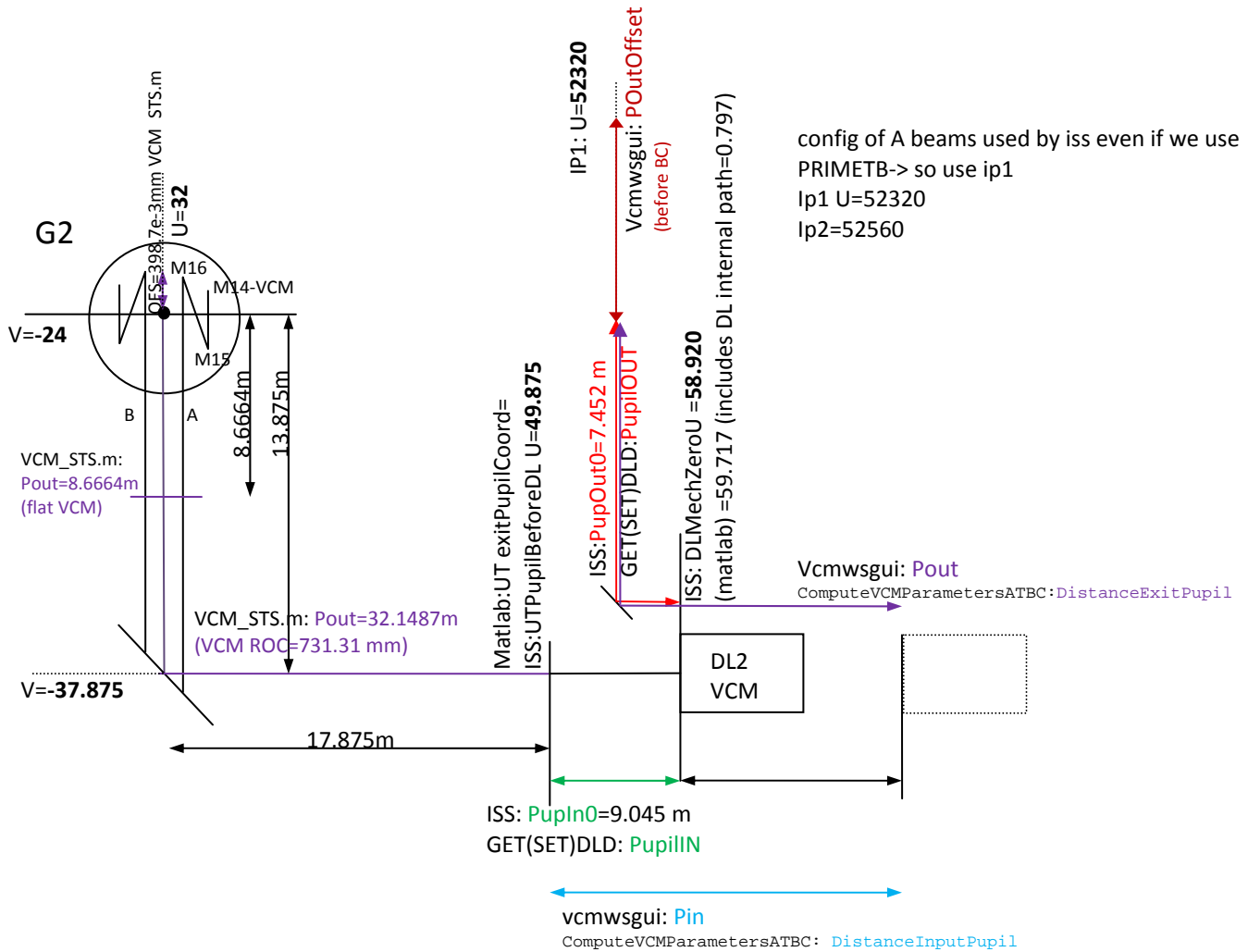

For Nominal VCM ROC=-731mm

ISS:UTPupilBeforeDL=49.875m

What is the DL4-VCM ROC for DL4_OPL=14m=2x7m ?

ComputeVCMParametersATBC('UT2',2,1,7,4.5,-1)

Telescope = UT, Station = UT2, DL 2 @ Position 7.000000 m, Lab Input Channel #1, Pupil offset after BCs 4.5 m, VCM radius adjusted

- Input pupil distance (*) = 1.684200e+001 m
- Exit pupil distance required = 1.041201e+002 m
- VCM ROC required (with specific DL optical par.) = 2.701721e+002 mm

ESO	Cookbook	Doc:	VLT-TRE-ESO-15730-
		Issue:	1
		Date:	21/7/09
		Page:	31 of 35

- VCM curv required (with specific DL optical par.) = 3.701344e-003 mm-1

For Flat STS-VCM's,

ISS:UTPupilBeforeDL must be redefined defined from U=**49.875** to
U=49.875 -[17.875+13.875-8.6664]= 49.875 -23.0836=**26.791**

Note: for Roc=-2000mm, Pout=17.5 m this represents a shift of $\Delta P_{out}=17.5-8.6664=8.8336$ m compared to the flat VCM case.

14.3 Summary DI-VCM ROC for OPL=14m obtained after ACOM1

DL VCM Curvature for DI at OPL=14m (mechanical distance=7m)

AT3-G2 with STS-VCM_ROC=-731mm (nominal case, like UT case)
(distATPupFixVCM = **31.79m**; ; **Pin0/DL4=9.045m**; **UTPupilBeforeDL=49.875m**)
ComputeVCMParametersATBC('UT2',2,1,7,4.5,-1)

- DL2-VCM ROC required = 2.701721e+002 mm
- DL2-VCM curv required = 3.701344e-003 mm-1

AT4-J2 with STS-VCM_ROC=-1000mm (NOT nominal case, but currently installed VCM)
(distATPupFixVCM = **25.5m**; **Pin0/DL4=74.045m**; **UTPupilBeforeDL= 119.125 m**;)
ComputeVCMParametersATBC('UT4',4,3,7,4.5,-1)
Theoretical values:

- DL4-VCM ROC required = 1.540952e+002 mm
- DL4-VCM curv required = 6.489496e-003 mm-1

Values based on the calibration of the PRIMET beam shape during ACOM1 (July2011)
(i.e. Based on distATPupFixVCM = **76.54m** ; **Pin0/DL4=23m**; **UTPupilBeforeDL= 68.08 m**)
ComputeVCMParametersATBC('UT4',4,3,7,4.5,-1)

- DL4-VCM ROC required = 2.209110e+002 mm
- DL4-VCM curv required = 4.526711e-003 mm-1

ESO	Cookbook	Doc:	VL-TRE-ESO-15730-
		Issue:	1
		Date:	21/7/09
		Page:	32 of 35

14.4 AT#3-A1-DL6-(Ip1)

(sketched to be flipped w.r.t vertical axis)

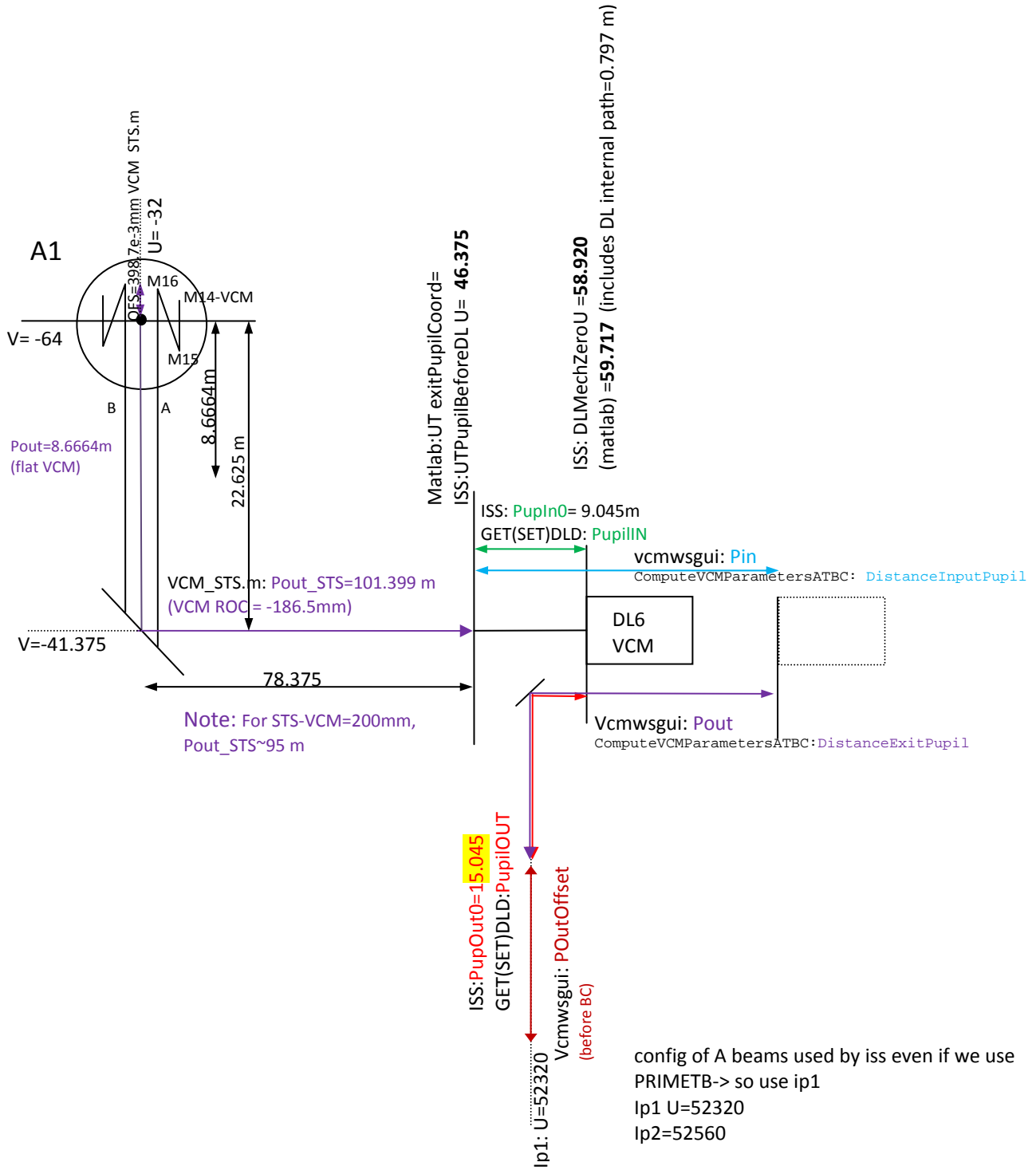

ESO	Cookbook	Doc:	VLT-TRE-ESO-15730-
		Issue:	1
		Date:	21/7/09
		Page:	33 of 35

15 FIELD ORIENTATION ON THE AT-TCCD

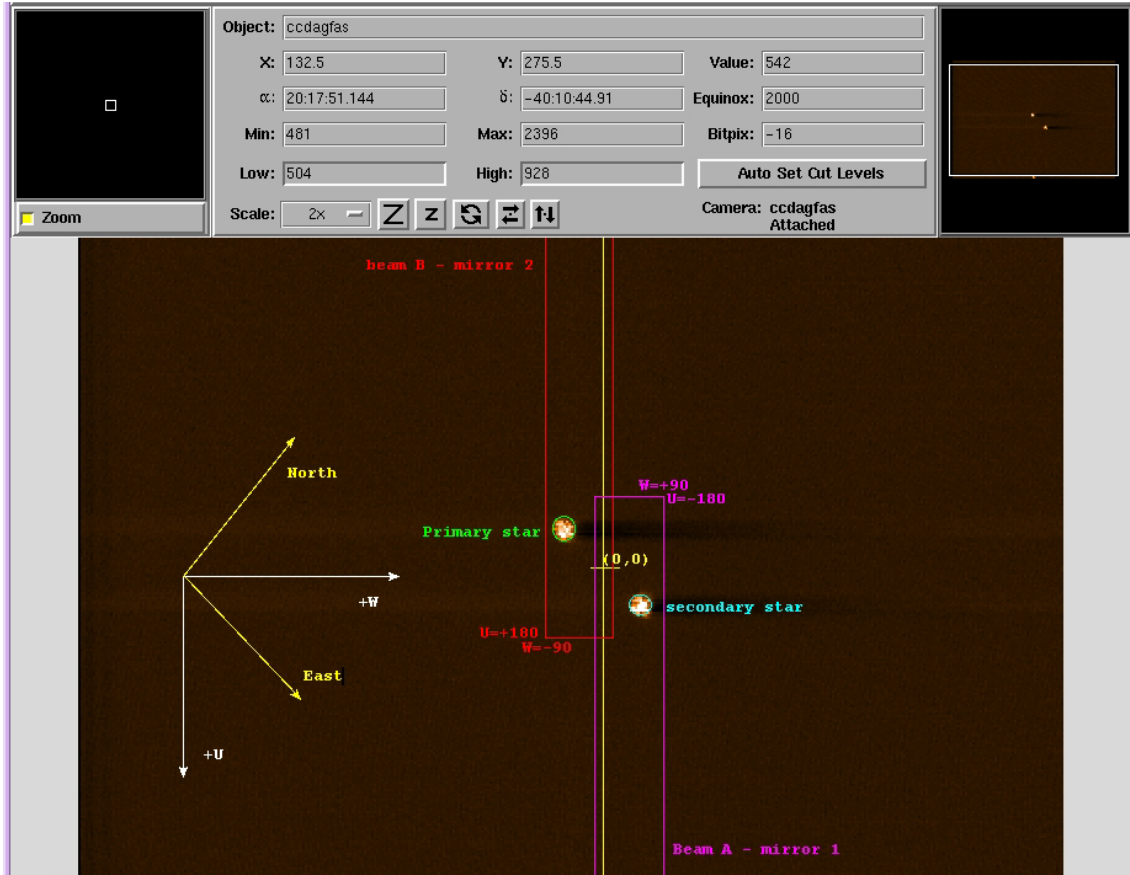

Figure 4: For example only: AT#3-ST5 (G2) during AIV

16 UNIX POUR LES NULS AND USEFUL COMMANDS

sftp:

- how to use local commands: add !

example:

```
lls
```

to recall last command: use !

example !sftp

will call the last sftp command, useful to connect to odyssey3....

when being the sftp session , you can delete a character by typing CtrlH

```
lftp sftp://vltitec@odyssey3
```

ESO	Cookbook	Doc:	VLT-TRE-ESO-15730-
		Issue:	1
		Date:	21/7/09
		Page:	34 of 35

To access easily odyssey3 and the PRIMA logs

- ssh -XY vltitec@odyssey3.pl.eso.org
- <https://websqa.hq.eso.org/sdd/bin/viewauth/PRICS/>

How make a screen shot

gnome-panel-screenshot --delay 10

fichier saved in: /vltuser/ara1/filename.pgn

(if you use ARAL)

or

kssnapshot

lftp sftp://vltitec@odyssey3

msgSend wdlne dlmswControl GETDELD "dl4"

msgSend wdlne dlmswControl SETDELD

"dl4,UT4,U4,112.000000,8.000000,13.044000,209.950000,3,31.8,15.045000,DEFAULT"

msgSend "" iriswsControl SETIRIS "Q,TEL,STATION"

msgSend "" iriswsControl SETREFB "Q,X,Y"

msgSend "" iriswsControl CLRIRIS

dltestTrack <dlNumber> <startOPL> <speed in mm/s>

dltestPresetDL_VCM <dl> <opl> [<pupil offset of Pupil Out>]

<http://autrep.pl.eso.org/autrep2/pages/>

ccseIDb

-> environment wvgvlti

DB Path

Appl_data->VLT1->VLTParameters->optics->distATPupFixVCM

Table

dbDouble value

0(=AT1) 8.6 (flat vcm)

1(=AT2) 8.6 (flat vcm)

2(=AT3) 31.79 (vcm_AT-ST5=-0.731m)

3(=AT4) 25.5 (vcm_AT-ST5=-1m) to be changed to 67.77 (value calibrated during COM12)

ESO	Cookbook	Doc:	VLT-TRE-ESO-15730-
		Issue:	1
		Date:	21/7/09
		Page:	35 of 35

Need to configure iss afterwards
issguiConfig--> Configure

dltestPresetDL_VCM <dl> <opl> [<pupil offset>] ->= offset of pupil out !

__oOo__