



EUROPEAN SOUTHERN OBSERVATORY

Organisation Européenne pour des Recherches Astronomiques dans l'Hémisphère Austral
Europäische Organisation für astronomische Forschung in der südlichen Hemisphäre

ESO - European Southern Observatory
Karl-Schwarzschild Str. 2, D-85748 Garching bei München

Very Large Telescope Paranal Science Operations GRAVITY User Manual

Doc. No. ESO-283854

Issue 114.0, Date 2024-02-13

Prepared Gravity IOT 2024-02-13
Date Signature

Approved S. Mieske
Date Signature

Released A. Kaufer
Date Signature

This page was intentionally left blank

Change Record

| Issue/Rev. | Date | Sect. / Paragr. affected | Remarks |
|------------|------------|-----------------------------|---|
| 098.0 | 2016-08-19 | | first version adapted from the one delivered by the consortium |
| 099.0 | 2016-09-11 | various | new modes for P99 (UTs, low resolution) |
| 100.0 | 2017-03-01 | various | LP, good weather, SF low-res |
| 101.0 | 2017-09-01 | various | minor revisions throughout the text |
| 102.0 | 2018-02-28 | various | updates throughout the text |
| 103.0 | 2018-08-30 | 5.1.3 & 5.2.3 | time justification; added “on-axis” dual-field |
| 104.0 | 2019-02-15 | various | limiting magnitudes; CIAO on-axis; DF separations |
| 104.0 | 2019-08-28 | 1.2, 2.7 & 5 | instrument performance, new P1 tool, calibrators |
| 106.0 | 2020-05-26 | various | revisions throughout the text & figures updated |
| 110.0 | 2022-02-24 | various | adding information on dual-field wide and small revisions throughout the text |
| 112.0 | 2023-02-24 | various | new acquisition templates |
| 112.1 | 2023-06-28 | various | small revisions throughout the text |
| 114.0 | 2024-02-13 | all | New information on GPAO and GRAVITY Wide |

This page was intentionally left blank

Contents

| | | |
|----------|---|-----------|
| 1 | Introduction | 1 |
| 1.1 | Scope | 1 |
| 1.2 | Current state and recent changes | 1 |
| 1.3 | Contents of the manual | 2 |
| 1.4 | Contact Information | 2 |
| 2 | Context | 2 |
| 2.1 | Is GRAVITY the right instrument for your science programme? | 3 |
| 2.2 | GRAVITY and other ESO instruments | 3 |
| 2.3 | Optical interferometry basics | 3 |
| 2.4 | GRAVITY observables | 5 |
| 2.4.1 | Absolute visibility $V(\mathbf{f}, \lambda)$ | 5 |
| 2.4.2 | Differential visibility $V(\mathbf{f}, \lambda)/V(\mathbf{f}, \lambda_0)$ | 6 |
| 2.4.3 | Astrometric phase $\Phi_{SC}(\mathbf{f}, \lambda) - \Phi_{FT}(\mathbf{f}, \lambda)$ | 6 |
| 2.4.4 | Differential phase $\Phi(\mathbf{f}, \lambda) - \Phi(\mathbf{f}, \lambda)$ | 6 |
| 2.4.5 | Closure phase $\Phi_{ijk}(\mathbf{f}, \lambda)$ | 6 |
| 2.5 | Image reconstruction | 7 |
| 2.6 | GRAVITY characteristics | 7 |
| 2.7 | GRAVITY performances | 7 |
| 3 | GRAVITY working principles | 7 |
| 4 | Current status of GRAVITY | 9 |
| 4.1 | Offered modes | 10 |
| 4.2 | Service and Visitor Modes | 12 |
| 5 | Proposing observations | 13 |
| 5.1 | Proposal guidelines | 13 |
| 5.1.1 | Guaranteed time observation objects | 13 |
| 5.1.2 | Time critical | 14 |
| 5.1.3 | Calibration sequence and total time requested | 14 |
| 5.1.4 | Field of View | 14 |
| 5.1.5 | Complex fields | 15 |
| 5.1.6 | Bright objects | 15 |
| 5.2 | Choice of the GRAVITY configuration | 15 |
| 5.2.1 | Quadruplet | 15 |
| 5.2.2 | Wavefront sensor configuration | 15 |
| 5.2.3 | Observing modes: single-field, dual-field or dual-field wide | 15 |
| 5.2.4 | Optical set-up: spectral resolution, split or combined polarisation | 17 |
| 6 | Preparing the Observations | 17 |
| 6.1 | Standard observation sequence | 18 |
| 6.2 | OB continuation | 18 |

| | |
|--------------------------------------|-----------|
| 7 Calibration Plan | 19 |
| 7.1 Summary | 19 |
| 7.2 Calibrator Stars | 19 |
| 8 Bibliography | 21 |
| 9 Glossary | 21 |
| 10 Acronyms and Abbreviations | 23 |

1 Introduction

GRAVITY is a four-telescope beam combiner for the Very Large Telescope Interferometer (VLTI) operating in the K-band. It is equipped with various subsystems in order to precisely correct and control the incoming wavefront from the astronomical source via the telescopes to the GRAVITY beam combiner. These GRAVITY sub-systems include a fringe-tracker, an IR wavefront sensor (with the UTs only), a polarisation control system, a pupil-guide and field-guide system. These systems interact and work in harmony with the VLTI.

GRAVITY forms spectrally dispersed interference fringes of either a single astronomical source (single-field) or of two sources simultaneously (dual-field and dual-field wide). In dual-field mode the two sources are required to have a separation less than 2 arcsec when observing with the Unit Telescopes (UTs), or less than 4 arcsec with the Auxiliary Telescopes (ATs) of the VLTI. In dual-field wide mode the two sources need to have a separation less than 30 arcsec (for both UT and AT observations). Fringes are produced in two separate channels, the fringe-tracker (FT) channel and the science (SC) channel. The science channel records the entire K-band at one of the three implemented spectral resolutions of $\mathcal{R} \sim 22$, 500 and 4000. The FT spectrometer always operates at low spectral resolution ($\mathcal{R} \sim 22$).

When observing in dual-field and dual-field wide, one of the two sources is injected into the FT channel and its fringe pattern is analysed at a frequency of approximately a kHz. The fringe position in the FT is used in real-time to correct for the atmospheric and instrumental piston (i.e. a residual optical path difference between beams) by modulating piezo mounted mirrors within the instrument. The FT star thus allows longer detector integration times in the science channel without compromising the contrast of the fringe pattern. GRAVITY science observations are always assisted by FT observations. In single-field, the FT channel and SC channel receive light from the same object.

GRAVITY provides access to interferometric quantities such as absolute and differential visibility, spectral differential phase and closure phase, as well as the differential phase between the two sources in dual-field. These quantities allow reconstructing images at a spatial resolution that can reach 2 mas (depending on the VLTI baselines chosen), as well as time-resolved differential astrometry per spectral bin at the exquisite accuracy of a few tens of μas .

1.1 Scope

This document is intended for science users of GRAVITY during Phase 1 (P1, call for proposals) and Phase 2 (P2, preparation of the observations) of the ESO observation procedure. It gives an overview of the instrument and the way it can be used in pursuing certain astrophysical observations, especially those that require milli-arcsecond spatial resolution.

1.2 Current state and recent changes

- From P114, MACAO will be decommissioned from UT operations and replaced by GPAO (GRAVITY+ Adaptive Optics) with natural guide star (NGS). This comes with new (brighter) limits for AO guiding.
- Since P113, GRAVITY-Wide mode is now offered in LOW spectral resolution, in addition to MEDIUM and HIGH, for target with good astrometric precision.
- Since P112, the GRAVITY acquisition templates for both the single-field and dual-field mode are split into separate templates for on-axis and off-axis observations. The use cases for these new templates are described in detail in Section 5.2.3.
- GRAVITY can be requested with both ATs (using NAOMI) and UTs (using MACAO/GPAO or CIAO) as feeding telescopes (and adaptive optics systems). Visitor, Designated Visitor,

and Service Mode observations are offered. The limiting magnitudes of the instrument are advertised on the [GRAVITY Instrument Description webpage](#). The instrument can be used as spectro-imager in single-field, dual-field, and dual-field wide mode, and in low, medium and high spectral resolution. In addition, users are advised not to use low spectral resolution in single-field, since the FT already provides low resolution data on the science target.

- If you are interested in using the astrometric mode we invite you to have a look at the following articles: [Gravity collaboration, 2017, A&A 602, A94](#) and [The Messenger 170, 10](#). In addition, if you need help with the preparation of GRAVITY astrometric observations you can contact the [ESO Helpdesk](#) well in advance of the proposal deadline. To request such observations, **astrometry** must be selected as the type of interferometric observation during the preparation of the observing runs of a proposal.
- ESO has implemented an imaging scheme to optimise operations for aperture synthesis imaging with VLTI instruments using the ATs. More information on this scheme can be found in the [Call for Proposals](#) and the [VLTI user manual](#).

Before starting a GRAVITY proposal, users are advised to familiarise themselves with the [general aspects of the VLTI](#) as well as to consult the [ESO GRAVITY web pages](#) for any late information that could not be included in this manual.

1.3 Contents of the manual

Sect. 2 puts GRAVITY within the ESO context and addresses how GRAVITY as an astronomical instrument can be helpful for a science project. In order to give some background to users with little experience in optical interferometry, the section also presents a brief overview of its principles. Sect. 3 provides a technical, but basic, description of the instrument. The user is advised to read this section carefully in order to obtain a good idea of the instrument's capabilities. A reference to instrument specifics to be kept in mind while planning an observing programme is provided in Sect. 4. ESO guidelines for the preparation of a proposal for GRAVITY time is presented in Sect. 5. Sect. 6 provides the basic and ESO general information needed to prepare an observing programme. Finally, Sect. 7 presents the current calibration plan for GRAVITY observations.

1.4 Contact Information

This is a document that evolves continually, as the instrument is continuously improved and optimised. The manual is updated according to changes in Paranal operations of GRAVITY or on request by the GRAVITY user community. Questions related to proposal preparation, service mode, and visitor mode observations should be addressed via the contact form at [ESO Operations Helpdesk](#). Further information can be found on the [GRAVITY homepage](#). Any GRAVITY user should visit the instrument's home page on a regular basis in order to be informed about the current instrument status and updated developments.

2 Context

This section provides the context of the instrument from a science and ESO instrument suite point of view. It expands on the observables delivered by the instrument and how these could fit your science goals.

2.1 Is GRAVITY the right instrument for your science programme?

The instrument GRAVITY is designed to deliver high angular resolution information (on milli-arcsecond scale) on celestial sources by coherently combining the light from four telescopes. The spatial resolution is reached owing to the telescope baselines of the VLTI. The user is referred to the [VLTI Configurations Overview](#) for the offered telescope configurations, their baseline lengths and position angles. Currently, GRAVITY is offered in conjunction with either the Auxiliary Telescopes (ATs) or the Unit Telescopes (UTs).

GRAVITY has three spectral settings. For each setting it delivers interferometric quantities over the same wavelength range covering the near-IR K-band. For new VLTI users, it is good to realise that interferometric instruments like GRAVITY do not return a “mirror image” of a luminous source on the sky. Instead, such instruments combine pair-wise the light coming from individual telescopes which creates fringes between each telescope pair (see [Figure 1](#) for an example of the fringes produced by GRAVITY). Each fringe system per baseline is characterised by a fringe contrast and phase. These two quantities are directly related to the brightness distribution of the celestial object according to the Van Cittert-Zernike theorem.

GRAVITY can probably bring your science programme valuable information which any other ESO instrument cannot if your target:

- has a characteristic size in the range of 2 to 30 mas (milli-arcseconds),
- is brighter than $K = 10.0^m$, or
- is brighter than $K = 17.5^m$ and has a reference star brighter than $K = 10.5^m$ within $2''$ (in dual-field wide the separation can be $30''$ with the limiting science target magnitude of $K = 17.0^m$).

The [GRAVITY public webpages](#) detail the atmospheric conditions for the limiting magnitudes mentioned above.

2.2 GRAVITY and other ESO instruments

An interferometric instrument like GRAVITY is sensitive to luminous structures with a size-scale corresponding to the spatial frequency λ/B , where B is the (projected) baseline, i.e. the projected separation between the two telescopes used to combine the light. A range of baselines lengths and position angles are required to probe the geometry at different size scales and directions. The largest size-scale that can be probed is given by the shortest baseline which is limited by the smallest separation of two telescopes. Complementary spatial information at larger spatial scales by means of single dish UT observations can be obtained with other ESO facilities, such as [SPHERE](#) or [ERIS](#). These instruments deliver AO assisted diffraction-limited images in the same wavelength domain as GRAVITY. ERIS also performs integral field spectroscopy at the same spectral resolution as GRAVITY with a Field of View (FoV) between $0.8'' \times 0.8''$ and $8'' \times 8''$.

In addition to GRAVITY, the VLTI currently offers two other interferometric instruments that combine four beams, [PIONIER](#) and [MATISSE](#). PIONIER operates in the H-band at low spectral resolution. It provides a 30% higher spatial resolution for continuum observations at shorter wavelengths. MATISSE works at longer wavelengths in the L-, M- and N-bands, that is between 3.2 and $13.0 \mu\text{m}$. GRAVITY, PIONIER and MATISSE are all fed by the same VLTI infrastructure. Consequently, many aspects of the observation preparation and scheduling procedures are similar. Please, visit the [instrument pages](#) that detail the capacities of the ESO suite of instruments.

2.3 Optical interferometry basics

For the users who have little background in optical interferometry and would like to use GRAVITY, a brief and basic summary is provided here of what optical interferometry does and can. For a



Figure 1: One raw GRAVITY frame of the science channel. Wavelength runs horizontally. In contrast to other beam combiners, GRAVITY does not record entire fringe packets but only four points on the central fringe (i.e. the so-called ABCD method of fringe detection). For each polarisation, each pair of telescopes yields thus 4 spectra. The fringe can be seen by comparing spectra pertaining to the same pair of telescopes. The total number of spectra is thus 24: 6 pairs of telescopes, 4 points (*viz.* A, B, C, D) per pair.

didactic description of the basics of this technique we refer to the proceedings of the various ESO VLTI schools, for example the [EuroSummer School “Observations and Data Reduction with the VLT Interferometer”](#), *New Astronomy Reviews*, 2007, Volume 51, Issue 8-9.

The contrast and phase of monochromatic fringes obtained on a celestial source with a telescope baseline B and light of wavelength λ yield the amplitude and phase of a Fourier transform component of the source brightness distribution at the spatial frequency $f = B/\lambda$. If the full Fourier transform is sufficiently sampled, i.e. the spatial power spectrum of the source’s brightness distribution is sampled at many different spatial frequencies in the (u, v) plane (so called after the usual variables for the spatial frequencies) then an inverse Fourier transform yields a model independent reconstruction of the source brightness distribution at the wavelength λ and an angular resolution λ/B_{\max} . There are three ways to collect and sample the Fourier transform of spatial information in order to assess the geometry of the source: 1) obtain data on different baselines sextuplets 2) rely of the natural “super synthesis” by earth rotation and 3) the fact that GRAVITY records data simultaneously in many spectral channels.

An interferometric observing programme does not necessarily aim for image reconstruction. It should be well argued in the phase1 proposal when the science of a programme critically depends on the reconstruction of a high resolution image. The observables produced by an interferometric instrument such as GRAVITY already allow very detailed analysis of a physical phenomenon in or near an astronomical source, without the need to fill up the (u, v) plane to a high degree. There are different observables, which can be grouped as follows:

- The visibility amplitude is related to the projected size of an object along the projected baseline vector. The morphology of the object can therefore be retrieved through modelling of the brightness distribution.
- The absolute phase is directly measurable by GRAVITY only in dual-field mode, i.e. when simultaneously fringe-tracking on a source within the VLTI field-of-view which is not the science target (note that in the dual-field wide mode measuring the absolute phase is not possible). On the other hand, spectro-differential phase (phase difference between spectral channels) and closure phase (the phase of the so called bispectrum) are always measurable. The closure phase and the differential phase are powerful tools to investigate asymmetry in the source geometry. Furthermore, the absolute phase accessible in dual-field mode constitutes a very accurate measurement of the differential astrometry between the FT and SC targets.

It is important to note that the wavelength dispersion gives spatial information of two different kinds. On the one hand, there is the *spectral information* which allows to study the characteristic size of emission line regions, absorption line regions, e.g. with respect to the continuum emission. On the other hand, the wavelength plays a role because different wavelengths have different spatial resolutions: B/λ . In other words, the spectral dispersion helps to fill up the (u, v) plane. One should keep in mind these two complementary roles of the wavelength dispersion.

2.4 GRAVITY observables

The GRAVITY instrument delivers the following interferometry observables for each of the three spectral resolutions provided by the instrument, *viz.* 22, 500 and 4000, and for the full instrument wavelength range (1.98 to 2.40 μm):

- The absolute visibility in each spectral channel (the dual-field wide mode only provides relative measures);
- The spectral differential visibility, i.e. the ratio between the visibility in each spectral channel and the visibility in a reference spectral channel (average of several other channels for example);
- In dual-field mode, the absolute phase (in each spectral channel) using the FT source as reference. This quantity contains the astrometry of the SC source (relative to the FT reference) and encompasses the information contained in the closure phases and the differential phases below;
- The spectral differential phase, i.e. the difference between the phase in a certain spectral channel and the phase in a reference channel;
- The closure phase, being the phase of the bispectrum computed in each spectral channel. The bispectrum is the product of three complex visibilities along a closed telescope triangle. The closure phase is therefore theoretically equal to the sum of the three phases along the three baselines. This quantity is independent from atmospheric perturbations.

2.4.1 Absolute visibility $V(\mathbf{f}, \lambda)$

A single visibility measurement on a single baseline can constrain the equivalent size of a partially resolved source for an assumed morphology, e.g. a uniform disk or a ring. Visibility measurements at several spatial frequencies (obtained either through Earth rotation, at different wavelengths or by different telescope combinations) constrain strongly the equivalent size and can provide information on the geometry of the emitting structure. Visibility measurements should be carefully calibrated by means of calibrator stars (see Sect. 7).

2.4.2 Differential visibility $V(\mathbf{f}, \lambda)/V(\mathbf{f}, \lambda_0)$

Certain science programmes have an interest in variations of a source size as function of wavelength. For example, a structure which emits strongly in a certain spectral transition (a stellar wind) relative to the continuum emission of an altogether different physical structure (a star). The measurement in the spectral line can be calibrated by those of the continuum and the knowledge of the absolute visibility is not required, just the ratio between the visibility at a given wavelength and a reference channel.

Another application of the differential visibility is the study of objects with a characteristic angular size of the order $\lambda^2/B\Delta\lambda$ ($\Delta\lambda$ is the wavelength range): the visibility will vary inside the recorded band due to the super-synthesis effect. This is, for example, an appropriate tool to detect and characterize binaries with separation $a \sim \lambda^2/B\Delta\lambda$.

2.4.3 Astrometric phase $\Phi_{SC}(\mathbf{f}, \lambda) - \Phi_{FT}(\mathbf{f}, \lambda)$

In dual-field mode, i.e. when the FT reference star is distinct from the SC target and still very close to the science target, GRAVITY provides a direct measurement of the science target's phase by using the FT source as a phase reference (note that this only refers to dual-field mode, not dual-field wide). Clearly, the nature of the FT source needs to be known. This quantity constitutes a direct measurement of the differential astrometry between the photocenters of the two targets. For this quantity to be meaningful one or several binary calibrators must be observed immediately before or after the science observations and the GRAVITY metrology must run continuously between the calibration and science observations. Alternatively, if the two targets are bright enough for fringe-tracking, the two fields should be exchanged ("swapped") during the science observation in order to calibrate the metrology directly on the science pair. Assuming that the FT reference is point-like, then $\Phi_{FT}(\mathbf{f}, \lambda)$ is 0. Beware that if the FT reference contains asymmetric structure, then $\Phi_{FT}(\mathbf{f}, \lambda)$ is not necessarily 0 nor even constant.

2.4.4 Differential phase $\Phi(\mathbf{f}, \lambda) - \Phi(\mathbf{f}, \lambda_0)$

Because the instrument delivers spectrally dispersed fringe information, one can measure variations of the phase with wavelength. The principle is exactly the same as in astrometry, except that the reference is the source itself. The most remarkable aspect of this phase variation is that it yields angular information on objects which can be much smaller than the interferometer resolution limit. This results from the capacity to measure phase changes much smaller than 2π (i.e. 1λ). When the object is unresolved, the phase variation $\Phi(\mathbf{f}, \lambda) - \Phi(\mathbf{f}, \lambda_0)$ yields the variation with wavelength of the object photocenter. This photocenter variation is a powerful tool to constrain the morphology and the kinematics of objects where spectral features result from large scale (relatively to the scale of the source) spatial features. Note that if this is attempted over large wavelength ranges the atmospheric effects have to be corrected in the data interpretation.

2.4.5 Closure phase $\Phi_{ijk}(\mathbf{f}, \lambda)$

The closure phase, the sum of the phases of the 3 baselines inside a triangle, is independent from any atmospheric and instrumental phase offsets. It is therefore a very robust quantity in terms of calibration stability. In addition, with 4 telescopes, there are a total of six phases and four closure phases (per spectral channel). Closure phase contains therefore a significant fraction of the total phase information.

2.5 Image reconstruction

By obtaining a dense (u, v) filling of an astronomical source, one can consider to invert the measured Fourier components in order to create an approximation of the object brightness distribution on the sky. In order to get a meaningful image it is important to maximise the number of spatial frequencies in the (u, v) plane. Several software packages have been specifically developed for optical interferometry to reconstruct or invert the image coping with a sparse (u, v) coverage and incomplete phase information. For now, it is the user's initiative to pursue image reconstruction of extensive GRAVITY datasets.

2.6 GRAVITY characteristics

The main characteristics of GRAVITY are summarised in Table 1. For details on the offered modes see Sect. 4, as well as the [GRAVITY web pages](#) for the latest information.

2.7 GRAVITY performances

The precision of the interferometric phase and visibility amplitude in long science exposures is a function of the source brightness and the fringe-tracking residuals. For good conditions with fringe-tracking residuals smaller than 300 nm, the precision of the absolute visibilities is $\sim 0.5\%$, and about 1° for the phase (see [Gravity Collaboration 2017, A&A 602, id. A94](#)).

The minimum visibility for which the instrument can still track fringes reliably is about 5%. On the ATs, the science channel will reach saturation for the minimum DIT at $K = 1^m$ in medium spectral resolution and at $K = -2^m$ for high spectral resolution. Observations in high spectral resolution and split polarisation up to $K = -4^m$ have been achieved and can be proposed in that set-up.

With the UTs (from P114), GRAVITY operates in conjunction with the GPAO or CIAO adaptive optics systems. GPAO (GRAVITY+ Adaptive Optics) works at visible wavelength and has a limiting magnitude of $V/G = 12.5^m$. Alternatively, CIAO (Coudé Infrared Adaptive Optics) is an infrared adaptive optics system. Operational limits of GPAO and CIAO for on- and off-axis guiding as well as criteria to decide on which system to choose can be found in the [VLT user manual](#).

Before P114 and the installation of GPAO, GRAVITY operates in conjunction with the MACAO adaptive optics systems. MACAO (Multi-Application Curvature Adaptive Optics) is a curvature adaptive optics system working at visible wavelength with a limiting magnitude of $V = 15^m$.

With the ATs, GRAVITY operates in conjunction with the New Adaptive Optics Module for Interferometry, NAOMI. Its limiting magnitude is $V \sim 12.0^m$. Details on NAOMI can also be found in the [VLT user manual](#).

GRAVITY is not foreseen to operate with 3 telescopes or less.

3 GRAVITY working principles

The goal of the GRAVITY design is to provide a largely self-contained instrument for precise narrow angle astrometry and phase referenced imaging of faint targets in K-band. The following figures and diagrams illustrate the GRAVITY concept for the example of observations of the Galactic Center with the UTs (see Figs. 2 and 3). This particular example is chosen because it covers most of the operational modes of the instrument. For clarity, only two of four telescopes, i.e. one out of six baselines are shown. A block diagram depicting the various light paths and components of the instrument is shown in Fig. 4.

A bright wave front reference star (IRS7, $5.57''$ separation, $K = 6.5^m$) outside the $2''$ Field of View of the VLT is picked up by the UT Coudé star separator (STS) and imaged onto the GRAVITY IR **wavefront sensors** CIAO located in each of the UT Coudé rooms. This bright reference star

Table 1: GRAVITY characteristics

| Description | Specification |
|------------------------------------|--|
| Number of beams | Four |
| Spectral coverage | K-band (1.98 – 2.40 μm) |
| Spectral resolutions | $\mathcal{R} \sim 22$ $\mathcal{R} \sim 500$ $\mathcal{R} \sim 4000$ |
| Instrument contrast | 5% |
| Instrument throughput ¹ | $\sim 20\%$ |
| Observables: | |
| Visibility | $V(\mathbf{f}, \lambda)$ |
| Differential visibility | $V(\mathbf{f}, \lambda)/V(\mathbf{f}, \lambda_0)$ |
| Phase (dual-field mode only) | $\Phi_{SC}(\mathbf{f}, \lambda) - \Phi_{FT}(\mathbf{f}, \lambda)$ |
| Differential phase | $\Phi(\mathbf{f}, \lambda) - \Phi(\mathbf{f}, \lambda_0)$ |
| Closure phase | $\Phi_{ijk}(\lambda)$ |

¹ Derived during commissioning and corrected for VLTI transmission

thus serves as an off-axis AO reference star. The wavefront correction is applied using the MACAO deformable mirrors. GRAVITY can also be used with the generic MACAO optical wavefront sensors on the UTs. When observing with the ATs, the adaptive optics correction is performed by NAOMI. The 2'' telescopic Field of View of the VLTI (UT case; 4'' on the ATs) contains both the science target (Sgr A*) and the phase reference star (IRS16C, 1.23'' separation, $K = 9.7^m$). Both objects are re-imaged via the main VLTI delay lines onto the GRAVITY Beam Combiner Instrument (BCI). Note that GRAVITY can operate in single-field, dual-field, and dual-field wide mode. In the single-field case, the SC target also serves as FT reference star and the light is split 50%-50% between the two channels. Dual field-wide allows the extension of the separation between the FT and SC object by merging the two fields initially separated by the VLTI Star Separators. In dual-field wide the separation between the FT and SC object can be up to 30''.

Laser guiding beams are launched at the star separator and telescope spiders to trace tip-tilt and pupil motion, respectively, within the VLTI beam relay. The GRAVITY Beam Combiner Instrument has internal sensors and actuators to analyse these beams and to apply the corresponding corrections. Longer-term drifts of the object are compensated with the help of the internal **acquisition camera** (working at H-band). This camera also analyses the signal from the pupil-guiding laser beams launched at the telescope spider.

In dual-field mode, the **fibre coupler** then splits the VLTI field containing the two stars and they are injected into two separate mono-mode fibres, one for the science channel and one for the fringe-tracker channel. A rotatable half-wave plate is used to control the linear polarisation of the light. In single-field mode, a beam splitter is used instead to inject half of the light from the same source into each mono-mode fibre. A **fibre control unit** including rotators and stretchers align the polarisation for maximum contrast, and compensate the differential OPD between the phase reference star and science object caused by the angular separation on sky. The two beam combiners are implemented in **integrated optics** chips with instantaneous fringe sampling (following the so-called ABCD method). The bright FT reference star (IRS16C, 1.23'' separation, $K = 9.7^m$) feeds the **fringe-tracker**, which measures the phase and group delay from five spectral channels across the K-band. The OPD correction is applied to a small internal piezo-driven mirror that stabilises the fringes of both the

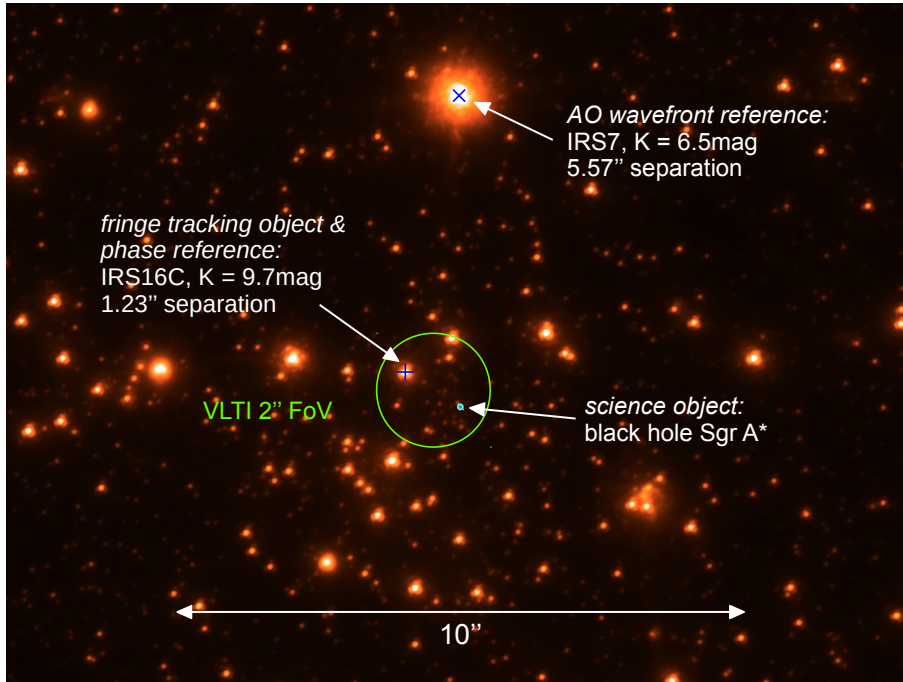

Figure 2: NACO K-band image of the Galactic Center illustrating the required celestial configuration for GRAVITY AO assisted observations. See text for details.

reference star and the faint science object (S2 or Sgr A*) at high frequency. To efficiently remove any incoherent flux and possible bias of the measurements, the piezos are additionally modulated for each exposure of the science detector with a repetitive pattern of 4 or 16 exposures (for details on the fringe-tracker, see [Lacour et al. 2019, A&A 624, A99](#)).

The **science spectrometer** is optimised for longer, background limited integration times of faint objects, and offers a variety of operation modes, including broad band (ten spectral pixel) observations and low ($\mathcal{R} \sim 500$) and moderate ($\mathcal{R} \sim 4000$) resolution spectroscopy. Both fringe-tracker and science spectrometer can be used with a Wollaston prism to split and simultaneously measure two linear polarisation states. The differential OPD between the science and reference beam is measured with a **laser metrology system**. The laser light is back-propagated from the GRAVITY beam combiners covering the full beam up to above the telescope primary mirror. The metrology signal is encoded via phase-shifting interferometry and measured by photodiodes mounted to the telescope spider arms. GRAVITY provides simultaneously for each spectral channel the visibility of the reference and science object, and the phase difference between reference and science object.

The **calibration unit** simulates the light from two stars and four telescopes, and provides all functions to test and calibrate the Beam Combiner Instrument. All functions of the instrument with the exception of the calibration unit, the metrology receivers, and the guiding lasers are implemented in a cryostat for optimum stability, cleanliness, and thermal background suppression: the GRAVITY Beam Combiner Instrument (BCI). The BCI is installed in the VLTI interferometric laboratory. Figure 5 shows a picture of the open cryostat with the inside subsystems labelled.

4 Current status of GRAVITY

Since P98, GRAVITY is offered to the community in open time. GRAVITY can be used with either the UTs or the ATs and in Visitor, Designated Visitor, and Service Mode. Starting P110 three observing modes single-field, dual-field, and dual-field wide are offered. GRAVITY is offered in all

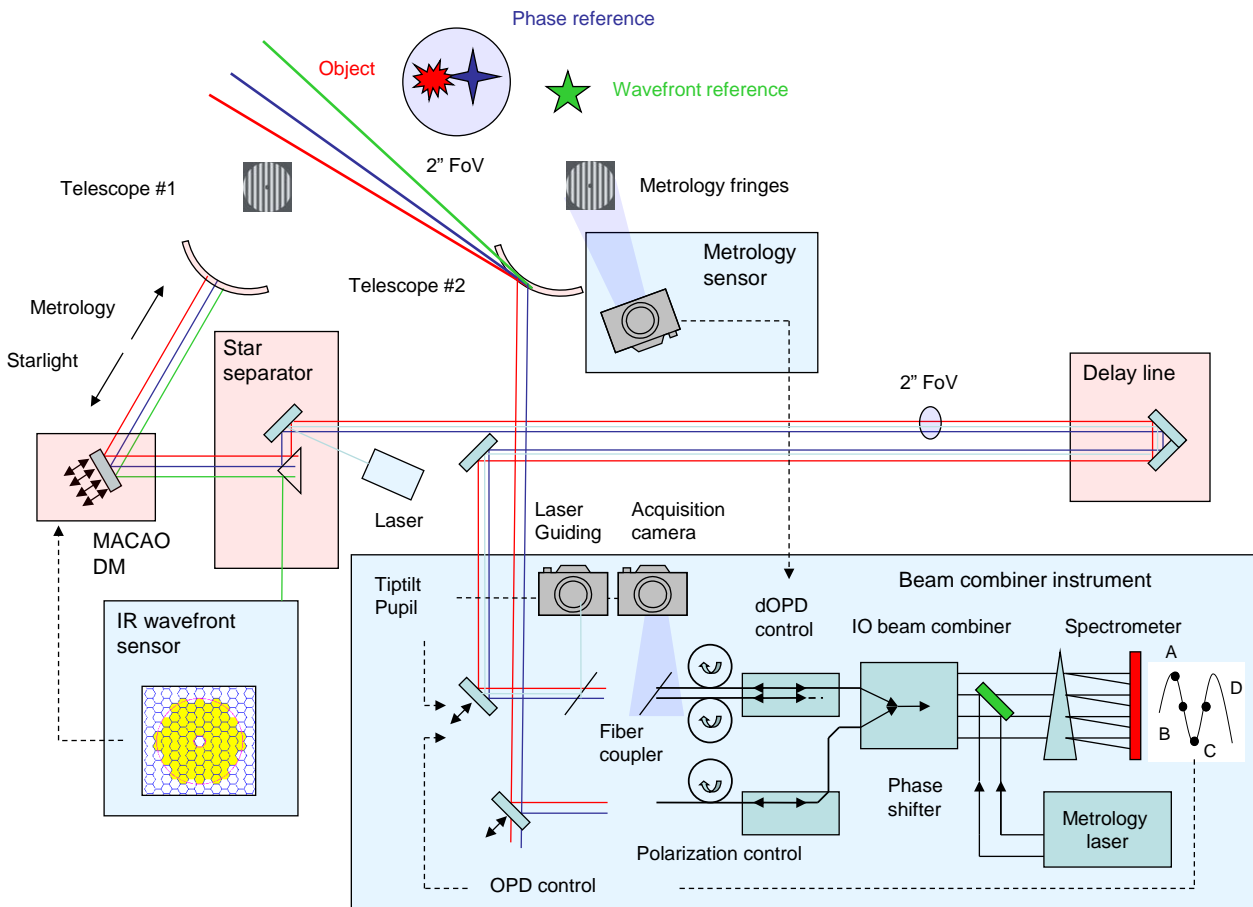

Figure 3: Working principle of GRAVITY with the UTs.

three spectral resolutions with the following constraints/remarks. Dual-field wide is not offered in low resolution mode. In addition, users are advised not to use the low spectral resolution in single-field, since the FT already provides low resolution data on the science target. The single-field, low spectral resolution setting should only be used for the calibration of dual-field low resolution observations.

4.1 Offered modes

The instrument can be used either for so-called *snapshot*, *imaging*, *time-series*, or for *astrometric* observations. For snapshot, imaging, and time-series observations, GRAVITY acquires interferometric fringes in single-field, dual-field, or dual-field wide mode from which visibilities, differential phases and closure phases can be extracted. These can then be used to infer properties of the wavelength-dependent brightness distribution of the source or to reconstruct an image (see Sect. 2). For astrometric observations, on the other hand, the instrument must be used in dual-field mode in order to measure the astrometric phase between the FT source and the SC target (see Sect. 2.4.3). This absolute phase can then be used to obtain a very accurate measurement of the differential astrometry between the two targets. Note that GRAVITY always observes with four telescopes (UTs or ATs) and with fringe stabilisation by means of the GRAVITY fringe-tracker. The interferometric quantities can be obtained from the data by means of the [ESO GRAVITY pipeline](#). More details on calibrations and calibrator stars can be found in Sects. 5.1.3 and 7.

The user has the liberty in choosing the set-up of the instrument according to their science requirements. In particular the user has to choose the setting of the following instrument functions:

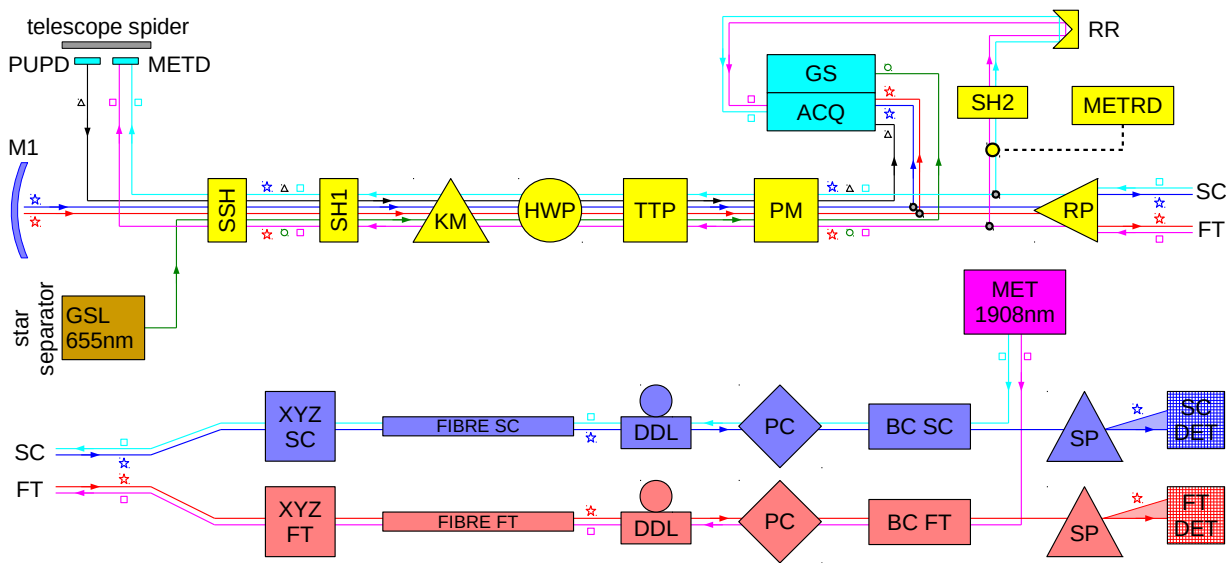

Figure 4: Block Diagram of GRAVITY. The light paths of the science target (blue ☆), of the fringe-tracker object (red ☆), the pupil beacons (black △), the guiding system laser (green ○) and the metrology laser from the science channel (cyan □) and from the fringe-tracker (magenta □). PUPD: pupil beacon diode, METD: metrology diode, GSL: guiding system laser, SSH: safety shutter, SH1: entrance shutter, KM: K-mirror, HWP: half wave plate, TTP: tip tilt piston mirror, PM: pupil actuator mirror, GS: guiding system sensor, ACQ: acquisition camera, SH2: shutter for retro-reflector, RR: retro-reflector, METRD: fibre coupler diode, RP: roof-prism, XYZ SC: x,y,z stage of science combiner fibre, XYZ FT: x,y,z stage of fringe-tracker fibre, FIBRE SC: science combiner fibre, FIBRE FT: fringe-tracker fibre, DDL: differential delay lines, PC: polarisation controller, BC SC: science beam combiner, BC FT: fringe-tracker beam combiner, SP: spectrometers, SC DET: science combiner detector, FT DET: fringe-tracker detector, MET: metrology laser diode.

- **Polarisation:** both settings for the Wollaston prism are offered, i.e. the so-called split and combined. In split mode, both polarisations are recorded separately. So far, it has not been possible to detect any significant difference in visibility accuracy between the two settings. The split setting would be appropriate for bright objects for which high accuracy visibilities are requested. The combined setting is appropriate for fainter objects in order to not lose half of the precious light. If one can afford to go in split mode (i.e. enough SNR) then the split mode should be requested. The polarisation mode of the SC and FT channels will be the same during observations.
- **Field:** three settings are offered, i.e. single-field, dual-field and dual-field wide (see also Section 5.2.3). In single-field, the science source is also the FT source. The K-band light is split 50%-50% between the FT and SC channels. In dual-field, there are two set-ups depending on the distance of the FT and SC objects. For separations $< 0.6''$ with the UTs or $< 2.7''$ with the ATs, the same 50% beam-splitter (anti-reflection coated part of a roof-prism) as in the single-field case can be used (“dual-field on-axis”). For larger distances ($> 0.27''$ with the UTs or $> 1.17''$ with the ATs), $\sim 100\%$ of the light of each source can be injected into the fibres using the reflective part of the roof-prism working like a roof-top mirror (“dual-field off-axis”). With the UTs, the maximum separation of the two targets is $2''$ due to the Field of View of the VLTI; with the ATs, the maximum separation is $4''$. Otherwise the sources will be vignetted. Note that there is an overlap between dual-field on-axis and off-axis modes. With separations $0.27'' - 0.6''$ for the UTs and $1.17'' - 2.7''$ for the ATs one can use either dual-field on-axis or

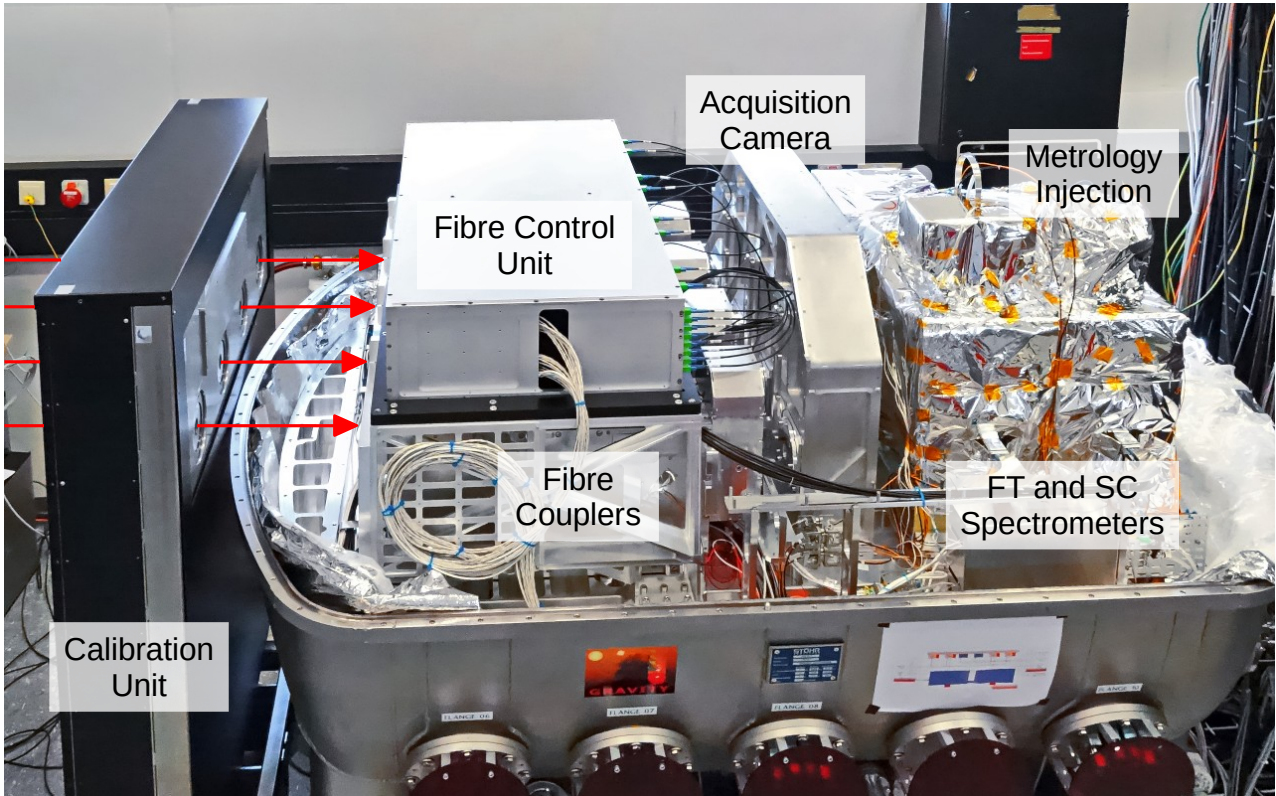

Figure 5: Overview of the cryostat of the Beam Combiner Instrument and its subsystems. The light from the four telescopes arrives from the left as indicated by the red arrows.

dual-field off-axis mode. More discussion on this can be found in Section 5.2.3. Dual-field wide allows the extension of the separation between the FT and SC object by merging the two fields initially separated by the VLTI Star Separators. In dual-field wide the separation between the FT and SC object can be up to $30''$. However, absolute calibration is currently not possible in the dual-field wide mode. For limiting magnitudes and magnitude difference between the two sources, we refer to the [GRAVITY instrument webpages](#). Carrying out astrometric observations implies using the dual-field on-axis or off-axis mode.

- Spectroscopic settings: GRAVITY in single-field and dual-field are offered in low (22), medium (500) and high (4000) spectral resolution. Dual-field wide is currently not offered in low resolution setting and thus this mode can at the moment only be used in medium and high resolution. In addition, low resolution data from the fringe-tracker is always delivered together with the science data. Therefore, users are advised not to use low spectral resolution in single-field, since the FT already provides low resolution data on the science target. The fringes of the GRAVITY fringe-tracker are reduced by the data reduction pipeline and can be used for science.

4.2 Service and Visitor Modes

GRAVITY is offered in *Service Mode*, *Designated Visitor Mode*, and *Visitor Mode*. Normal programmes should be carried out in Service Mode such that observations can be scheduled flexibly depending on the prevailing observing conditions. Visitor Mode and Designated Visitor Mode observations should only be requested for particularly challenging observations, for non-standard observational procedures, or where real-time decisions are required. In those cases, the potential proposers should contact the the [User Support Department](#) (email: usd-help@eso.org) or directly the Instrument Scientist (email: gravity@eso.org) to clarify feasibility of the observations **before** submission

of a proposal. In any case, proposers requesting Visitor Mode should carefully justify their request. The Guaranteed Time Observation (GTO) by the GRAVITY consortium are always carried out in Visitor Mode. As for any other instrument, ESO reserves the right to transfer visitor programmes to service and vice-versa.

5 Proposing observations

Proposals should be submitted through the [Phase 1 web-based proposal submission system](#) (p1), which can be accessed from the following web address:

<https://www.eso.org/p1>

Carefully read the following information before submitting a proposal.

5.1 Proposal guidelines

Considering a target which has a scientific interest, the first thing to do is to check whether GRAVITY is the best suited instrument for the science goal (see Sect. 2.2). The reason for using GRAVITY has to be justified in the proposal beyond the statement that GRAVITY is the best instrument for the science case at hand. Especially for programmes not requiring high spectral resolution in the K band, such as continuum imaging, companion detection, or stellar size measurements, PIONIER may be a better option.

The second step is to determine whether or not the target can be observed with GRAVITY, and whether the capabilities of the instrument are met. Please note that the limiting magnitudes for GRAVITY observations depend on the atmospheric turbulence (seeing and coherence time) and sky transparency, and that appropriate weather conditions have to be requested during the Phase 1 proposal. The current magnitude and visibility limits for observations with GRAVITY can be found on the [GRAVITY instrument webpage](#).

Users are required to specifically address if the offered limitations are fulfilled. For example, if the objects to be observed are expected to be resolved, modelling of the expected visibilities and correlated fluxes should be carried out, in order to check that they fulfill the requirements, e.g. using the observation preparation tool [ASPRO](#). In any case, the typical visibility expected for a certain observational setup has to be provided in the field “Expected Visibility” in the *Observations* section of the proposal. In case the dual-field or dual-field wide mode is requested, the two components have to be specified separately including their magnitudes and positions in the *Targets* section of the proposal. The fringe-tracker object has to be attached as a reference target to the science object in the *Observations* section. The same procedure applies for the Coudé guide star, which can be either identical to the science or the fringe-tracker target, or a third object. If swapping is requested, both the SC and FT objects must fulfill the requirements for fringe-tracking. Proposals violating the limitations of the instrument will be rejected during feasibility assessment. For special set-ups and experiments, the instrument operating team should be contacted well in advance of proposal submission.

5.1.1 Guaranteed time observation objects

Check any scientific target against the list of guaranteed time observation (GTO) objects. This guaranteed time period covers the entire observing period. Also, make sure the target has not been reserved already. The list of GTO objects can be downloaded from: <http://www.eso.org/sci/observing/teles-alloc/gto.html>.

5.1.2 Time critical

For successful observations, it is very important that special scheduling constraints or other time-critical aspects are entered in the “Time Constraints” section for each observing run. See the [p1 help page](#) for details.

5.1.3 Calibration sequence and total time requested

For single-field and dual-field observations the user should use appropriate calibrator stars in terms of target proximity, magnitude and apparent diameter. For dual-field wide no absolute calibration is at the moment possible and therefore calibrator is not needed.

Ideally, the calibrator is within 10° on sky and within 0.5^m of the science object in both the K-band and the band used for Coudé guiding (R-band for NAOMI, V-band for MACAO and K-band for CIAO). Yet, during commissioning, the transfer function has shown to be stable for calibrators with a difference of 1.0^m . These numbers may become less stringent with an increased understanding of the instrument. Clearly, the calibrator is required to be as small as possible, again, ideally unresolved. The calibrator stars should be provided by the user with the submission of the Phase 2 material. To help the user to select a calibrator, a tool called “CalVin” is provided by ESO, see here: <http://www.eso.org/observing/etc/>.

GRAVITY is offered in fixed slots up to 60 minutes, or 90 minutes after approval of a waiver. Each science or calibrator OB typically takes 30 minutes to execute. Depending on the science case, any sequence of science (SCI) and calibrator (CAL) observations are possible, with the different OBs being grouped in a concatenation. More specifically this means the following sequences are possible: SCI only (when no absolute calibration of the visibilities is required/possible, e.g. always in the dual-field wide mode or in astrometric measurements where the two sources are swapped instead), CAL-SCI, SCI-CAL, SCI-CAL-SCI or CAL-SCI-CAL. All modes single-field, dual-field and dual-field wide will use the same length of the OB. While the dual-field and dual-field wide modes require a longer acquisition, they are more sensitive. Details on instrument calibration can be found in Section 7.

The total time required for an observing programme depends on the number of calibrated measurements needed to reach the science goals. For a single size measurement and a known geometry of the source, one measurement slot of 1 hour may be sufficient; to fully image a complex brightness distribution of one target, 20 hours or more using different telescope configurations may be necessary. The requested amount of time including overheads has to be justified in the respective section of the proposal. The justification should clearly address the question why the requested amount of time is required to reach the science goal. Especially if the proposal has the goal of imaging, the proposers are strongly advised to carry out an investigation on how many observations are required to achieve the targeted imaging fidelity. Furthermore it is advised to actually create the OBs required for the observations using the exposure times obtained with the ETC, and to use the execution times listed by the Phase 2 tool to estimate the actually required time, rather than providing general estimates of the overheads.

5.1.4 Field of View

GRAVITY is a dual-field instrument, which means that the acquired field with the target source will be split inside the instrument to follow two different beams (FT and SC). The maximum separation between the SC and FT fibres is limited by the VLTI Field of View (FoV) in the interferometric laboratory: $2''$ on the UTs, $4''$ on the ATs. Note that in dual-field wide larger separation of the FT and SC targets is possible (up to $30''$), but that is achieved by using the VLTI Star Separators and does not imply larger field of view. The FoV seen by each fibre is limited to the Airy disk of each individual aperture, i.e. 250 mas for the ATs and 60 mas for the UTs in K-band. For most

observations this will not have consequences but can be limiting the observations of objects that consist of several components e.g. binaries, stars with disk and/or winds, etc. that have a spatial extension equal or superior than the interferometric FoV. While such observations are not impossible, the observer will have to take into account this incoherent flux contribution in his data analysis.

5.1.5 Complex fields

When observing complex fields within a few arcseconds, it is necessary that the field contains a dominant, significantly brighter object for the AO or tip-tilt correction (see VLTI User Manual concerning the requirements of NAOMI, GPAO, MACAO and CIAO). In this case a clear finding chart must always be provided with the OBs.

5.1.6 Bright objects

On the ATs, the science channel will reach saturation for the minimum DIT at $K - 1^m$ in medium spectral resolution and at a K-band magnitude of $K = -2^m$ for high spectral resolution. Observations in high spectral resolution and split polarisation up to $K = -4^m$ have been achieved and can be proposed in that set-up. With the UTs, 2^m higher magnitude limits apply.

5.2 Choice of the GRAVITY configuration

5.2.1 Quadruplet

GRAVITY is offered in conjunction with either the UTs or the ATs. The ATs are movable in order to probe different ranges of spatial frequencies and hence achieve a better (u, v) coverage. Model-fitting programmes should be employed to study carefully which quadruplet is the most suitable to achieve the science goals. For complex or imaging programmes, it may be necessary to use several AT configurations. Note however that AT reconfigurations are executed only once every few weeks. The user has to assess whether this is an issue for fast evolving objects. Specific restrictions apply to which GRAVITY modes can be combined with certain AT configurations. Most importantly, dual-field (astrometric) and dual-field wide observations require all telescopes to be located on the same side of the delay line tunnel, limiting the allowed AT configurations such observations. For details on the offered VLTI AT telescope configurations, baseline lengths, position angles, we refer to the [VLTI Configurations Overview](#) and the [VLTI user manual](#).

5.2.2 Wavefront sensor configuration

GRAVITY on the UTs is used in conjunction with the optical AO system GPAO or the infrared AO system CIAO. GRAVITY on the ATs is used with the generic optical wavefront sensor on the ATs, NAOMI. For details on the AO systems and – in the case of the UTs – for guidelines on how to choose between GPAO and CIAO, see the [VLTI user manual](#). Note that prior to P114, GRAVITY will continue to use the old MACAO system before decommissioning activities.

5.2.3 Observing modes: single-field, dual-field or dual-field wide

The most important choice for the user, which defines the observing mode, is the dual-field vs. single-field choice. Most sources can only be observed in *single-field mode*, in which case a beam splitter is used by the fibre coupler to send half of the light to the fringe-tracker arm and the other half to the science channel. When a bright source is available up to $30''$ away from the science target, it is possible to fringe-track on this second object. Depending on the distance of the two objects there are three possible set-ups. Starting in Period 112 these different *dual-field mode* cases use their own acquisition templates:

1. *Dual-field on-axis*: If the separation is less than $0.6''$ for the UTs and $2.7''$ for the ATs, the dual-field mode can be used in the “on-axis” set-up. Here, the source is placed on the beam splitter as for the single-field mode and the light from the science and the fringe-tracking targets are picked up by moving the fibres accordingly. With this set-up, arbitrary low separations between the FT and SC objects can be achieved; for a separation of $0''$ (e.g. for calibration purposes) the set-up is identical to the single-field mode. In this set-up, less than 50% of the light of each object are injected into the fibres only, i.e. the throughput is reduced by about a factor of 2. This loss has to be taken into account for the limiting magnitudes.
2. *Dual-field off-axis*: For separations larger than $0.27''$ for the UTs and $1.17''$ for the ATs, the dual-field mode can be used in the “off-axis” set-up, where the source is placed on a roof-top mirror which separates the light from the science target and the fringe-tracking target and injects $\sim 100\%$ of the light of each source into the respective fibres. The limiting separation for this mode is set by the VLTI field-of-view, i.e., $2''$ for the UTs and $4''$ for the ATs.
3. *Dual-field wide*: For separations up to $30''$ it is possible to use the VLTI Star Separators to pick two separate targets that are later merged into the VLTI field of view and made available for GRAVITY observations similarly to the dual-field off-axis case. This means that dual-field wide allows the separation between FT and SC objects to be $2.0'' < \text{sep.} < 30.0''$ for the UTs and $4.0'' < \text{sep.} < 30.0''$ for the ATs. The performance of this mode strongly depends on the atmospheric conditions and the separation between the FT and SC target. Note also that currently absolute calibration is not possible in dual-field wide and the observations are carried out using only SCI observations and yielding only relative measures (differential visibilities and phases). More information on the GRAVITY dual-field wide mode can be obtained from [GRAVITY+ Collaboration 2022](#).

The illustration of the possible separations for the different dual-field modes is given in Fig. 6. The lower separation limit for the dual-field off-axis mode is set by the sharpness of the roof prism and the largest possible separation for the dual-field on-axis mode is set by the tip-tilt piston stroke. The largest possible separation for the dual-field off-axis mode is set by the VLTI field-of-view and for the dual-field wide mode by the atmosphere. The lower separation limit for the dual-field wide mode ($4''/2''$ on ATs/UTs) is not absolute and from the technical point of view smaller separations can also be used. However, as dual-field wide does not provide absolute calibrations, it is recommended to use dual-field off-axis when possible. In any case, with a waiver it is possible to use dual-field wide with smaller separations.

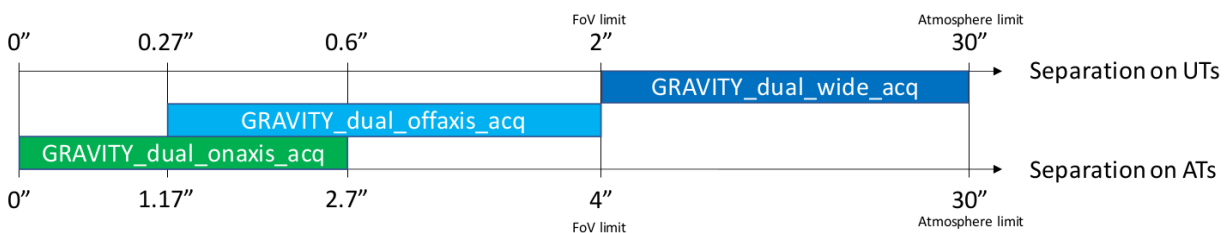

Figure 6: Possible target separations for the different dual-field acquisition templates: on-axis, off-axis and wide.

Starting Period 112 also the single-field mode has two separate acquisition templates: on-axis and off-axis. The *single-field on-axis* has the same behaviour as the old single-field template. The new *single-field off-axis* template will be used for GRA4MAT acquisition and when the user wants to observe a faint target and is only interested in using the fringe tracker to record data. In the latter case the science fiber is just placed on the sky and the target is observed only with the fringe tracker.

For a detailed description and the specifications of the fibre coupler we refer to [Pfuhl et al. 2014, SPIE 914623](#).

Astrometric measurements require the use of the dual-field mode. For information on the limiting magnitudes for all the modes see the [ESO public web-pages on GRAVITY](#). In case the dual-field or dual-field wide mode is requested, the two components have to be clearly specified during Phase 1. In particular, the fringe-tracker object will have to be attached as a reference target to the main science target (the object initially in the science combiner of GRAVITY) in the online tool for the preparation and submission of observing proposals when defining the planned observations.

5.2.4 Optical set-up: spectral resolution, split or combined polarisation

The optical set-up is defined by the spectral and polarimetric configuration of the instrument. The calibrator and science targets should be observed with the very same set-up and only one set-up can be used in a given OB.

For sensitivity reasons, the GRAVITY spectrometer concentrates all the flux of a single spectral line in less than 2 pixels (~ 1.5 pixels FWHM at high resolution, 1.8 pixels FWHM at medium resolution). In other words, GRAVITY is not Nyquist-sampled. This sampling is still sufficient to retrieve the position of a single isolated line to arbitrary precision, limited only by signal-to-noise and systematic effects. However, for more complex spectral energy distributions (e.g. velocity gradients in spectrally unresolved emission lines), the radial velocity accuracy of GRAVITY should be expected to be limited to one spectral channel (0.24 nm at high spectral resolution, 2.2 nm at medium spectral resolution). In some cases, analysing GRAVITY data together with integral field or long-slit spectroscopic data at higher resolution will help.

GRAVITY can operate in two polarimetric modes: the split and combined mode. Polarising effects in the VLTI give rise to a differential phase between the two polarisation states. This is compensated for in combined mode. In split mode, the fringes of the two polarisation states are recorded independently. Note, that this optical set-up is currently not foreseen to measure the intrinsic polarisation of the source.

6 Preparing the Observations

For all VLT instruments, an **Observation Block (OB)** is a logical unit specifying the telescope, instrument and detector parameters and actions needed to obtain a **single** observation. It is the smallest schedulable entity which means that the execution of an OB is normally not interrupted as soon as the target has been acquired. An OB is executed only once. If identical observation sequences are required (e.g. repeated observations using the same instrument setting, but different targets or at different times), a series of OBs must be constructed.

Because an OB can contain only one target or set of targets (e.g. combination of fringe-tracker and science target), science and associated calibration stars (cf. Sect. 7) should be provided as two different OBs. Thus each science object OB should be accompanied by a calibrator OB within a **concatenation**. These OBs should be identical in instrument set-up, having only different target properties (coordinates, magnitudes, etc.). It is especially important to have the same fringe tracker mode for the calibrator and science observations. However, the science detector exposure time (detector integration time, DIT) does not need to be the same in the science target and calibrator observations; the vfactor calculation removes different visibility losses due to different DIT. Still, it is recommended to use the same science detector DIT for both the calibrator and science target observations. Note also that the viscal workflow in the GRAVITY pipeline checks for the same setup, including the same science detector DIT, if needed this can be turned off by setting `force_calib` to `TRUE`.

For single-telescope instruments, OBs can typically be executed during the entire period an object is

visible or above a certain airmass in the night. In the case of interferometric instruments, the exact time an OB is executed is more critical, because the instant of observation define the location of the observation in the (u, v) plane.

6.1 Standard observation sequence

A standard observation with GRAVITY can be split in the several sub tasks:

1. Configuration: Set-up of the desired spectral resolution and polarisation mode;
2. VLTI acquisition: Slew telescopes to the target position on sky, slew the delay-lines to the expected zero-OPD position, use the STS to send the field to GRAVITY;
3. Acquire the GPAO, MACAO, CIAO or NAOMI guide star. As stated in the [VLTI user manual](#), the user has the possibility to use a guide star for the Coudé systems, different from the target. Refer to that manual for the limitations of this option.
4. Depending on the separation between the FT reference and the SC target, set-up the GRAVITY fibre coupler sub-system: rotate the field, position the beam or field splitter, move the fibres onto the two sources, preset the differential delay lines;
5. The operator may then check that the acquisition is correct using a finding chart;
6. Optimise flux injection in the FT fibre and optionally in the SC fibre; start the pupil guiding;
7. Search for fringes and close the FT loop, centre the fringes on the science detector (in dual field and dual field wide modes);
8. Start recording data according to DIT, NDIT and the number of object exposures.
9. Move the object(s) off the SC and FT fibres (i.e. so that no light from an astrophysical source enters the fibres) and record flux to estimate the sky level.

6.2 OB continuation

It is possible to repeat the science template in the OB. In dual-field mode, this allows for rotating the field by 180° , exchanging the role of the FT and SC targets (e.g. to study both members of a binary or to calibrate the metrology for astrometric measurements), or to move the SC fibre to another target using the same FT reference (e.g. to study two or more members of a star cluster). If the SC and FT objects are swapped, both objects must fulfil the limiting magnitude and visibility constraints of the fringe-tracker. In the dual-field wide mode it is not possible to swap the FT and SC objects.

Table 2: Calibration data required by the pipeline to fully reduce and calibrate science data. The calibrations marked in green are night time calibrations under the responsibility of the user; the other calibrations are day-time calibrations under the responsibility of Paranal Science Operations.

| Calibration | Template | Frequency | Duration | Pipeline Output |
|--------------|--------------------------------------|--|----------|--|
| Dark | <i>GRAVITY_gen_cal_dark</i> | daily | 1 min | DARK_SC/FT |
| Flat | <i>GRAVITY_gen_cal_flat</i> | daily* | 4 min | GAIN_SC/FT BAD_SC/FT PROFILE_SC/FT |
| Wavelength | <i>GRAVITY_gen_cal_wave</i> | daily* | 15 min | WAVE_SC/FT |
| P2VM | <i>GRAVITY_gen_cal_p2vm</i> | daily | 30 min | DARK_SC/FT GAIN_SC/FT BAD_SC/FT PROFILE_SC/FT WAVE_SC/FT P2VM_SC/FT |
| Dual-field | <i>GRAVITY_dual_obs_calibrator</i> | - after each metrology loss, - for visibility calibration, - at will of user | 30 min | VIS_SC_DUAL_CAL VIS_FT_DUAL_CAL VIS_DUAL_CAL |
| Single-field | <i>GRAVITY_single_obs_calibrator</i> | - for visibility calibration, - at will of user | 30 min | VIS_SC_SING_CAL VIS_FT_SING_CAL VIS_SING_CAL |
| Dispersion | <i>GRAVITY_gen_cal_disp</i> | monthly | 4 h | DISP_CAL |

* These calibrations are also part of the P2VM calibration template, *GRAVITY_gen_cal_p2vm*, and are hence not required if the P2VM template is used.

7 Calibration Plan

7.1 Summary

Table 2 summarises the calibration data used by the pipeline to fully calibrate the SC and FT data. The observatory will automatically provide the data in black during day-time calibrations; the user is responsible for requesting the data in green and providing the relevant OB. **The user needs only to provide the calibrator OB for the mode that is used: either single-field or dual-field. Dual-field wide is used in SCI only observations and no calibrator should be provided.**

7.2 Calibrator Stars

The calibrators will be used to estimate both visibilities and phases. The phase referencing can be difficult since we must know the level of asymmetry of the chosen calibrator. Binary or multiple objects, or asymmetric stellar envelopes could create difficulties. The GRAVITY calibrators have been chosen as close as possible to the single, symmetric, small star paradigm, in order to have a clean reference in particular for the phase. The observation of two calibrators instead of one may be useful in order to check how well the paradigm is fulfilled. The single and symmetric conditions are required in order to have a phase reference with a well-defined behavior. The average phase of the fringes obtained on a binary or asymmetric star changes with the orientation and length of the projected baseline, and can also change with time, e.g. due to orbital motion. A symmetric and single star will have a minimal (ideally zero) and stable intrinsic phase. Moreover, a small angular size of the reference object will improve the robustness of its phase to an intrinsic asymmetry (the smaller angularly, the smaller the phase for a given asymmetry level). A small angular size also is desirable to reduce the effect of the angular extension of the calibrator on the error bars of the visibilities.

For instance, let's consider the particular case of a calibrator with the same angular size as the scientific target. Its size is known a priori, as an example from surface brightness considerations, to an accuracy of 2%. Using this calibrator alone, it will be impossible to obtain the angular size of the scientific target with an accuracy better than 2%, due to the systematic nature of the a priori error on the calibrator size. Therefore, the smaller the calibrator, the smaller is the systematic calibration error.

Calibrator stars are stars with known angular diameters, yielding to the highest possible visibility, knowing that:

- fringes' SNR should be comparable between SCI and CAL.
- CAL should be as close as possible to SCI (ideally $\leq 25\text{deg}$ and similar airmass).
- CAL should be observable one hour before AND one hour after the SCI target. This is to ensure that it can be observed after or before the SCI if the later has been observed at the limit of its LST constraint. In the case of bracketed observations (i.e CAL-SCI-CAL) and impossibility to find a calibrator observable before and after a second calibrator should be used.

Considering that the choice of calibrator can be tailored to the actual specificities of the scientific goal, the users are responsible for the choice of their calibrators, and the creation of the subsequent OBs. ESO offers the CalVin tool¹ to chose the calibrator stars.

The observation of calibrator stars are used to measure the transfer function of the instrument, namely:

- visibility transfer function: $V_{\text{inst}}^2 = (V_{\text{measured}}^2 / V_{\text{expected}}^2)_{\text{CAL}}$ the calibrated visibility is estimated by: $V^2 = (V_{\text{measured}}^2)_{\text{SCI}} / V_{\text{inst}}^2$.
- phase closure transfer function: $CP_{\text{inst}} = (CP_{\text{measured}} - CP_{\text{expected}})_{\text{CAL}}$ the calibrated phase closure is estimated by: $CP = (CP_{\text{measured}}) - CP_{\text{inst}}$.

Other quantities can be calibrated, for example the chromatic phase dispersion. The chromatic phase dispersion is a function of the air path between each pair of telescopes. With many CAL at different DL stroke, one can compute a polynomial fit to the differential phase and extrapolate the polynomials coefficients as a function of air path difference.

All calibrator stars observation (DPR.CATG='CAL') are made public by ESO, so users can retrieve all calibrators taken in a given night in order to refine their estimation of the transfer function.

Sequence CAL-SCI-CAL should be used if absolute products will be used: this is the most common case. Some particular programmes only require differential interpretation: users should use the SCI-CAL sequence for this special programmes.

¹<http://www.eso.org/observing/etc/>

8 Bibliography

- [1] *Observing with the VLT Interferometer* Les Houches Eurowinter School, Feb. 3-8, 2002; Editors: Guy Perrin and Fabien Malbet; EAS publication Series, vol 6 (2003); EDP Sciences - Paris.
- [2] *The Very Large Telescope Interferometer - Challenges for the Future*, Astrophysics and Space Science vol 286, editors: Paulo J.V. Garcia, Andreas Glindemann, Thomas Henning, Fabien Malbet; November 2003, ISBN 1-4020-1518-6.
- [3] *Observing with the VLT Interferometer*, Wittkowski et al., March 2005, *The Messenger* 119, p14-17
- [4] Reference documents (templates, calibration plan, maintenance manual, science/technical operation plan), especially **VLT-MAN-ESO-15000-4552**, the **VLTI User Manual**.
- [5] *The VLTI real-time reflective memory data streaming and recording system*. R. Abuter, D. Popovic, E. Pozna, J. Sahlmann, and F. Eisenhauer. In Society of Photo-Optical Instrumentation Engineers (SPIE) Conference Series, volume 7013, July 2008.
- [6] *The fiber coupler and beam stabilization system of the GRAVITY interferometer* Pfuhl, O.; Haug, M.; Eisenhauer, F.; et al. 2014, **Proceedings of the SPIE**, Volume 9146, id. 914623 14 pp. (2014).
- [7] *First light for GRAVITY: Phase referencing optical interferometry for the VLTI* Gravity Collaboration; Abuter, R.; Accardo, M.; et al. 2017, **Astronomy & Astrophysics**, Volume 602, id. A94, 23 pp.
- [8] *First Light for GRAVITY: A New Era for Optical Interferometry* Gravity Collaboration 2017, **The Messenger**, vol. 170, p. 10-15.
- [9] *The GRAVITY fringe-tracker* Lacour, S.; Dembet, R.; Abuter, R. et al. 2019, **Astronomy & Astrophysics**, Volume 624, id. A99, 18 pp.
- [10] *The GRAVITY dual-field wide* GRAVITY+ Collaboration 2022, **Astronomy & Astrophysics**, Volume 665, id. A75, 15 pp.

9 Glossary

Constraint Set (CS): List of requirements for the conditions of the observation that is given inside an OB. OBs are only executed under this set of minimum conditions.

Dual-Field Mode: GRAVITY mode of operation when the FT reference and the SC target are distinct from each other. In this mode, the SC target may be fainter than the FT limiting magnitude, and astrometric phase information can be retrieved. The maximum separation between the two targets is 2'' with the UTs and 4'' with the ATs. In the dual-field wide mode the separation can be up to 30''.

fringe-tracker (FT): One sub-system central to the design of GRAVITY is its fringe-tracker, which analyses the fringes of a reference target in real time to estimate and correct for atmospheric and instrumental piston. This allows integrating longer on the science channel to obtain high signal-to-noise spectra at high resolution. The FT also provides for a natural phase reference in dual-field mode to detect fringes on a faint nearby object and to obtain differential astrometry between the FT and SC channels (not possible in dual-field wide mode).

Observation Block (OB): An Observation Block is the smallest schedulable entity for the VLT. It consists of a sequence of templates. Usually, a GRAVITY Observation Block includes one target acquisition and one exposure template. Especially for astrometric observations swapping the fringe-tracker and science targets, however, longer sequences are common.

Observation Description (OD): A sequence of templates used to specify the observing sequences within one or more OBs.

Proposal Preparation and Submission (Phase 1): The Phase 1 begins right after the Call for Proposals (CfP) and ends at the deadline for CfP. During this period the potential users are invited to prepare and submit scientific proposals. For more information, see:

<http://www.eso.org/sci/observing/phase1.html>

Observing Preparation (Phase 2): Once proposals have been approved by the ESO Observation Program Committee (OPC), users are notified and the Phase 2 begins. In this phase, users are requested to prepare their accepted proposals in the form of OBs using the p2 web application or Application Programming Interface (API). See:

<http://www.eso.org/sci/observing/phase2.html>

Service Mode (SM): In service mode (in contrast to “Visitor-Mode”), the observations are carried out by the ESO Paranal Science-Operation staff (PSO) alone. Observations can be done at any time during the period, depending on the CS given by the user. OBs are put into a queue schedule in OT which later sends OBs to the instrument.

Template: A template is a sequence of operations to be executed by the instrument. The observation software of an instrument dispatches commands written in templates not only to instrument modules that control its motors and the detector, but also to the telescopes and VLTI sub-systems.

Template signature file (TSF): File which contains template input parameters.

Visitor Mode (VM): The classic observation mode. The user is on-site to supervise his/her program execution, to directly analyse the data and to take real-time decisions if necessary.

10 Acronyms and Abbreviations

| | |
|----------|---|
| AO: | Adaptive Optics |
| AT: | Auxiliary Telescope (1.8m) |
| BCI: | GRAVITY Beam Combiner Instrument |
| CfP: | Call for Proposals |
| CIAO: | Coudé Infrared Adaptive Optics |
| CP: | Closure Phase |
| CS: | Constrain Set |
| DIT: | Detector Integration Time |
| DDL: | Differential Delay line |
| DL: | Delay Line |
| ERIS: | Enhanced Resolution Imager and Spectrograph (1 – 5 μm integral field unit) |
| ESO: | European Southern Observatory |
| ETC: | Exposure Time Calculator |
| FT: | Fringe-Tracker |
| FoV: | Field of View |
| GPAO: | GRAVITY+ Adaptive Optics |
| GTO: | Guaranteed Time Observations |
| IR: | Infra Red |
| LR: | Low Resolution |
| LST: | Local Sideral Time |
| MACAO: | Multiple Application Curvature Adaptive Optics |
| MATISSE: | Multi AperTure mid-Infrared SpectroScopic Experiment (3 – 13 μm beam combiner) |
| MR: | Medium Resolution |
| MIR: | Mid-InfraRed [5 – 20 μm] |
| NAOMI | New Adaptive Optics Module for Interferometry |
| NDIT: | Number of individual Detector Integrations |
| NIR: | Near-InfraRed [1 – 5 μm] |
| OD: | Observation Description |
| OB: | Observation Block |
| OT: | Observation Toolkit |
| OPC: | Observation Program Committee |
| OPD: | Optical Path Difference |
| OPL: | Optical Path Length |
| Phase 1: | Proposal Preparation and Submission |
| Phase 2: | Observing Preparation and Submission |
| PIONIER: | H-band 4-beam combiner instrument at the VLTI |
| QC: | Quality Control |
| SC: | Science Channel |
| SM: | Service Mode |
| SNR: | Signal-to-Noise Ratio |
| STS: | Star Separator (opto-mechanical system to separate the light of two astronomical objects) |
| TSF: | Template Signature File |
| UT: | Unit Telescope (8.2m) |
| VIMA: | VLTI Main Array (array of 4 UTs) |
| VISA: | VLTI Sub Array (array of ATs) |
| VLT: | Very Large Telescope |
| VLTI: | Very Large Telescope Interferometer |
| VM: | Visitor Mode |

–oOo–