

KAF- 0401LE

768 (H) x 512 (V) Pixel

**Enhanced Response
Full-Frame CCD Image Sensor
With Anti-Blooming Protection**

Performance Specification

Eastman Kodak Company

Image Sensor Solutions

Rochester, New York 14650-2010

**Revision No. 0
June 19, 2000**



TABLE OF CONTENTS

1.1 Features.....	3
1.2 Description.....	3
1.3 Image Acquisition.....	4
1.4 Charge Transport.....	4
1.5 Output Structure.....	4
1.6 Dark Reference Pixels.....	4
1.7 Dummy Pixels.....	4
2.1 Package Drawing.....	5
2.2 Pin Description.....	6
3.1 Absolute Maximum Ratings.....	7
3.2 DC Operating Conditions.....	8
3.3 AC Operating Conditions.....	9
3.4 AC Timing Conditions.....	9
4.1 Performance Specifications.....	11
4.2 Typical Performance Characteristics.....	12
4.3 Cosmetic Classification.....	13
5.1 Quality Assurance and Reliability.....	14
5.2 Ordering Information.....	14

APPENDICES

Part Number Availability.....	15
-------------------------------	----

FIGURES

Figure 1 Functional Block Diagram.....	3
Figure 2 Packaging Diagram.....	5
Figure 3 Packaging Pin Designations.....	6
Figure 4 Recommended Output Structure Load Diagram.....	8
Figure 5 Timing Diagrams.....	10



1.1 Features

- 393K Pixel Area CCD
- 768H x 512V (9 μm) Pixels
- Transparent Gate True Two Phase

Technology

(Enhanced Spectral Response)

- 6.91 mm H x 4.6 mm V Photosensitive Area
- 2-Phase Register Clocking
- 70% Fill Factor
- Antiblooming Protection
- Low Dark Current (<7pA/cm² @ 25°C)

1.2 Description

The KAF-0401LE is a high performance monochrome area CCD (charge-coupled device) image sensor with 768H x 512V photoactive pixels designed for a wide range of image sensing applications in the 0.4 nm to 1.0 nm wavelength band. Typical applications include military, scientific, and industrial imaging. A 67dB dynamic range is possible operating at room temperature.

The sensor is built with a true two-phase CCD technology employing a transparent gate.

This technology simplifies the support circuits that drive the sensor and reduces the dark current without compromising charge capacity. The transparent gate results in spectral response increased ten times at 400 nm, compared to a front side illuminated standard poly silicon gate technology. The sensitivity is increased 50% over the rest of the visible wavelengths.

Total chip size is 8.4 mm x 5.5 mm and is housed in a 24-pin, 0.805" wide DIL ceramic package with 0.1" pin spacing.

The sensor consists of 784 parallel (vertical) CCD shift registers each 520 elements long. These registers act as both the photosensitive elements and as the transport circuits that allow the image to be sequentially read out of the sensor. The elements of these registers are arranged into a 768 x 512 photosensitive array surrounded by a light shielded dark reference of 16 columns and 8 rows. The parallel (vertical) CCD registers transfer the image one line at a time into a single 796 element (horizontal) CCD shift register. The horizontal register transfers the charge to a single output amplifier. The output amplifier is a two-stage source follower that converts the photo generated charge to a voltage for each pixel.

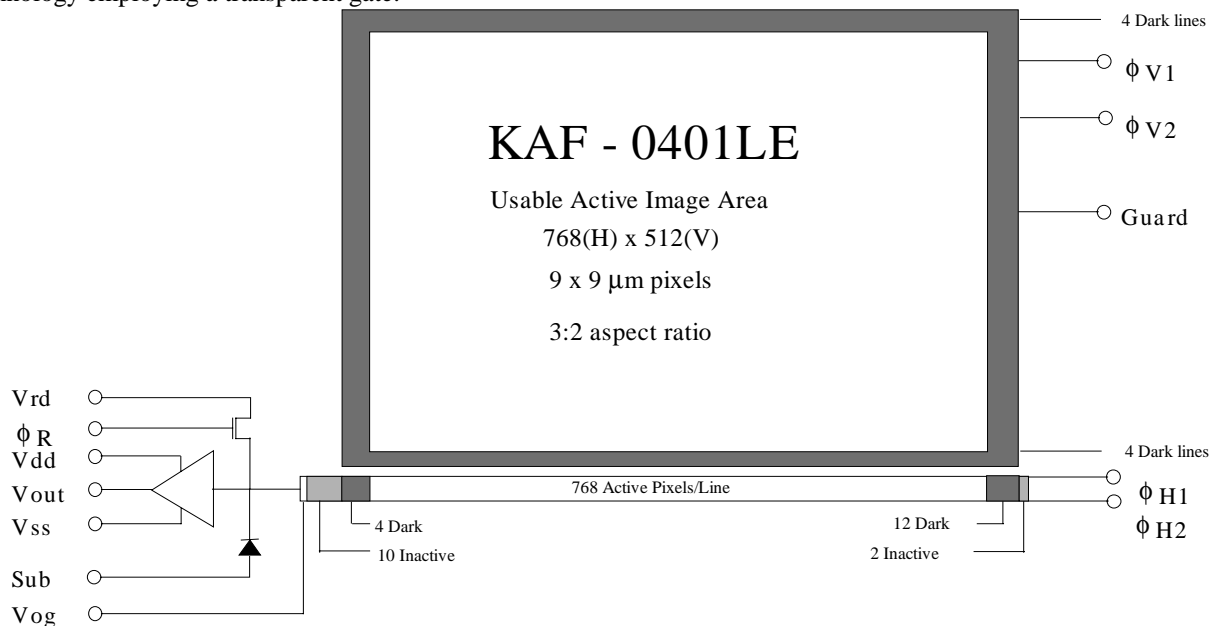

Figure 1 - Functional Block Diagram



Eastman Kodak Company – Image Sensor Solutions - Rochester, NY 14650-2010
 Phone (716) 722-4385 Fax (716) 477-4947
 Web: www.kodak.com/go/ccd E-mail: ccd@kodak.com

1.3 Image Acquisition

An electronic representation of an image is formed when incident photons falling on the sensor plane create electron-hole pairs within the sensor. These photon induced electrons are collected locally by the formation of potential wells at each photogate or pixel site. The number of electrons collected is linearly dependent on light level and exposure time and non-linearly dependent on wavelength. When the pixel's capacity is reached, excess electrons will spill into the lateral overflow drain (LOD) and drain off chip, thus isolating adjacent pixels from the excess signal. This is termed anti-blooming protection. During the integration period, the $\Phi V1$ and $\Phi V2$ register clocks are held at a constant (low) level.

See Figure 5. - Timing Diagrams.

The antiblooming capability is provided by a lateral overflow drain structure. This type of antiblooming design consumes thirty percent of the pixel area and reduces the saturation signal and quantum efficiency proportionately. However, it maintains the broad spectral response from 400 to 1000nm and good linear response up to saturation.

1.4 Charge Transport

Referring again to Figure 5 - Timing Diagrams, the integrated charge from each photogate is transported to the output using a two step process. Each line (row) of charge is first transported from the vertical CCD's to the horizontal CCD register using the $\Phi V1$ and $\Phi V2$ register clocks. The horizontal CCD is presented a new line on the falling edge of $\Phi V2$ while $\Phi H1$ is held high. The horizontal CCD's then transport each line, pixel by pixel, to the output structure by alternately clocking the $\Phi H1$ and $\Phi H2$ pins in a complementary fashion. On each falling edge of $\Phi H2$ a new charge packet is transferred onto a floating diffusion and sensed by the output amplifier

1.5 Output Structure

Charge presented to the floating diffusion (FD) is converted into a voltage and current amplified in order to drive off-chip loads. The resulting voltage change seen at the output is linearly related to the amount of charge placed on FD. Once the signal has been sampled by the system electronics, the reset gate (ΦR) is clocked to remove the signal and FD is reset to the potential applied by VRD. More signal at the floating diffusion reduces the voltage seen at the output pin. In order to activate the output structure, an off-chip load must be added to the Vout pin of the device - see Figure 4.

1.6 Dark Reference Pixels

Surrounding the peripheral of the device is a border of light shielded pixels. This includes 4 leading and 12 trailing pixels on every line excluding dummy pixels. There are also 4 full dark lines at the start of every frame and 4 full dark lines at the end of each frame. Under normal circumstances, these pixels do not respond to light. However, dark reference pixels in close proximity to an active pixel, or the outer bounds of the chip (including the first two lines out), can scavenge signal depending on light intensity and wavelength and therefore will not represent the true dark signal.

1.7 Dummy Pixels

Within the horizontal shift register are 10 leading and 2 trailing additional shift phases that are not associated with a column of pixels within the vertical register. These pixels contain only horizontal shift register dark current signal and do not respond to light. A few leading dummy pixels may scavenge false signal depending on operating conditions



2.1 Package Drawing

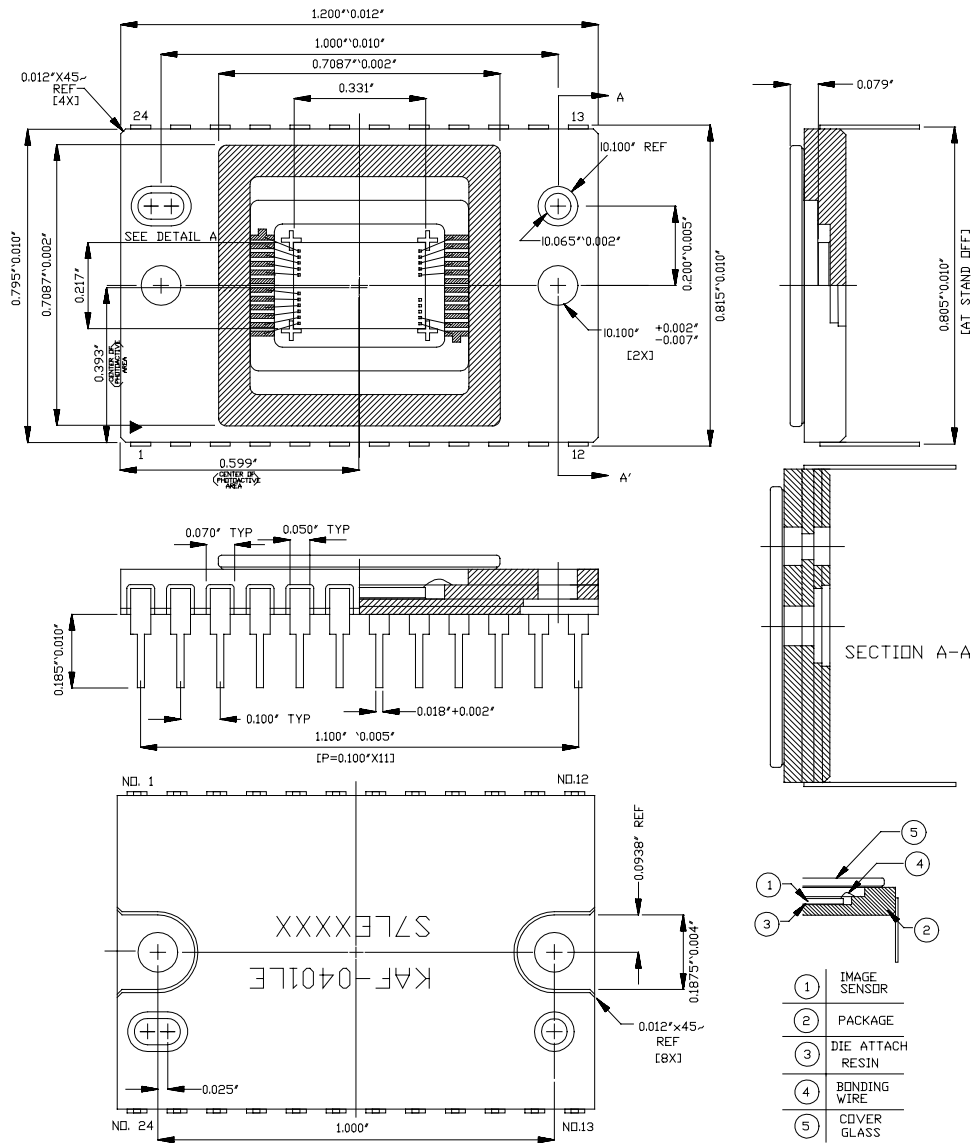

Figure 2 - Package Drawing



Eastman Kodak Company – Image Sensor Solutions - Rochester, NY 14650-2010

Phone (716) 722-4385

Fax (716) 477-4947

Web: www.kodak.com/go/ccd

E-mail: ccd@kodak.com

2.2 Pin Description

Pin	Symbol	Description	Pin	Symbol	Description
1	VOG	Output Gate	13	N/C	No connection (open pin)
2	VOUT	Video Output	11, 14	VSUB	Substrate (Ground)
3	VDD	Amplifier Supply	15, 16, 21, 22	ϕV_1	Vertical CCD Clock - Phase 1
4	VRD	Reset Drain	17, 18, 19, 20	ϕV_2	Vertical CCD Clock - Phase 2
5	ϕR	Reset Clock	23	Guard	Guard Ring
6	VSS	Amplifier Supply Return	24	N/C	No Connection (open pin)
7	ϕH_1	Horizontal CCD Clock - Phase 1			
8	ϕH_2	Horizontal CCD Clock - Phase 2			
9, 10, 12	N/C	No connection (open pin)			

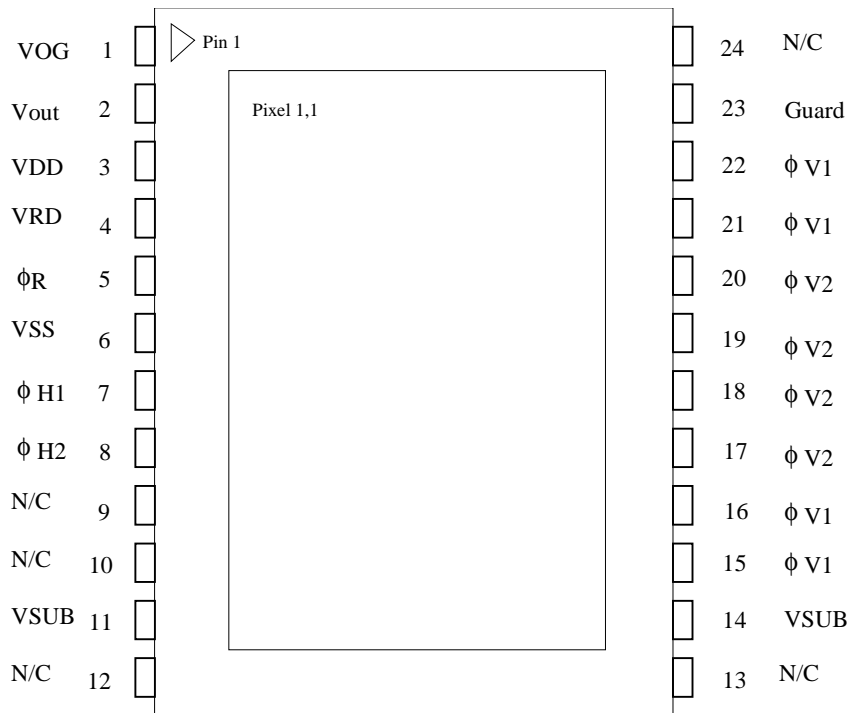

Figure 3 - Packaging Pin Designations



3.1 Absolute Maximum Ratings

Description	Symbol	Min.	Max.	Units	Notes
Diode Pin Voltages	Vdiode	0	20	V	1, 2
Gate Pin Voltages - Type 1	Vgate1	-16	16	V	1, 3
Gate Pin Voltages - Type 2	Vgate2	0	16	V	1, 4
Inter-Gate Voltages	Vg-g		16	V	5
Output Bias Current	Iout		-10	mA	6
Output Load Capacitance	Cload		15	pF	6
Storage Temperature	T		100	°C	
Humidity	RH	5	90	%	7

Notes:

1. Referenced to pin VSUB.
2. Includes pins: VRD, VDD, VSS, VOUT.
3. Includes pins: $\phi V1$, $\phi V2$, $\phi H1$, $\phi H2$.
4. Includes pins: ϕR , VOG.
5. Voltage difference between overlapping gates. Includes: $\phi V1$ to $\phi V2$, $\phi H1$ to $\phi H2$, $\phi V2$ to $\phi H1$, $\phi H2$ to VOG.
6. Avoid shorting output pins to ground or any low impedance source during operation.
7. T=25°C. Excessive humidity will degrade MTTF.

CAUTION: This device contains limited protection against Electrostatic Discharge (ESD). Devices should be handled in accordance with strict ESD control procedures for Class 1 devices.



3.2 DC Operating Conditions

Description	Symbol	Min.	Nom.	Max.	Units	Max DC Current (mA)	Notes
Reset Drain	VRD	10.5	11	11.5	V	0.01	
Output Amplifier Return	VSS	1.5	2.0	2.5	V	-0.5	
Output Amplifier Supply	VDD	14.5	15	15.5	V	Iout	
Substrate	VSUB	0	0	0	V	0.01	
Output Gate	VOG	3.75	4	5	V	0.01	
Guard Ring	Guard	8.0	9.0	12.0	V	0.01	
Video Output Current	Iout		-5	-10	mA	-	1

Notes:

1. An output load sink must be applied to Vout to activate output amplifier - see Figure below.

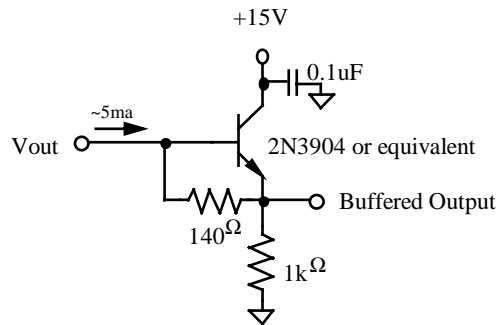

Figure 4 - Recommended Output Structure Load Diagram



3.3 AC Operating Condition

Description	Symbol	Level	Min.	Nom.	Max.	Units	Effective Capacitance
Vertical CCD Clock - Phase 1	$\phi V1$	Low	-10.5	-10.0	-9.5	V	6 nF (all $\phi V1$ pins)
		High	0	0.5	1.0	V	
Vertical CCD Clock - Phase 2	$\phi V2$	Low	-10.5	-10.0	-9.5	V	6 nF (all $\phi V2$ pins)
		High	0	0.5	1.0	V	
Horizontal CCD Clock - Phase 1	$\phi H1$	Low	-5.0	-4.0	-3.5	V	50 pF
		High	5.0	6.0	6.5	V	
Horizontal CCD Clock - Phase 2	$\phi H2$	Low	-5.0	-4.0	-3.5	V	50 pF
		High	5.0	6.0	6.5	V	
Reset Clock	ϕR	Low	-4.0	-3.0	-2.0	V	5pF
		High	3.5	4.0	5.0	V	

Notes:

1. All pins draw less than 10uA DC current.
2. Capacitance values relative to VSUB.

3.4 AC Timing Conditions

Description	Symbol	Min.	Nom.	Max.	Units	Notes
$\phi H1, \phi H2$ Clock Frequency	f_H		10	15	MHz	1, 2, 3
$\phi V1, \phi V2$ Clock Frequency	f_V		100	125	kHz	1, 2, 3
Pixel Period (1 Count)	t_e	67	100		ns	
$\phi H1, \phi H2$ Setup Time	$t_{\phi HS}$	0.5	1		us	
$\phi V1, \phi V2$ Clock Pulse Width	$t_{\phi V}$	4	5		us	2
Reset Clock Pulse Width	$t_{\phi R}$	10	20		ns	4
Readout Time	$t_{readout}$	34	50		ms	5
Integration Time	t_{int}					6
Line Time	t_{line}	65.8	95.6		us	7

Notes:

1. 50% duty cycle values.
2. CTE may degrade above the nominal frequency.
3. Rise and fall times (10/90% levels) should be limited to 5-10% of clock period. Cross-over of register clocks should be between 40-60% of amplitude.
4. f_R should be clocked continuously.
5. $t_{readout} = (1032 * t_{line})$
6. Integration time is user specified. Longer integration times will degrade noise performance due to dark signal fixed pattern and shot noise.
7. $t_{line} = (3 * t_{\phi V}) + t_{\phi HS} + (1564 * t_e) + t_e$



4.1 Performance Specifications

All values measured at 25°C, and nominal operating conditions. These parameters exclude defective pixels.

Description	Symbol	Min.	Nom.	Max.	Units	Notes
Saturation Signal						
Vertical CCD capacity	Nsat	45000	50000	65000	electrons / pixel	1
Horizontal CCD capacity		170000	200000	240000		
Output Node capacity		190000	220000	240000		
Red Quantum Efficiency ($\lambda=650\text{nm}$)	Rr		42		%	
Green Quantum Efficiency ($\lambda=550\text{nm}$)	Rg		35		%	
Blue Quantum Efficiency ($\lambda=450\text{nm}$)	Rb		20		%	
Blue Quantum Efficiency ($\lambda=400\text{nm}$)	Rb 400		16		%	
Photoresponse Non-Linearity	PRNL		1	2	%	2
Photoresponse Non-Uniformity	PRNU		1	3	%	3
Dark Signal	Jdark		15	35	electrons / pixel / sec	4
			2.1	7	pA/cm ²	
Dark Signal Doubling Temperature		5	6.3	7.5	°C	
Dark Signal Non-Uniformity	DSNU		25	50	electrons / pixel / sec	5
Dynamic Range	DR	67	70		dB	6
Charge Transfer Efficiency	CTE	0.99997	0.99999			
Output Amplifier DC Offset	V _{odc}	9.5	10.5	11.5	V	7
Output Amplifier Bandwidth	f _{-3dB}		45		Mhz	8
Output Amplifier Sensitivity	V _{out} /N _{e~}	9	10	11	uV/e~	
Output Amplifier output Impedance	Z _{out}	175	200	250	Ohms	
Noise Floor	n _{e~}		15	20	electrons	9
Antiblooming Protection	V _{ab}	128			Saturation exposure	10

Notes:

- For pixel binning applications, electron capacity up to 330000 can be achieved with modified CCD inputs. Each sensor may have to be optimized individually for these applications. Some performance parameters may be compromised to achieve the largest signals.
- Worst case deviation from straight line fit, between 1% and 90% of V_{sat}.
- One Sigma deviation of a 128x128 sample when CCD illuminated uniformly.
- Average of all pixels with no illumination at 25 °C..
- Average dark signal of any of 6 x 4 blocks within the sensor. (each block is 128 x 128 pixels)
- 20log (Nsat / n_{e~}) at nominal operating frequency and 25 °C.
- Video level offset with respect to ground
- Last output amplifier stage only. Assumes 10pF off-chip load..
- Output noise at 25 °C , nominal operating frequency, and tint = 0.
- Number of times above the V_{sat} illumination level required to cause 50% distortion in a test pattern consisting of a bright circular region approximately 1/10 the size of the image sensor. In most systems a 128x optical overload will cause flare from reflections that mask the performance of the image sensor.



4.2 Typical Performance Characteristics

Spectral Response

KAF-0401LE

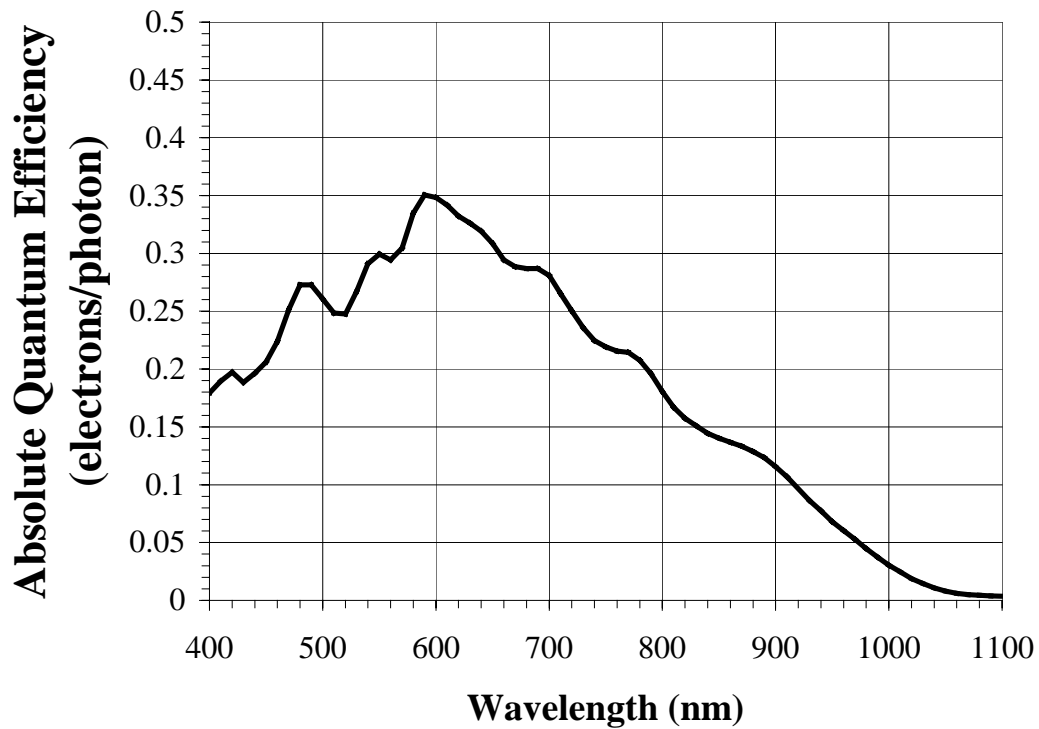

Eastman Kodak Company – Image Sensor Solutions - Rochester, NY 14650-2010

Phone (716) 722-4385

Fax (716) 477-4947

Web: www.kodak.com/go/ccd

E-mail: ccd@kodak.com

4.3 Cosmetic Classification

Defect tests performed at T=25°C

Class	Point Defects Total	Cluster Defects Total	Column Defects Total
C0	0	0	0
C1	≤5	0	0
C2	≤10	≤4	0

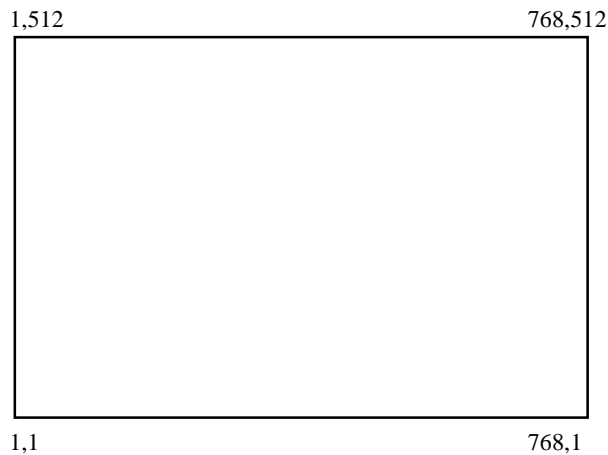

- Point Defect DARK: A pixel which deviates by more than 6% from neighboring pixels when illuminated to 70% of saturation, OR BRIGHT: A Pixel with dark current > 3000 e/pixel/sec at 25C.
- Cluster Defect A grouping of not more than 5 adjacent point defects
- Column Defect A grouping of >5 contiguous point defects along a single column, OR
A column containing a pixel with dark current > 6,000e/pixel/sec, OR A column that does not meet the minimum vertical CCD charge capacity, OR
A column which loses more than 250 e under 2Ke illumination.
- Neighboring pixels The surrounding 128 x 128 pixels or ±64 columns/rows.
- Defect Separation Column and cluster defects are separated by no less than two (2) pixels in any direction (excluding single pixel defects).
- Defect Region Exclusion Defect region excludes the outer two (2) rows and columns at each side/end of the sensor.



5.1 Quality Assurance and Reliability

- 5.1.1 Quality Strategy: All devices will conform to the specifications stated in this document. This is accomplished through a combination of statistical process control and inspection at key points of the production process.
- 5.1.2 Replacement: All devices are warranted against failure in accordance with the terms of Terms of Sale.
- 5.1.3 Cleanliness: Devices are shipped free of contamination, scratches, etc. that would cause a visible defect.
- 5.1.4 ESD Precautions: Devices are shipped in a static-safe container and should only be handled at static-safe work stations.
- 5.1.5 Reliability: Information concerning the quality assurance and reliability testing procedures and results are available from the Image Sensor Solutions and can be supplied upon request.
- 5.1.6 Test Data Retention: Devices have an identifying number of traceable to a test data file. Test data is kept for a period of 2 years after date of shipment.

5.2 Ordering Information

See Appendix 1 for available part numbers

Address all inquiries and purchase orders to:

Image Sensor Solutions
Eastman Kodak Company
Rochester, New York 14650-2010
Phone: (716) 722-4385
Fax: (716) 477-4947
E-mail: ccd@kodak.com
Web: www.kodak.com/go/ccd

Eastman Kodak reserves the right to change any information contained herein without notice. All information furnished by Eastman Kodak is believed to be accurate.

WARNING: LIFE SUPPORT APPLICATIONS POLICY

Eastman Kodak image sensors are not authorized for and should not be used within Life Support Systems without the specific written consent of the Eastman Kodak Company. Product warranty is limited to replacement of defective components and does not cover injury or property or other consequential damages.



Eastman Kodak Company – Image Sensor Solutions - Rochester, NY 14650-2010
Phone (716) 722-4385 Fax (716) 477-4947
Web: www.kodak.com/go/ccd E-mail: ccd@kodak.com

Appendix 1

Part Number Availability

Note: This appendix may be updated independently of the performance specification.
Contact Eastman Kodak for the latest revision

Device Name	Available Part Numbers	Features
KAF-0401LE	2H4501	Clear Sealed Cover Glass, Class 0
KAF-0401LE	2H4502	Clear Sealed Cover Glass , Class 1
KAF-0401LE	2H4503	Clear Sealed Cover Glass, Class 2
KAF-0401LE	2H4504	Clear Sealed Cover Glass , Engineering Grade
KAF-0401LE	2H4505	Clear Sealed Cover Glass, Class Mechanical Grade
KAF-0401LE	2H4518	Clear Snap-on Plastic Cover , Class 0
KAF-0401LE	2H4519	Clear Snap-on Plastic Cover , Class 1
KAF-0401LE	2H4498	Clear Snap-on Plastic Taped Cover , Class 2
KAF-0401LE	2H4499	Clear Snap-on Plastic Cover , Engineering Grade
KAF-0401LE	2H4500	Clear Snap-on Plastic Cover, Mechanical Grade



Eastman Kodak Company – Image Sensor Solutions - Rochester, NY 14650-2010
 Phone (716) 722-4385 Fax (716) 477-4947
 Web: www.kodak.com/go/ccd E-mail: ccd@kodak.com